

Save This Manual
For Future Reference

SEARS

**Operators
Manual**

**MODEL NO.
113.197210**

10" ELECTRONIC
RADIAL SAW WITH
23" CABINET AND
1 DOOR

or

113.197250

10" ELECTRONIC
RADIAL SAW WITH
LEG SET

Serial
Number _____
Model and serial numbers
may be found at the rear of
the base.
You should record both
model and serial number in
a safe place for future use.

**FOR YOUR
SAFETY:**

**READ ALL
INSTRUCTIONS
CAREFULLY**

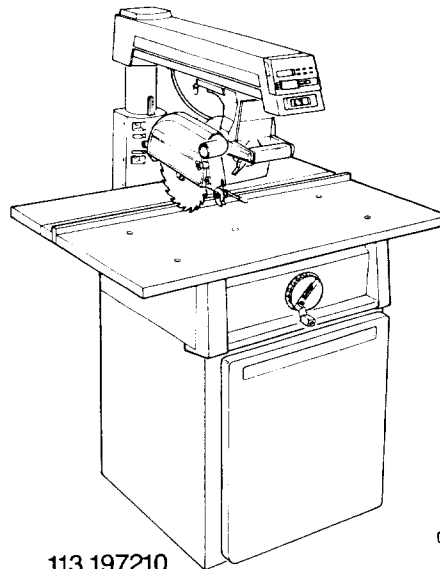

113.197210

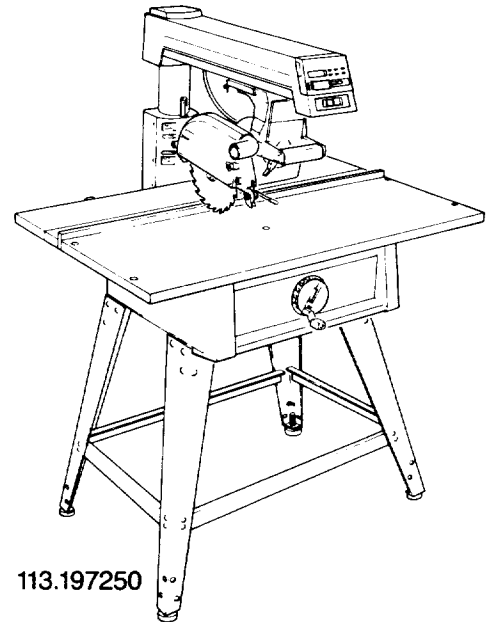

113.197250



CRAFTSMAN

**10-INCH ELECTRONIC
RADIAL SAW**

- Assembly
- Operating
- Repair parts

Sold by SEARS, ROEBUCK AND CO., Chicago, IL. 60684 U.S.A.

FULL ONE YEAR WARRANTY ON CRAFTSMAN RADIAL SAW

If within one year from the date of purchase, this Craftsman Radial Saw fails due to a defect in material or workmanship, Sears will repair it, free of charge.

WARRANTY SERVICE IS AVAILABLE BY SIMPLY CONTACTING THE NEAREST SEARS SERVICE CENTER/DEPARTMENT THROUGHOUT THE UNITED STATES.

This warranty applies only while this product is used in the United States.

This warranty gives you specific legal rights and you may also have other rights which vary from state to state.

SEARS, ROEBUCK AND CO., DEPT. 698/731A Sears Tower, Chicago, IL 60684

Table of Contents

Section Title	Page Numbers
Safety Information	3-6
Putting Your Saw Together	7-19
Location and Function of Controls	20-23
Alignment of Blade	24-39
Digital Display	40-45
Electrical Connections	46-47
Crosscutting	48-54
Ripping	55-63
Cutting Accessories	64-67
Recommended Accessories	68
Lower Blade Guard Safety Information	69
Glossary	70
Helpful Hints	71-73
Maintaining Your Saw	74-79
Trouble Shooting	80-85
Parts Lists	86-101

Safety Information

The operator's manual contains safety information, instructions and signs for your protection against serious injuries, including:

Loss of fingers, hand, arm or leg from contact with the saw blade.

Eye injuries, including being blinded from being hit by a thrown workpiece, workpiece chips or pieces of the saw blade.

Impact injuries, including broken bones and internal organ damage, from being hit by a thrown workpiece, workpiece chips or pieces of the saw blade.

Shock, electrocution, or burn injuries from contact with wires, motor or other saw parts.

Safety Symbol and Signal Words

The safety information in this manual is highlighted by the following safety alert symbol.



Fig. 1 Safety Alert Symbol

The following signal words are used to indicate the level of risk.

⚠ DANGER: Means that if the safety information is not followed, someone **will** be seriously injured or killed.

⚠ WARNING: Means that if the safety information is not followed someone **could** be seriously injured or killed.

⚠ CAUTION: Means that if the safety information is not followed someone **may** be injured.

All of the safety information **and cutting steps** are critical to the safe operation of the radial arm saw.

Major Hazards

1. Workpiece Kickback

Kickback is an uncontrolled grabbing and throwing of the workpiece during ripping. If kickback occurs, the workpiece can hit you hard enough to cause broken bones, internal organ injury or death. To reduce or prevent kickback, read and follow the safety information in the Ripping section of the manual.

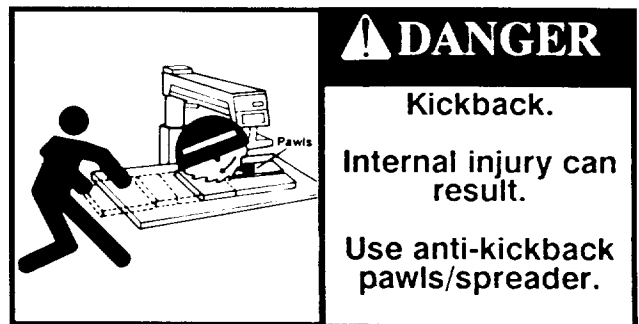

Fig. 2 Kickback Safety Sign

2. Kickback Followed by Blade Contact

Kickback followed by blade contact can happen when the saw blade is pinched or bound by the workpiece during ripping. Kickback can happen if you reach around the blade to the end **with** the anti-kickback pawls, (out-feed end), and try to hold-down or pull the workpiece through to complete the cut. Your fingers, hand, or arm can be cut off by the blade if the workpiece kicks back.



Fig. 3 Blade Contact Safety Sign

3. Wrong Way Feed

Wrong way feed is feeding the workpiece into the end of the saw **with** the anti-kickback pawls. The workpiece can be grabbed by the blade and pull your hands into the blade before you can let go or pull back. Fingers, hand or arm can be cut off.

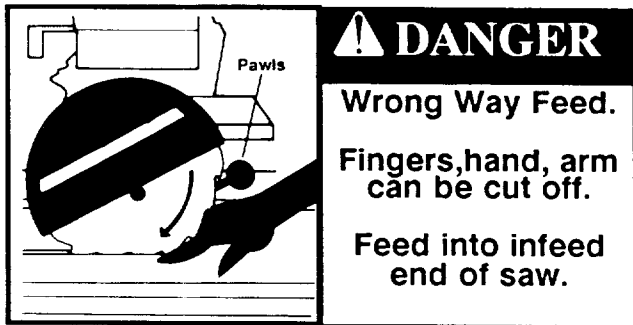

Fig. 4 Wrong Way Feed Safety Sign

If a workpiece is fed into the end of the saw **with** the anti-kickback pawls, it can take off like a missile. Anyone hit by the workpiece can be killed. Feed the workpiece into the infeed end of the saw blade, the end that does **not** have the anti-kickback pawls.

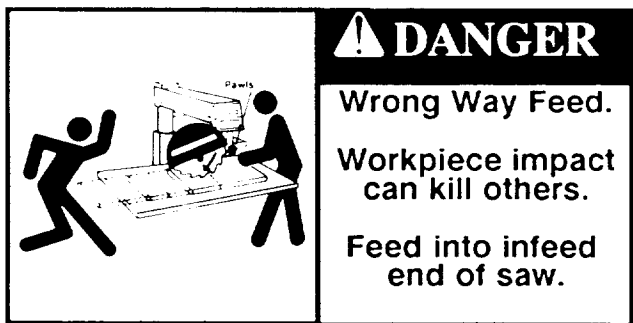

Fig. 5 Wrong Way Feed Safety Sign

4. Thrown Workpiece Chips and Blade Pieces

The saw can throw the workpiece, workpiece chips or pieces of the blade violently. You can be blinded. Wear safety goggles labeled "ANSI Z87.1" on the package.



Fig. 6 Safety Goggles Safety Sign

⚠ DANGER: Follow the 8 steps listed below to reduce or eliminate the risk of being injured when using the radial arm saw. Failure to do so can result in a life threatening injury or death.

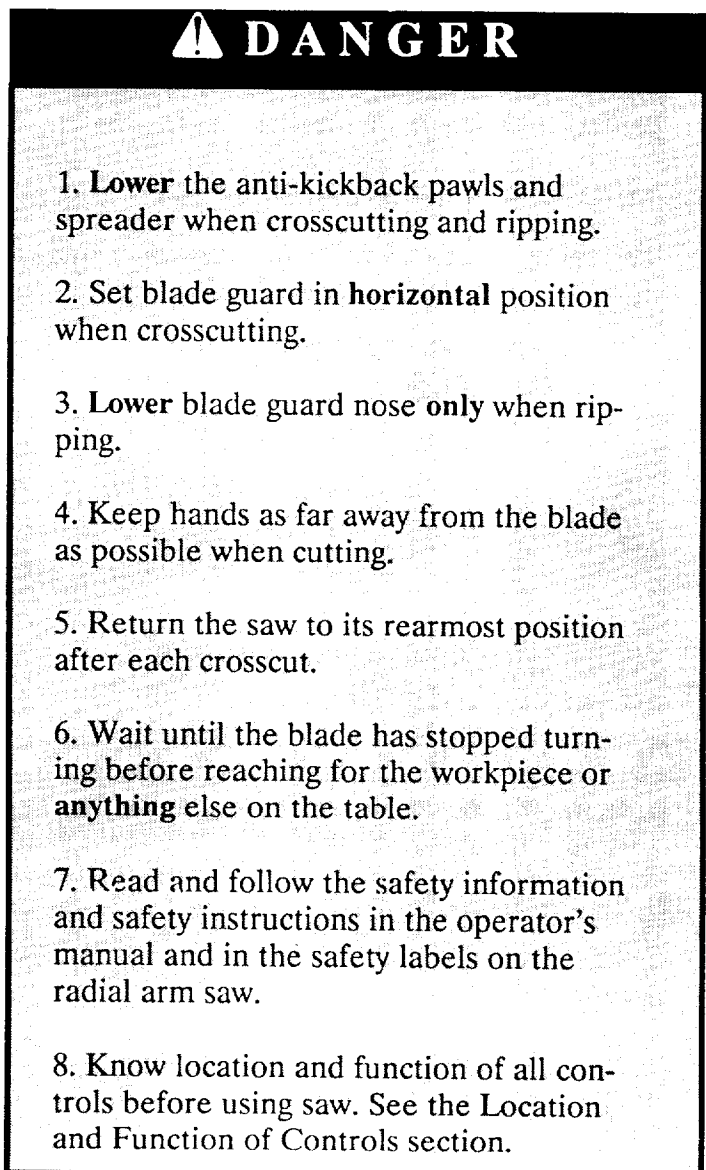

Personal Safety

1. Wear safety goggles labeled "ANSI Z87.1" on the package. Do not wear regular glasses, they are not safety glasses.
2. Wear snug fitting clothes, short sleeve shirts and nonslip footwear. Cover up or tie long hair. Do not wear loose, baggy clothes, gloves, neckties, rings, watches or any other jewelry.
3. Wear a dust mask, with your safety goggles, if cutting operation is dusty.
4. Wear hearing protectors, ear plugs or muffs, if you use the saw daily.
5. Keep good footing and balance. Don't over-reach.

Work Area Safety

1. Keep children, pets and visitors out of the work area.
2. Make the work area child proof. Remove the yellow key from the red switch and place it out of reach and sight. Lock work area.
3. Keep floors dry and free from sawdust, wax or other slippery materials.
4. Keep work area clean, uncluttered and well lighted.
5. Use the saw in a dry area. Do not use in wet or damp area. Do not use outside.
6. Clear the table of all objects (adjusting wrenches, tools, scraps of wood etc.) except the workpiece to be cut, fixtures or clamps before turning the saw on.
7. Do not do layout, assembly or setup work on the table while the blade is turning.
8. Store items away from the saw. Do not climb on the saw to reach items. Do not stand on the table; the saw can tip over.

Saw Safety

1. Keep guards and anti-kickback pawls in place and in working order.
2. Check for broken or damaged parts before using saw. A damaged guard or other saw part should be checked for alignment, binding, breakage and correct mounting to make sure they are working properly. Repair or replace damaged guards or other saw parts.
3. Unplug saw before doing maintenance, making adjustments, and changing blades and accessories.
4. Use clamps or vice to hold workpiece when practical. It's safer than using your hands and frees them to operate the saw.
5. Do not force the saw, saw blade or accessories to do jobs they are not designed to do.
6. Make sure the yellow key is removed and the red switch is in the off position before plugging in the power cord.
7. Cut only wood, woodlike or plastic materials. Do not cut metal materials.
8. Secure the saw to floor, wall, bench or table if it slides, tips or walks during use.
9. Feed the workpiece against the direction of rotation of the blade when ripping.
10. Turn the saw off before leaving work area. Do not leave the saw until the blade has stopped.
11. Lock the rip and miter locks before moving the saw from one location to another.
12. Turn the saw off and remove yellow key if the blade jams. Do not try to free a jammed workpiece with the saw on.
13. Turn the saw off if it vibrates excessively or makes an unfamiliar noise. Correct any problems before restarting saw.

14. Rip workpieces that are longer than the diameter of the blade being used. Do not rip a workpiece that is shorter than the diameter of the blade being used.

15. Cut only one workpiece at a time. Do not cut stacked workpieces or lay them edge to edge for cutting.

Workpiece Support Safety

1. Use additional supports for workpieces which extend beyond the saw table. Large workpieces can shift, twist, rise from table or fall after they are cut.

2. Helpers can be hit by a thrown workpiece, workpiece chips or pieces of the blade. Use table extensions or other supports. Do not use helpers.

3. Helpers can cause the workpiece to kick-back. Do not use other people to support or assist in feeding or pulling the workpiece. Use table extensions.

4. When table extensions over 24 inches wide are added to either side of the saw, make sure you either bolt the saw to the floor or support the outer end of the extension from the floor with sturdy legs or an outrigger.

5. Use Only Recommended Accessories

Follow the instructions that come with the accessories.

Consult the owner's manual for recommended accessories.

The use of improper accessories may cause risk of injury to persons.

Blade Safety

1. Use blades marked for 3450 rpm or higher.

2. Do not use blades larger than 10 inches in diameter.

3. Keep blade sharp and clean.

4. Do not cycle motor switch on and off rapidly; the blade can loosen.

5. Do not overtighten the blade; the blade collar can be warped.

Safety Labels on the Radial Arm Saw

The following labels are on your radial arm saw. Locate, read and follow the safety instructions and information contained in these labels.

1. Wrong way feed label located on the out-feed end of the blade guard.

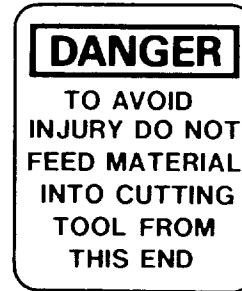

Fig. 7 Wrong Way Feed Label

2. Safety instruction label located on the front of the saw near the handwheel.

DANGER

FOR YOUR OWN SAFETY:

1. Read and understand owner's manual before operating machine.
2. Wear safety goggles complying with ANSI Z87.1.
3. Keep hands out of path of saw blade.
4. Never reach around the saw blade.
5. Never perform any operation "FREEHAND."
6. Return carriage to the full rear position after each cross-cut type operation.
7. Shut off power and allow saw blade to stop before adjusting or servicing.

Fig. 8 Safety Instruction Label

3. Ripping safety label located on the motor.

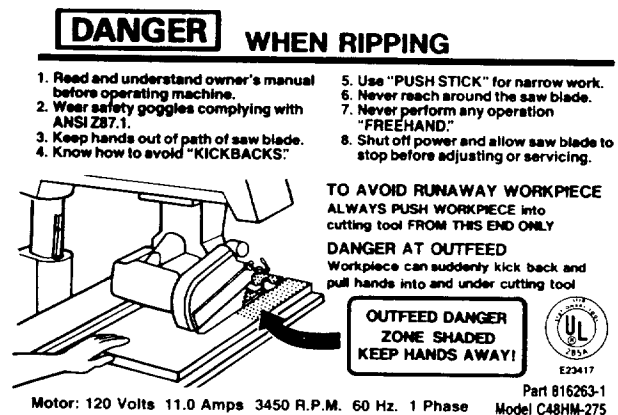

Fig. 9 Ripping Safety Label

Putting Your Saw Together

Your radial arm saw is easy to put together, however it will take time. Ask a friend to help, and follow these assembly instructions. It is important for your safety, and for the quality of your cuts, that the saw be put together with care.

This manual was written for two different models of the radial arm saw: model 113.197210 with cabinet and door, and model 113.197250 with leg set.

The following assembly sections should be followed for both models:

- Unpacking / Set up
- Information
- Attaching Handwheel
- Mounting Motor
- Mounting Saw
- Attaching Trim Ledge and Trim Caps
- Mounting Table Locks
- Mounting the Front Table

All other sections are labelled with the correct model number. Follow **ONLY** instructions that are meant for your model saw. Both models work in the same way once they are put together.

⚠ WARNING: Plugging the saw in during assembly can result in electrical shock or your fingers, hand, or arm being cut off from blade contact. Do not plug in the saw at any time during assembly. The saw should only be plugged in when it is to be used.

Unpacking/Set up

Both Models

1. As you unpack, try to keep the contents of each of the smaller bags together and separate from the others. This will help you identify and locate the parts you need during assembly.

The following parts are included with model 113.197210:

A Basic Saw Assembly	1
B Rear Table	1
C Table Spacer	1
D Rip Fence	1
E Front Table	1
F Operators Manual	1
G Loose Parts Bag	5
H Table Mounting, Channel	2
I Trim Cap, R.H.	1
J Trim Cap, L.H.	1
K 23" Cabinet with Door	1

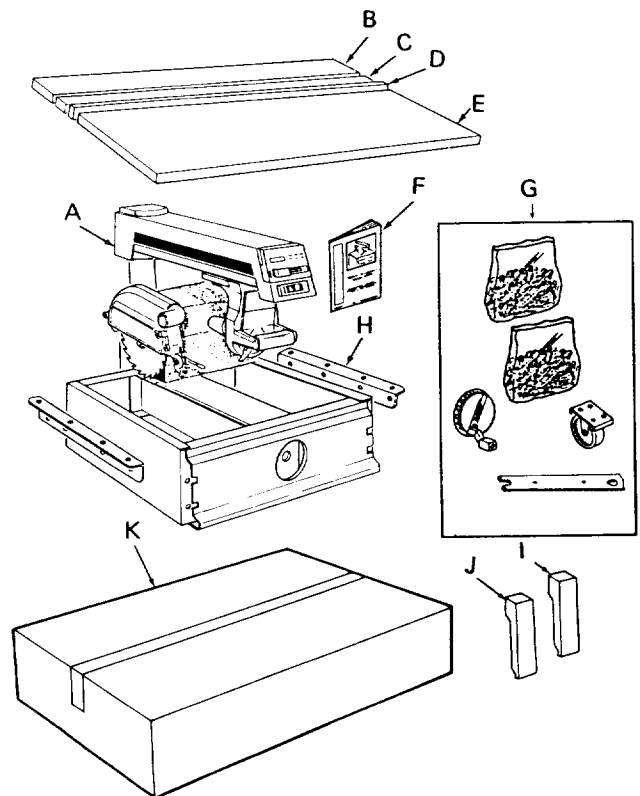

Fig. 10 - Parts for Model 113.197210

The following parts are included with model 113.197250:

A	Basic Saw Assembly	1
B	Rear Table	1
C	Table Spacer	1
D	Rip Fence	1
E	Front Table	1
F	Operators Manual	1
G	Loose Parts Bag	5
H	Table Mounting Channel	2
I	Trim Cap, R.H.	1
J	Trim Cap, L.H.	1
K	Leg	4
L	Lower Stiffener	4
M	"U"-Channel	1

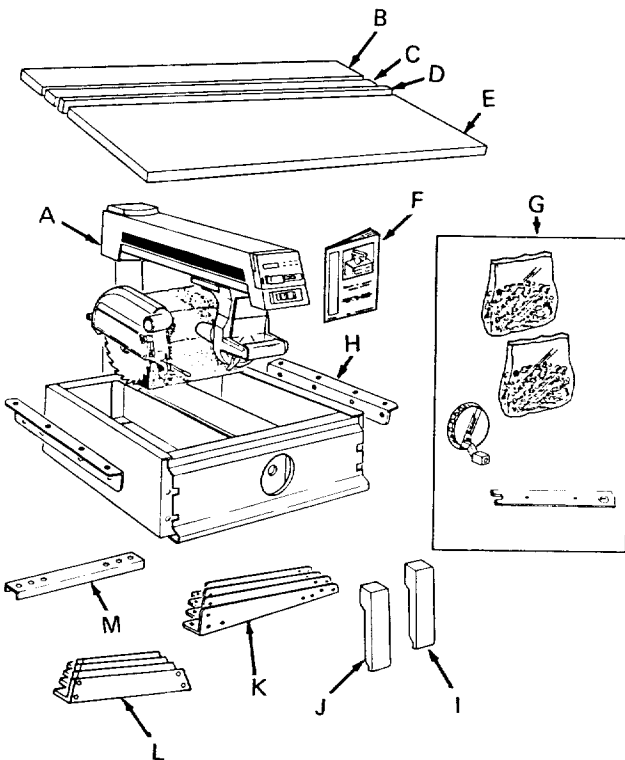

Fig. 11 - Parts for Model 113.197250

2. Identify the large parts of your saw before beginning each section. Your task will be easier if you are familiar with these parts.

3. Identify the tools required for assembly. Make sure that you have all of the tools you will need. (Figure 12)

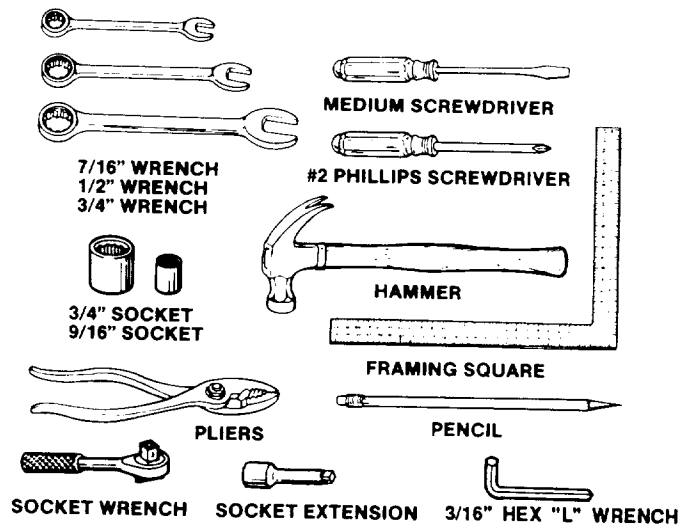
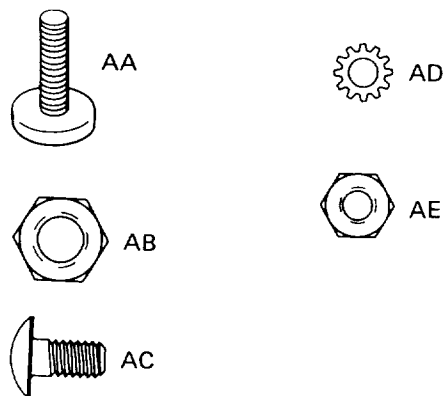

Fig. 12 - Tools Required

4. Open the loose parts bags, and sort the contents into piles on the floor or table. This will make it easier for you to find the part(s) you need during assembly.

The following loose parts are included with model 113.197210:

AA	Leveling Foot	4
AB	Hex Jam Nut 3/8-16	8
AC	Truss Hd. Bolt 1/4-20 x 1/2	42
AD	External Lockwasher 1/4	42
AE	Hex Nut 1/4-20	42



AF	Hex Hd. Screw 5/16-18 x 3/4	4
AG	Washer 11/32 x 7/8 x 1/16	4
AH	Lockwasher 5/16	4
AI	Hex Nut 5/16-18	4
AJ	Pan Hd. Screw 1/4-20 x 1	4
AK	Washer 17/64 x 5/8 x 1/32	5
AL	Lockwasher 1/4	4
AM	Hex Nut 1/4-20	4
AN	Table Clamp	2
AO	Tee Nut	1
AP	Cup Point Set Screw 1/4-20 x 7/8	1
AQ	Pan Hd. Screw Ty T 1/4-20 x 1-3/4	1
AR	"U" Clip 1/4-20	1
AS	Pan Hd. Screw #6-10 x 1/2	2
AT	Pan Hd. Screw Ty "T" 6-32 x 3/8	2
AU	Pan Hd. Screw #10-10 x 1/2	4
AV	Magnetic Catch	1
AW	Door Hinge	2
AX	Yoke Plug	1
AY	Switch Key	1
AZ	Battery	1
BA	Pan Hd. Screw 10-32 x 1/2	1
BB	Battery Cover	1
BC	External Lockwasher #10	1
BD	Handwheel	1
BE	Arbor Wrenches	2
BF	Casters	2
BG	Hex Bushing	1

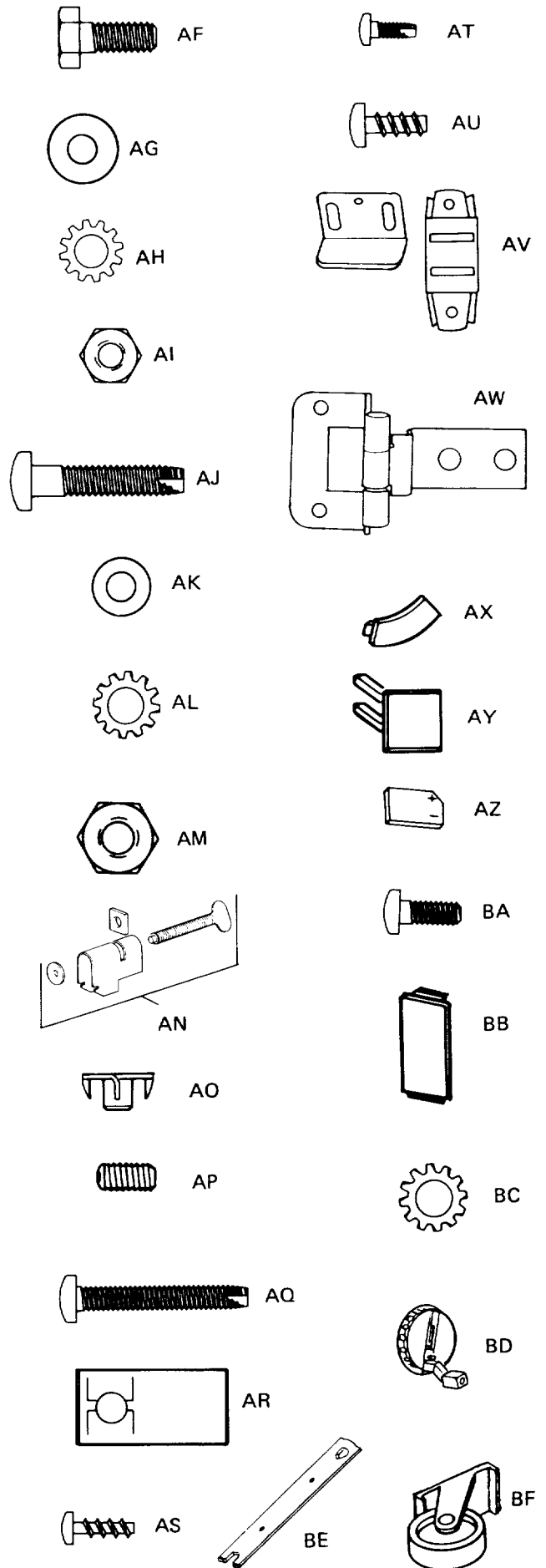

BG

The following loose parts are included with model 113.197250:

BG	Leveling Feet	4
BH	Hex Nuts 3/8-16	8
BJ	Truss Head Bolts 1/4-20 x 1/2	32
BK	Lockwashers 1/4	32
BL	Hex Nuts 1/4-20	32
BM	Hex Hd. Screw 5/16-18 x 3/4	4
BN	Washer 11/32 x 7/8 x 1/16	4
BO	Lockwasher 5/16	4
BP	Hex Nut 5/16-18	4
BQ	Pan Hd. Screw 1/4-20 x 1	4
BR	Washer 17/64 x 5/8 x 1/32	5
BS	Lockwasher 1/4	4
BT	Hex Nut 1/4-20	4
BU	Table Clamp	2
BV	Tee Nut	1
BW	Cup Point Set Screw 1/4-20 x 7/8	1
BX	Pan Hd. Screw Ty T 1/4-20 x 1-3/4	1
BY	"U" Clip 1/4-20	1
BZ	Yoke Plug	1
CA	Switch Key	1
CB	Battery	1
CC	Pan Hd. Screw 10-32 x 1/2	1
CD	External Lockwasher #10	1
CE	Battery Cover	1
CF	Handwheel	1
CG	Arbor Wrench	2
CH	Bracket, Leg	4
CI	Hex Bushing	1

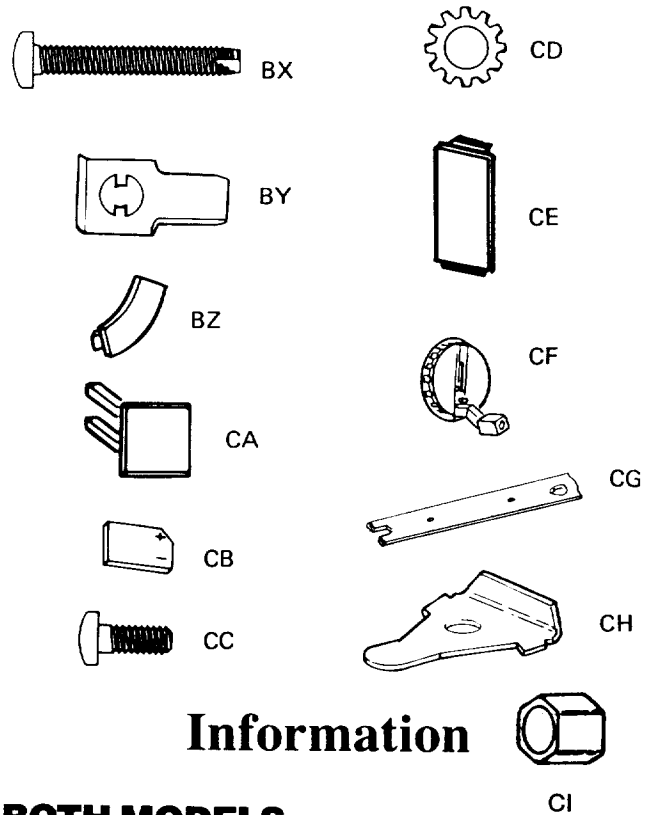

Information

BOTH MODELS

1. If you are missing any part while putting your saw together, do not continue assembly. Contact your Sears Service Center or Retail Store and get the missing part before continuing assembly or trying to use the saw.

Complete parts lists are located at the end of this manual. Use these lists to identify the number of any missing part.

2. Sometimes small parts get lost in packaging materials. Do not throw away any packaging until your saw is put together. If you are missing a part, check the packaging before contacting Sears.

3. Most parts of your radial arm saw will be fastened together using truss head bolts, lockwashers, and hex nuts of the sizes shown. (Figure 13) When different sizes are needed, the instructions will include a sketch to help you locate the correct size.



Fig. 13 - Truss Head Bolt, Lockwasher, Hex Nut

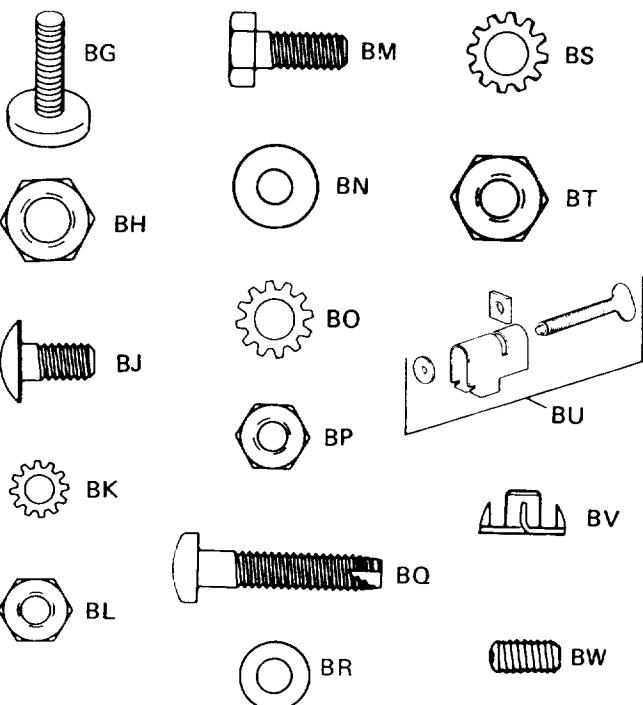

4. As you assemble your radial arm saw, some of the holes in the parts will line up and others will not. This happens because some parts are used in other equipment or for other purposes. Follow the instructions carefully. The figures will show which holes should line up in each step.

Attaching Handwheel

BOTH MODELS

1. Locate the *handwheel*, *hex bushing*, *screw*, and *lockwasher*.
2. Place the *hex bushing* inside the *handwheel*.
3. The *hex bushing* has a small flat area on it which matches a flat area on the elevation shaft.
4. Align the two above flat areas and attach the *handwheel* using a *screw* and *lockwasher*.

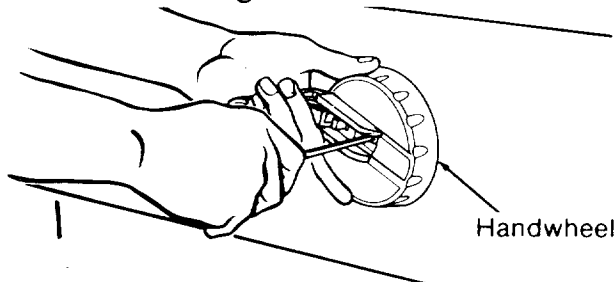

Fig. 13A



Fig. 13B - Screw, External Lockwasher and Hex Bushing

Mounting the Motor

BOTH MODELS

⚠ WARNING: Plugging the saw in during assembly can result in electrical shock or your fingers, hand, or arm being cut off from blade contact. Do not plug in the saw at any time during assembly. The saw should only be plugged in when it is to be used.

1. Loosen the *guard clamp screw* and remove the *guard* from the *motor*.
2. Use the *arbor wrenches* to remove the *blade* from the *saw*. The *arbor shaft* has left-handed threads, so you will have to turn the nut clockwise to loosen.
3. Lock the *rip lock*.
4. Turn the handwheel in a clockwise direction to raise the *radial arm* about 2 inches and remove the styrofoam packing blocks.
5. Clean the small pieces of styrofoam off the saw.
6. Place the *motor* on the center channel of the *saw* and remove the three *table boards* and *fence*.
7. Remove the lock nut and flat washer from the *motor pivot support*. (Figure 13C)

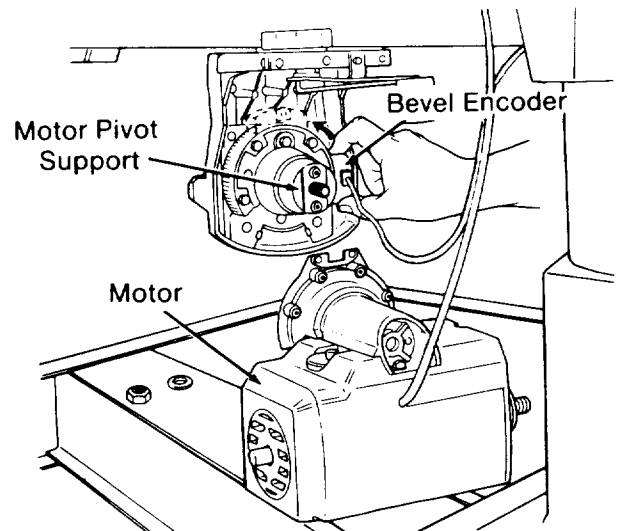

Fig. 13C

8. Slide the *bevel encoder* to the top center position so it will fit into the notch on the *motor support bracket*. (Figure 13C)
9. Slide the *motor* onto the *motor pivot support*. Make sure the *motor* is firmly in place.
10. Put the flat washer and locknut back in place and tighten using a 3/4 inch socket wrench. Move the *bevel lock* back and forth as you tighten the locknut. Do not over-tighten.

11. Push the *bevel lock* to the left as far as it will go. (Figure 13D)

12. If there is a 1/16 inch gap or less between the *bevel lock* and the left side of the *yoke* (and they are not touching), go to step 14, or

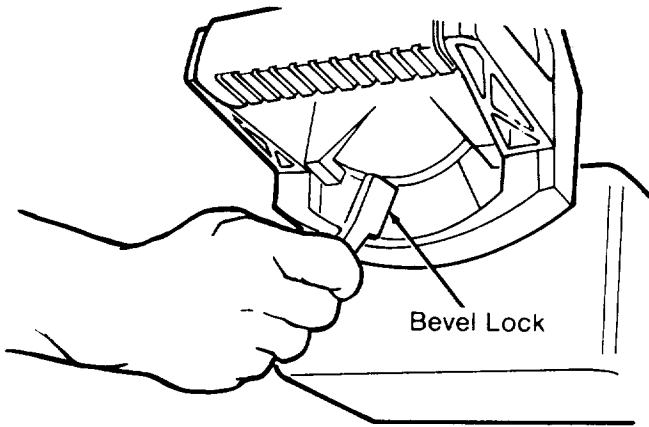

Fig. 13D

If the bevel lock touches the left side of the *yoke*, unlock the *bevel lock* and tighten the locknut on the *motor pivot support*. Then go to step 10 and repeat, or

If there is more than 1/16 inch gap between the *bevel lock* and the left side of the *yoke*, unlock the *bevel lock* and loosen the locknut on the *motor pivot support*. Then go to step 10 and repeat.

13. Repeat steps 10-11 until the *bevel lock* will not touch the left side of the *yoke*, and the gap is not more than 1/16 inch.

14. Lock the *bevel lock*.

15. Snap the *yoke plug* into place. The *yoke plug* is in the loose parts bag.

A	Right Side Panel	1
B	Left Side Panel	1
C	Lower Shelf	1
D	Skirt	2
E	Shelf Stiffener	1
F	Corner Bracket	2
G	Spacer	2
H	Door	1
I	Caster	2

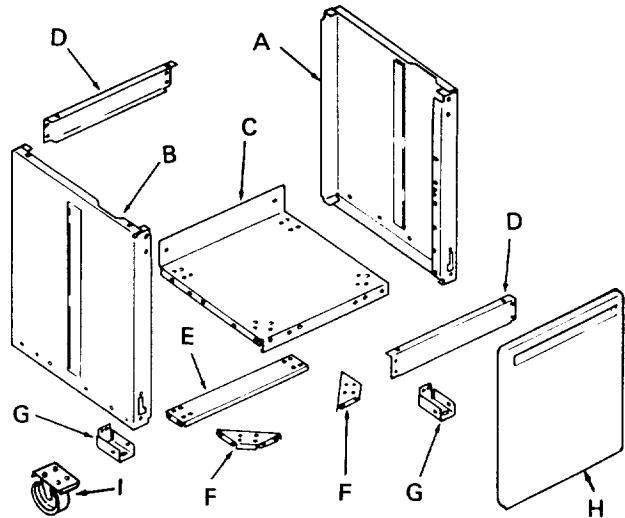

Fig. 14 - Cabinet Assembly - 113.197210

1. Turn the *shelf* upside down on the floor. The wide edge should point down, and the three narrow edges should point up. (Figure 15)

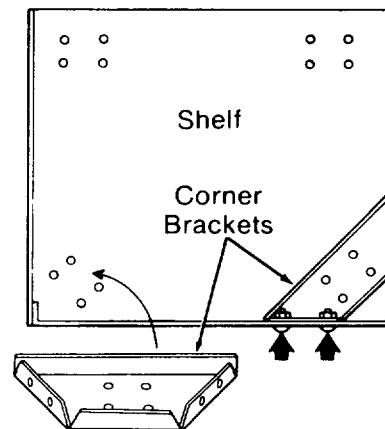

Fig. 15

2. Put a *corner bracket* in the front corners of the *shelf*. (Figure 15)

Beginning the Cabinet

MODEL 113.197210

The following parts are used in the cabinet assembly for model 113.197210:

3. Put two truss head bolts through the *shelf* and each *corner bracket* to hold the brackets in place.

4. Put a lockwasher and hex nut on each bolt and tighten with a 7/16 inch wrench or socket.

5. Put the *shelf stiffener* on the *shelf* and line up the holes. (Figure 16)

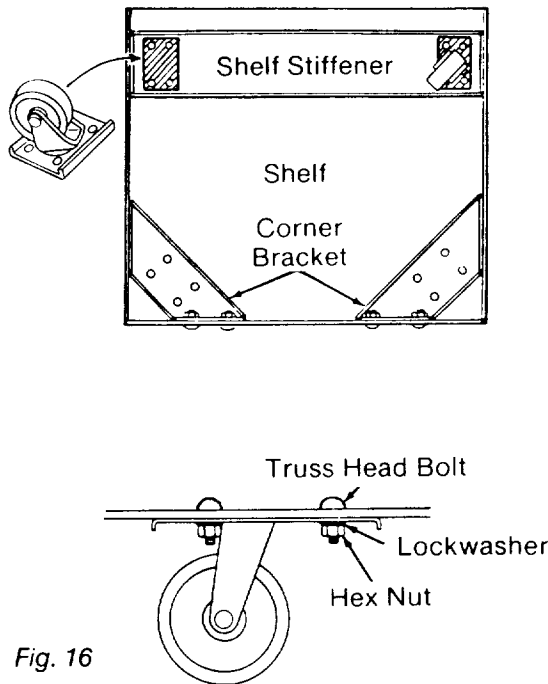

Fig. 16

6. Put the *casters (wheels)* on the *shelf* and *shelf stiffener*. Since the *shelf* is upside down, the *wheels* will point up. Line up four holes on each side. (Figure 16)

7. Put truss head bolts through the holes on each side. Put a lockwasher and hex nut on each bolt and tighten using a 7/16 inch wrench or socket.

8. Find the *right* and *left side panels*. Look carefully to find the "R" and "L" stamped in the metal near the center of the wide edge. These stamps are the easiest way to tell the *right side panel* from the *left*. (Figure 17)

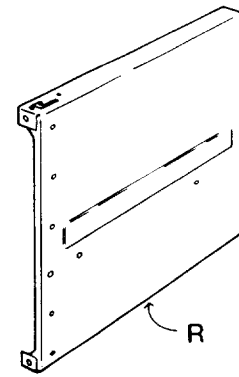

Fig. 17

9. Turn the *right side panel* so that the J-shaped slot is at the bottom and facing you.

10. Put a *spacer* inside the *right side panel* as shown. The side of the *spacer* with two round holes should be opposite the J-shaped slot in the *side panel*, and the side with one larger hole should be on the bottom. (Figure 18)

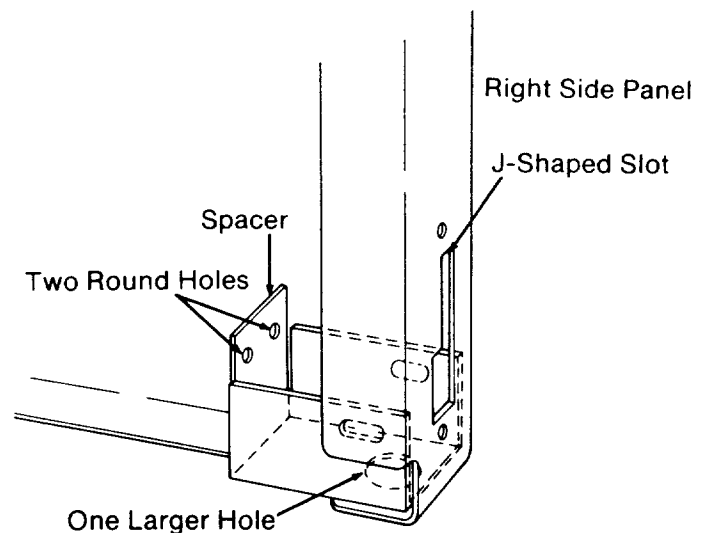

Fig. 18

11. Put two truss head bolts through *right side panel* and *spacer*, one on each side.

12. Put a lockwasher and hex nut on each bolt and tighten using a 7/16 inch wrench or socket.

13. Put a *plastic cover* over the J-shaped slot in the *side panel*. (Figure 18)

14. Repeat steps 9–13 with the *left side panel*.

15. Attach two *hinges* to the *right side panel* above the *spacer*, using four truss head bolts, lockwashers, and hex nuts. Tighten with a 7/16 inch wrench. (Figure 19)

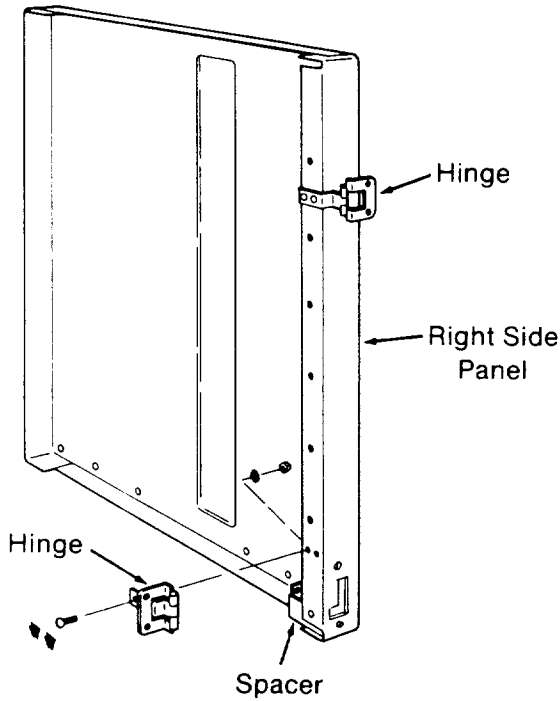

Fig. 19

16. Lay the *shelf* on the rear edge with the bottom side toward you. The angled end of the *lower support* should point up.

17. Place the *right side panel* on the right side of the *shelf*. The *spacer* should be on the inside of the cabinet. (Figure 20)

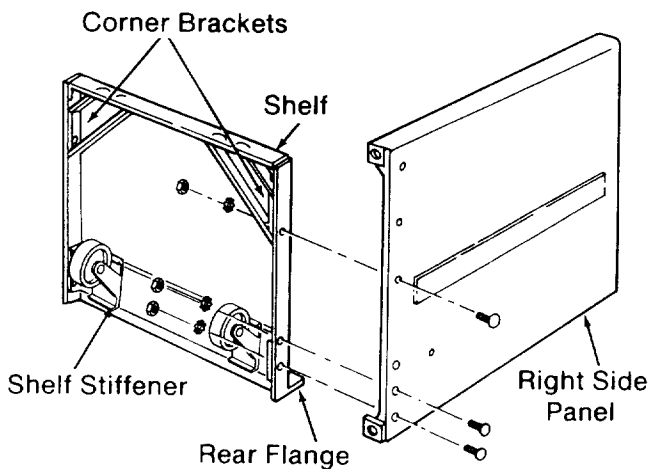

Fig. 20

18. Put truss head bolts through the three holes along the bottom edge of the *right side panel*. Put a lockwasher and hex nut on each bolt and tighten using a 7/16 inch wrench or socket. (Figure 20)

Note: It is sometimes difficult to get bolts through these three holes. You may need to use a Phillips screwdriver to help shift the parts into place.

19. Repeat steps 17-18 with the *left side panel* and the left side of the *shelf*.

20. Turn the *cabinet* right side up. Attach the *skirts* to the top of the *side panels*, with one on the front of the cabinet and the other on the back. (Figure 21)

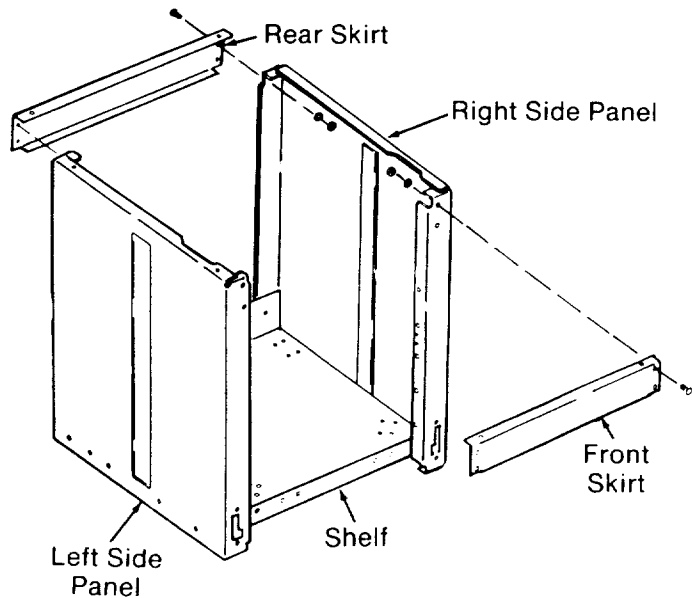

Fig. 21

21. Use eight truss head bolts, lockwashers, and hex nuts to hold the *skirts* in place. Hand-tighten. (Figure 21)

22. Put a truss head bolt through the hole at the back, right corner of the *shelf*. This hole goes through the *shelf* and the *right side panel*. (Figure 22)

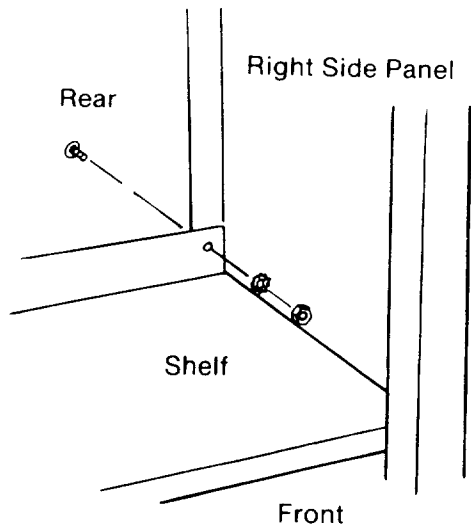

Fig. 22

23. Put a lockwasher and hex nut on the bolt and tighten using a 7/16 inch wrench or socket.

24. Repeat steps 22-23 on the left side of the shelf.

25. Put a truss head bolt through the back of the *right spacer* and front edge of the *shelf*. (Figure 23)

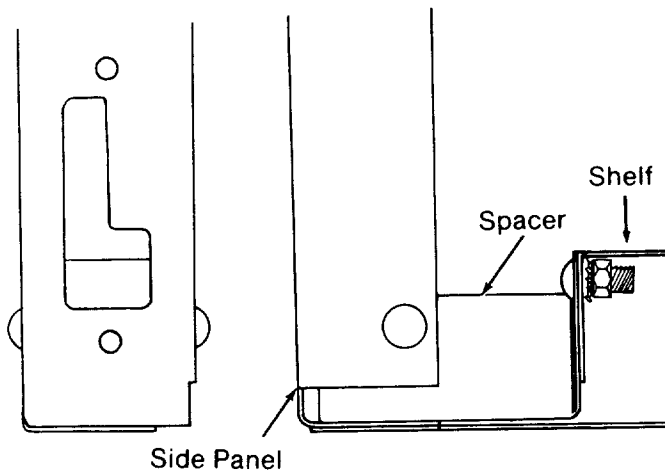

Fig. 23

26. Put a lockwasher and hex nut on the bolt and tighten using a 7/16 inch wrench or socket.

27. Repeat steps 25-26 with the *left spacer*.

28. Move the cabinet to the location where you will use your saw.

29. Put a hex nut on each of the *leveling feet*. (Figure 24)

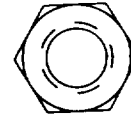

Fig. 24 - Hex Nut for Leveling Foot

30. Put the *leveling feet* through the holes in the bottom of the *side panels*, at the four corners of the *shelf*.

31. Put another hex nut on each of the *leveling feet* and hand-tighten until they are against the *side panels*.

⚠ WARNING: Saw blade can roll forward toward you if the leveling feet are not correctly adjusted. Workpiece or saw can move unexpectedly if cabinet rocks. Fingers, hand, or arm can be cut off from blade contact. Adjust leveling feet before using your saw.

32. **If the *leveling feet* raise the front of the saw slightly higher than the rear, and if the cabinet does not rock, go to step 38, or**

If the *leveling feet* do not raise the front of the saw slightly higher than the rear, go to step 33, or

If the cabinet rocks, go to step 33.

33. Loosen the bottom hex nut on the desired *leveling foot* using a 9/16 inch wrench.

34. Loosen the top nut by hand.

35. Adjust the lower nut with the 9/16 inch wrench until the *leveling foot* is at the desired height.

36. Tighten the top nut by hand.

37. Repeat steps 33-36 for the other three *leveling feet* if necessary.

38. Tighten all four bottom nuts using a 9/16 inch wrench.

Attaching Door

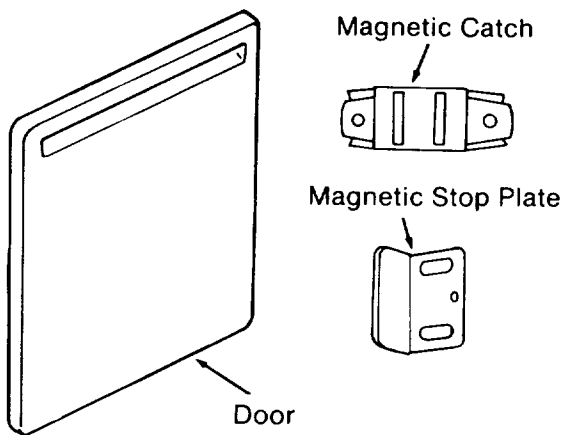

Fig. 25 - Parts for Door Assembly

1. Put a *magnetic catch* on the inside edge of the *door*. (Figure 26)

2. Fasten using two pan head screws. Tighten with a Phillips screwdriver. (Figure 26 & 27)

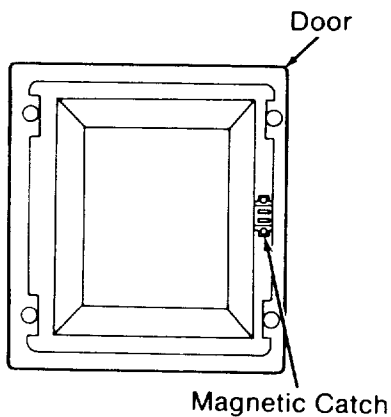

Fig. 26



Fig. 27 - Pan Head Screw

3. Attach the *door* to the *hinges* on the *side panel* using four *plastite screws*. Tighten with a Phillips screwdriver. (Figure 28)



Fig. 28 - Plastite Screw

4. Attach a *magnetic stop plate* to the two small holes on the side of the *front support* using four pan head screws. Tighten with a Phillips screwdriver. (Figures 29 & 30)

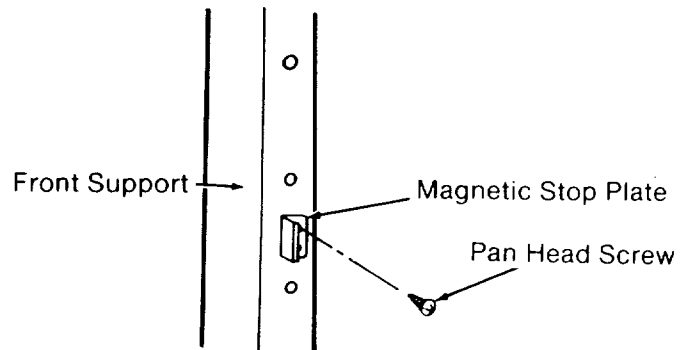

Fig. 29



Fig. 30 - Pan Head Screw

Mounting the Saw to Cabinet

1. Hold the *saw* by the front edge and the back of the column support, and lift it onto the cabinet. It may be necessary to have someone help you lift the saw. Make sure that four holes in the bottom of the *saw* line up with four holes in the top of the cabinet.

2. Fasten the *saw* to the cabinet with four truss head bolts. Put a lockwasher and hex nut on each bolt and tighten using a 7/16 inch wrench or socket. (Figure 31)

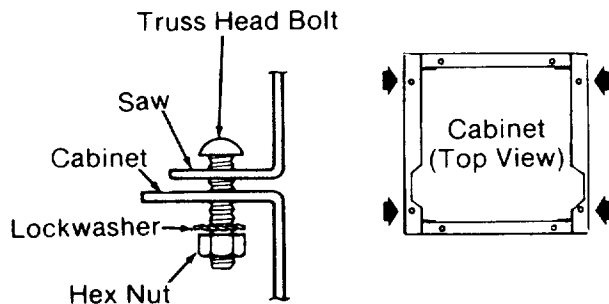

Fig. 31

3. Check all the nuts holding the cabinet together and tighten them using a 7/16 inch wrench or socket.

Attaching the Leg Set

MODEL 113.197250

1. Mount *floor leveler support brackets* inside legs. Line up the three tabs on *brackets* with slot on *leg* and tap into place. Make sure lip on *bracket* points up. (Figure 33)

Install the remaining three *brackets* the same way.

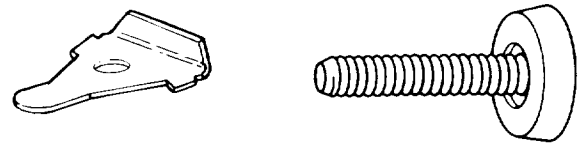

Fig. 32 - Support Bracket, Leveling Foot

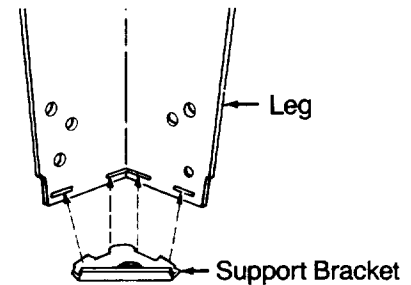

Fig. 33

2. Put a *hex nut* on each of the *leveling feet*. Put the *leveling feet* through the holes in the bottom of the *floor leveler support bracket*.

3. Put another *hex nut* on each of the *leveling feet* and hand-tighten until they are against the *leg*.

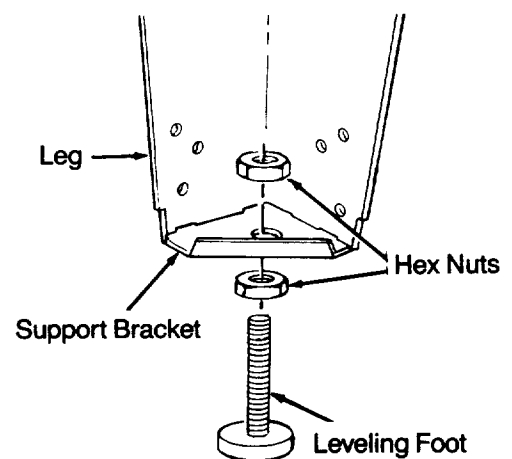

Fig. 34

Building the LEG SET

The following parts are used in the leg set assembly:

A	Legs	4
B	Lower Stiffeners	4

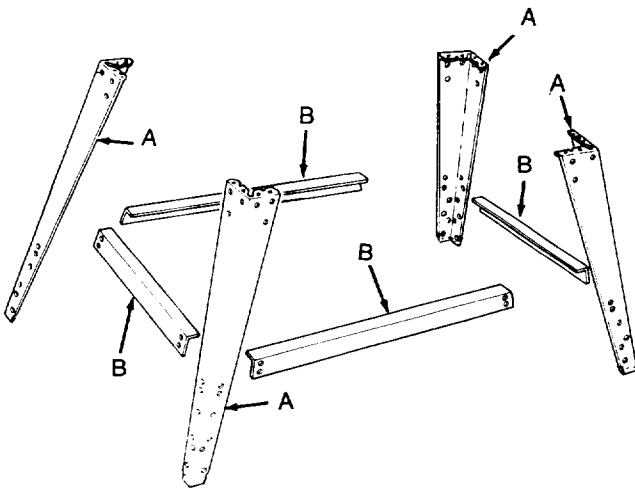

Fig. 35 - Leg Set

1. Lay a piece of cardboard on the floor to keep from scratching the *saw*.
2. Position the *basic saw assembly* on the floor as shown below. The *arm assembly* should be pointing up in a vertical position and the *column support cover* should be resting flat on the floor. It may be necessary to have someone help you lift the *saw*.

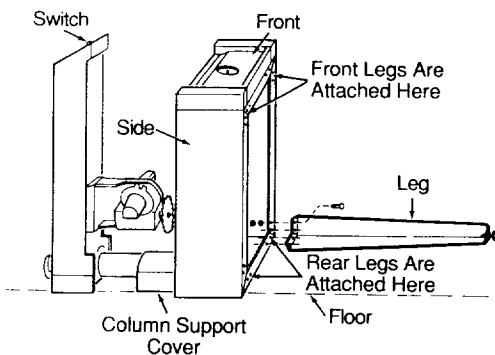

Fig. 36

3. Use *truss head bolts*, *lockwashers*, and *nuts* (see Fig. 12) to mount the two *rear legs* to the *basic saw assembly*. Make sure that the four holes in each corner of the *saw* line up with four holes in the top of each *leg*. Finger tighten nuts at this time.

4. Mount the two *front legs* to the *basic saw assembly* using *truss head bolts*, *lockwashers*, and *nuts*. However only put bolts through the *sides* of the *saw assembly* **not** the front.

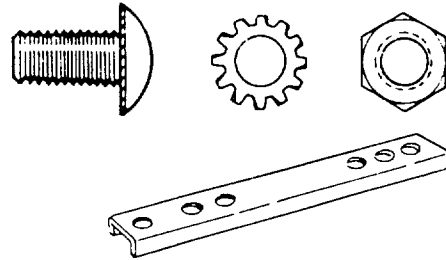

Fig. 37 - Bolt, External Lockwasher, Hex Nut, U-Channel

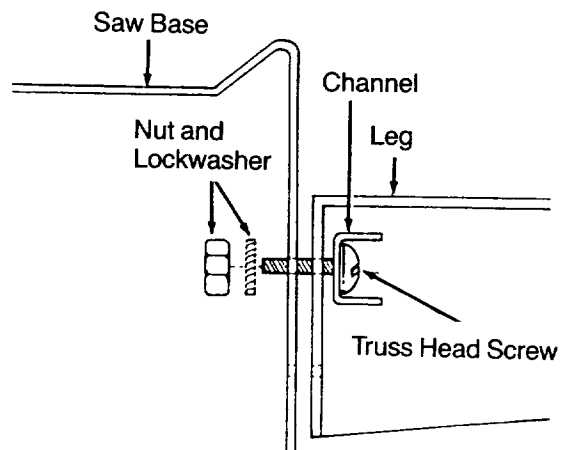

Fig. 38

5. Position the front *channel piece* inside the *legset*. (Figure 38) Fasten the *channel piece*, *leg*, and *saw* together with two *truss head bolts* on each side. Put a *lockwasher* and *hex nut* on each bolt. The threaded section of the bolt should point towards the *arm assembly*.

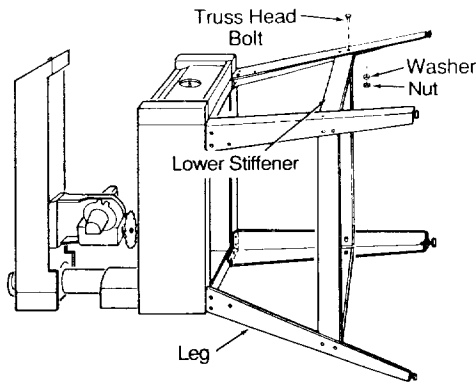

Fig. 39

6. Attach the four (4) *lower stiffeners* to the *legs*. Two (2) *truss head bolts*, *washers*, and *nuts* are required to hold each end of a *lower stiffener* in place. Hand tighten *hex nuts*.

7. Go back with a 7/16 wrench or socket and tighten all hex nuts.

8. Carefully lift the saw into its normal position. It will be necessary to have someone help you in order to avoid damaging the saw.

Adjusting Leveling Feet

⚠ WARNING: Saw blade can roll forward toward you if the leveling feet are not correctly adjusted. Workpiece or saw can move unexpectedly if cabinet rocks. Fingers, hand, or arm can be cut off from blade contact. Adjust leveling feet before using your saw.

1. If the *leveling feet* raise the front of the *saw* slightly higher than the rear, **and** if the *leg set* does not rock, go to step 13, **or**

If the *leveling feet* do not raise the front of the *saw* slightly higher than the rear, go to step 8, **or**

If the *leg set* rocks, go to step 8.

2. Loosen the bottom hex nut on the desired *leveling foot* using a 9/16 inch wrench.

3. Loosen the top nut by hand.

4. Adjust the lower nut with the 9/16 inch wrench until the *leveling foot* is at the desired height.

5. Tighten the top nut by hand.

6. Repeat steps 8-11 for the other three *leveling feet* if necessary.

7. Tighten all four bottom nuts using a 9/16 inch wrench.

Attaching Trim Caps

BOTH MODELS

1. Find the left and right *trim caps*.

2. There are two plastic stubs on the back of each *trim cap*.

3. These stubs will snap into matching holes at the front corners of the *saw*.

4. Snap the left and right *trim caps* into place.

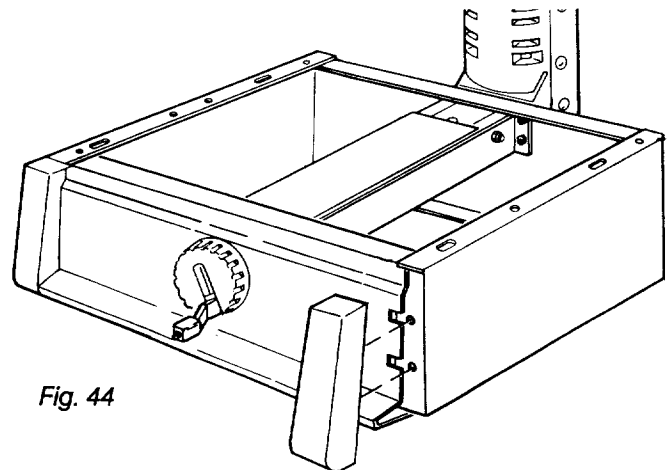

Fig. 44

Location and Function of Controls



113.197210

Fig. 45 - Radial Saw Controls

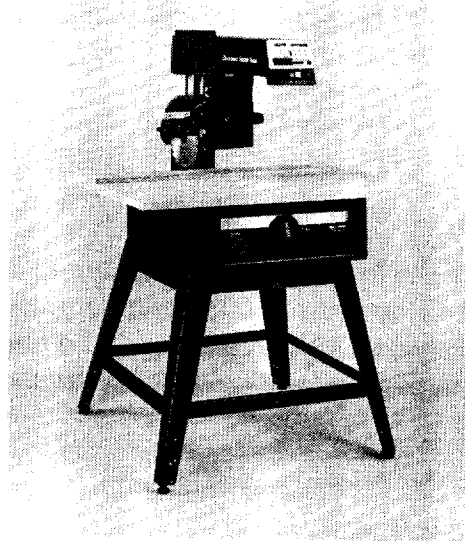

113.197250

On/Off Switch

The on/off switch turns the power to the saw on and off.

To turn the saw on, put the *yellow key* into the *red switch* and then pull the *switch* to the right. To turn the saw off, push the *red switch* to the left. Remove the *yellow key* from the *red switch* whenever the saw is turned off, and keep it out of the reach and sight of children. (Figure 46)



Fig. 46 - On/Off Switch

⚠ WARNING: The saw can start accidentally or be used by children and others when the yellow key is left in the red switch. Always remove the yellow key when the saw is off, and keep it out of the reach and sight of children.

⚠ WARNING: The saw will start immediately when the power comes back on after a blackout if the red switch is left on. Always turn the switch off and remove the yellow key when the power goes off for any reason.

Miter Lock

The miter lock is used to hold the radial arm at various angles to the fence.

To unlock the *miter lock*, pull the lock to the right. (Figure 47)



Fig. 47 - Miter Lock - Unlocked

To lock the *miter lock*, push the lock to the left. (Figure 48)

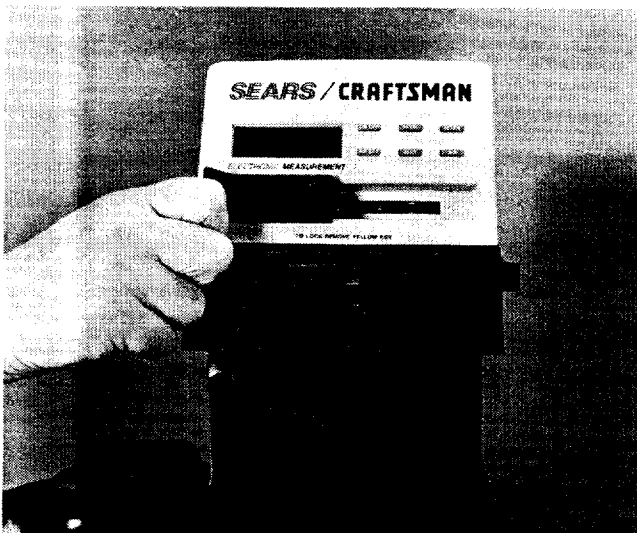

Fig. 48 - Miter Lock - Locked

There are three pre-set miter angles at 45° , 0° , and -45° . You will feel the radial arm snap into position at these miter angles. To unlock the arm when it is in one of these positions, pull the *miter lock* all the way to the right and move the *arm* as you hold the *lock* in this position.

Bevel Lock

The bevel lock is used to hold the blade at various angles to the table. To unlock the *bevel lock*, move the lock to the right. Always hold the *motor* when you unlock the *bevel lock*. (Figure 49)

⚠ CAUTION: The motor is heavy and can swing down quickly. You can be cut or injured by the arbor shaft or blade. Hold the motor when you unlock the bevel lock.

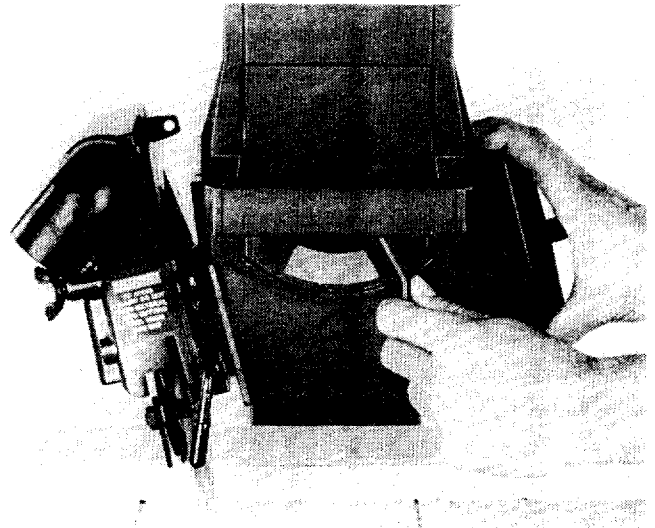

Fig. 49 - Bevel Lock - Unlocked

To lock the *bevel lock*, move the lock to the left. (Figure 50)

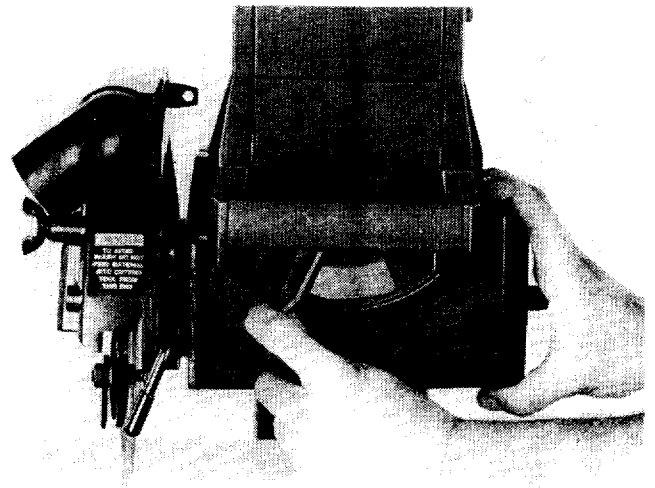

Fig. 50 - Bevel Lock - Locked

There are five pre-set bevel angles at -90° , -45° , 0° , 45° , and 90° . To unlock the *bevel lock* when the blade is at one of these angles, move the *bevel lock* all the way to the right and turn the *motor* while holding the *lock* in this position.

Swivel Lock

The swivel lock is used to hold the blade in the crosscut, in-rip, or out-rip positions, and to position the blade for molding or edging. To unlock the *swivel lock*, stand facing the *saw handle* and pull the *swivel lock* toward you. (Figure 51)

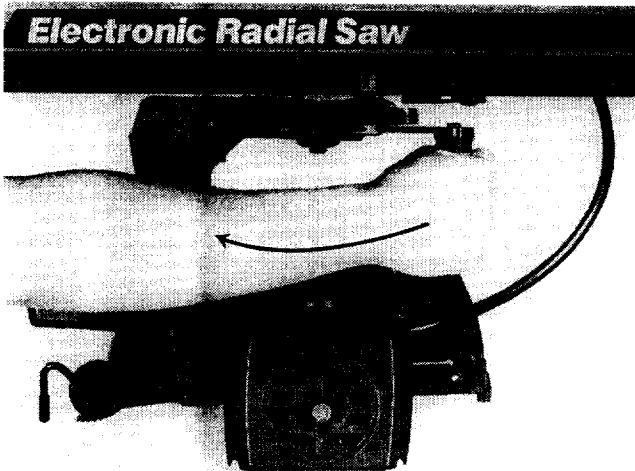

Fig. 51 - Swivel Lock - Unlocked

To lock the *swivel lock*, stand facing the *saw handle* and push the *swivel lock* away from you. (Figure 52)



Fig. 52 - Swivel Lock - Locked

The crosscut, in-rip, and out-rip positions of the blade are pre-set positions. To unlock the

swivel lock when the *motor* is in one of these positions, stand facing the *saw handle*, pull the *swivel lock* all the way toward you, and turn the *motor* as you hold the *lock* in this position.

Rip Lock

The rip lock is used to hold the motor and blade at a fixed position along the radial arm. It is used during ripping to hold the blade a desired distance from the fence while the workpiece is fed through. It is used before and after each crosscut to keep the blade from moving forward on its own.

To unlock the *rip lock*, pull the handle toward the front of the *arm*. (Figure 53)

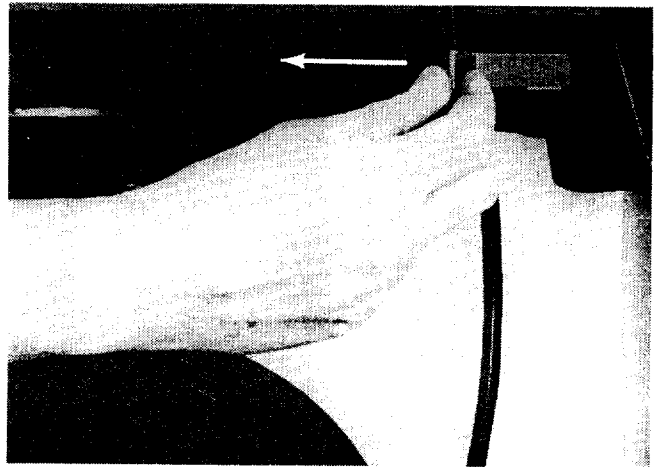

Fig. 53 - Rip Lock - Unlocked

To lock the *rip lock*, push the handle toward the rear of the *arm*. (Figure 54)

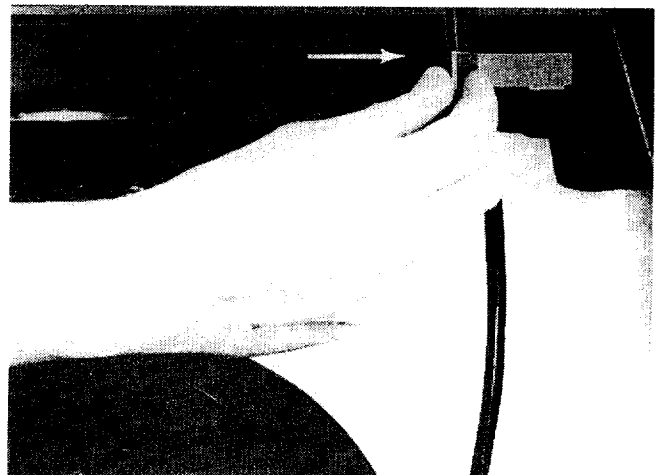

Fig. 54 - Rip Lock - Locked

Handwheel

The handwheel controls the height of the radial arm.

To raise the *radial arm*, turn the *handwheel* clockwise. To lower the *radial arm*, turn the *handwheel* counterclockwise. (Figure 55)



Fig. 55 - Handwheel

One complete turn of the handwheel moves the arm 1/16 inch.

The handle can be folded in by squeezing the red plastic "ears" with your thumb and index finger while pushing the handle in.

All Controls

Always lock the miter, swivel and bevel locks before making a cut on your radial arm saw. When ripping, the rip lock must also be locked. When crosscutting, the rip lock should be locked before and after each cut, when the saw is in the rearmost position.

Alignment of the Blade

ALIGNMENT OF THE BLADE IS THE MOST IMPORTANT STEP IN ASSEMBLING YOUR RADIAL ARM SAW.

The blade of your radial arm saw must be aligned properly for two reasons: to make cuts accurate, and to prevent binding of the blade and workpiece which can cause jams or thrown workpieces.

These adjustments must be done **in order**, before using your saw for the first time. If they are not done in order the saw will not cut accurately. If you miss an adjustment, you must go back to the adjustment you missed and repeat **all** steps from that point on.

These adjustments are like fine tuning a piece of equipment. Often a series of steps must be repeated more than once in order to get the adjustment just right.

⚠ WARNING: Plugging the saw in during alignment can result in electrical shock or your fingers, hand, or arm being cut off from blade contact. Do not plug in the saw at any time during alignment. The saw should only be plugged in when it is to be used.

Make sure that the blade and blade guard are removed from the arbor shaft before beginning to align your saw. Do not install the blade or blade guard until you are instructed to do so.

Adjusting Elevation

The goal of this adjustment is to make upward and downward movement of the radial arm smooth and firm. If the column that supports the arm is too tight it will be difficult to move the arm up and down and to get accurate depth of cut. If the column is loose the blade may "walk" on the workpiece and stall the motor, or cause a heel in bevel and compound cuts.

1. Use a 3/16 hex "L" wrench to loosen the four screws in the front of the *column support*. (Figure 56)

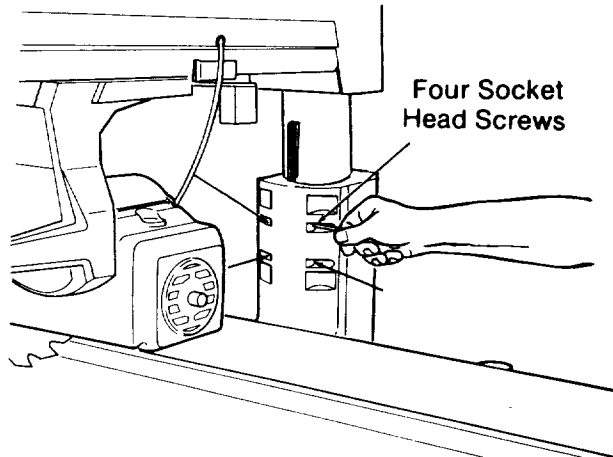

2. Raise and lower the *radial arm* by turning the *handwheel* a few turns in each direction. It should take about the same amount of effort to lower the *arm* as to raise it.

3. If movement seems smooth and the *column* does not rock back and forth, go to the next section, or

If movement seems difficult, loosen the four bolts in the back of the *column* slightly (Figure 57) and go back to step 2, or

If *column* rocks back and forth, tighten the four bolts in the back of the *column* slightly (Figure 57) and go back to step 2.

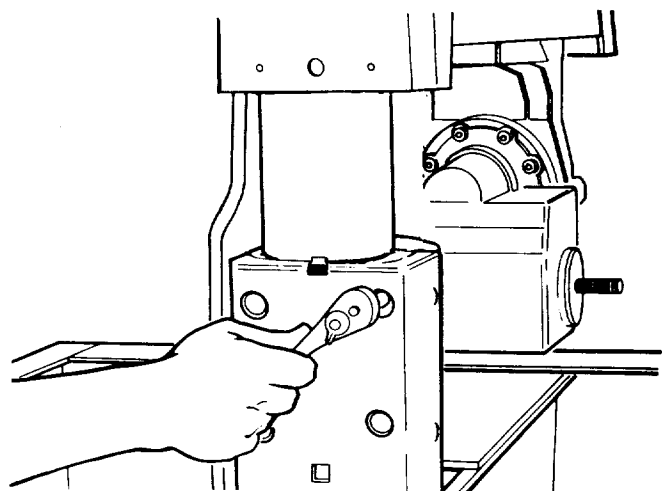

Fig. 57

Leveling Table Supports

1. Raise the *radial arm* until the bottom of the *motor* is about 2-1/2 inches above the *saw*.

2. Locate four hex head bolts and put a flat washer on each.

3. Attach a *table support* to each side of the *saw* using the four hex head bolts and flat washers. (Figure 58 & 59) Put the bolts through the center of the enlarged holes in the *table supports* so that the *supports* may slide up or down as needed.

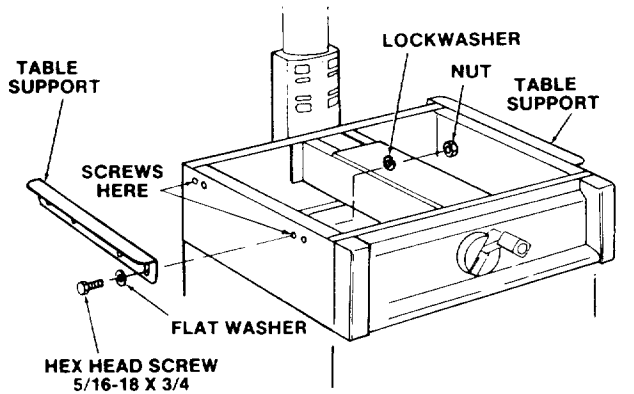

Fig. 58

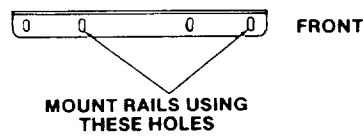

Fig. 59 - Hex Head Bolt, Washer, Lockwasher and Hex Nut

4. Put a lockwasher and hex nut on each bolt and hand-tighten.

5. Unlock the *bevel lock* to release the motor. Hold onto the *motor* as you do this.

CAUTION: The motor is heavy and can swing down quickly. You can be cut or injured if the arbor shaft hits you. Hold the motor when you unlock the bevel lock.

6. Turn the *motor* until the *arbor shaft* is pointing straight down toward the *saw*. (Figure 60)

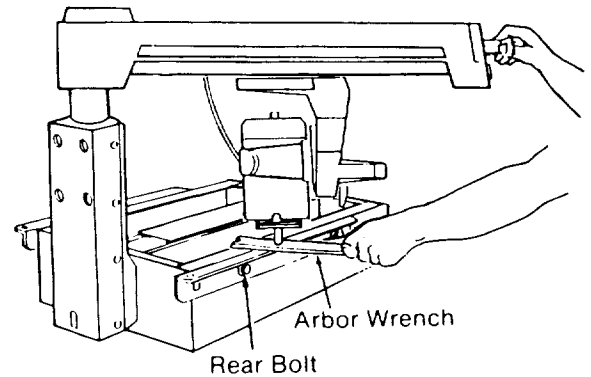

Fig. 60

7. Lock the *bevel lock* to hold the *motor* in this position.

8. Unlock the *miter lock* and move the *arm* to the left as far as it will go (about 50° miter).

9. Unlock the *rip lock* and move the *motor* until the *arbor shaft* is over the left *table support*. (Figure 60)

10. Mark the point on the *table support* under the center of the *arbor shaft*.

11. Place the *arbor wrench* over this point and lower the *arm* until the *arbor shaft* is just touching the *wrench*. The *wrench* should slide back and forth with slight contact. (Figure 60)

12. Tighten the rear bolt under this point using a 1/2 inch wrench.

13. Move the *arm* and *motor* until the *arbor shaft* is over the front bolt on the left *table support*. Do not change the elevation of the *arm* as you move from point to point. (Figure 61)

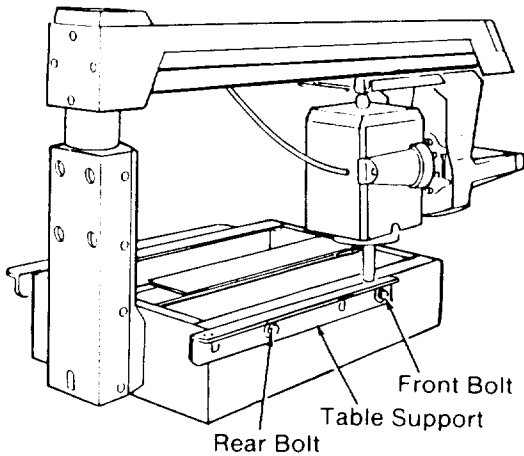

Fig. 61

14. Mark the point on the *table support* under the center of the *arbor shaft*. (Figure 62)

15. Place the *arbor wrench* over this point. (Figure 62)

16. Slide the front end of the *table support* up or down until the handle end of the *arbor wrench* just fits between this point and the *arbor shaft*. The *wrench* should slide back and forth with slight contact.

17. Tighten the bolt under this point using a 1/2 inch wrench.

18. Repeat steps 13-17 with the *arbor shaft* over the front and rear bolts on the right *table support*. Slide the rear end of the *table support* up or down when the *arbor shaft* is over the rear bolt (see step 16).

19. Move the *arbor shaft* over all four points again.

20. Place the *arbor wrench* over each point and make sure that the *arbor shaft* just touches the *wrench*. The *wrench* should slide back and forth with slight contact.

21. **If** the *arbor shaft* just touches the *arbor wrench* at each point, go to the next section, **or**

If the *arbor wrench* will not fit between the *arbor shaft* and the *table support* at any point, repeat steps 8-21 until the *table supports* are level, **or**

If there is a gap between the *arbor wrench* and the *arbor shaft* at any point, repeat steps 8-21 until the *table supports* are level.

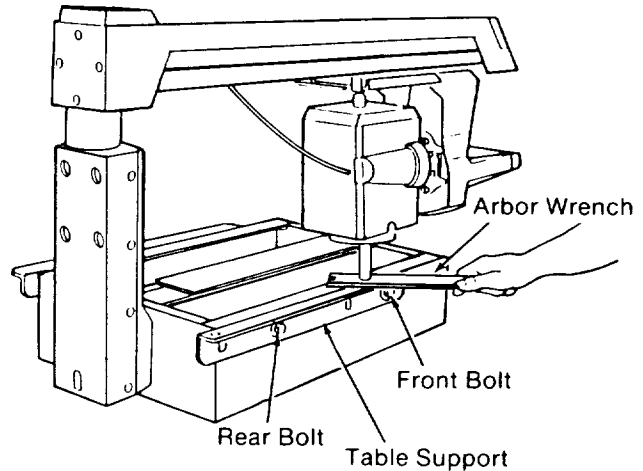

Fig. 62

Mounting the Front Table

1. Make sure that the *front table* is upside down.

2. Place a *tee nut* over the *leveling hole* and hammer it into place. (Figure 63 & 64)

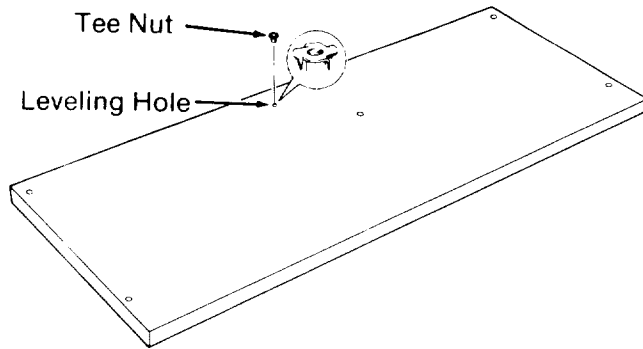

Fig. 63



Fig. 64 - Nut Tee

3. Slide a *U-clip* onto the center channel of the *saw* as shown. (Figure 65 & 66)

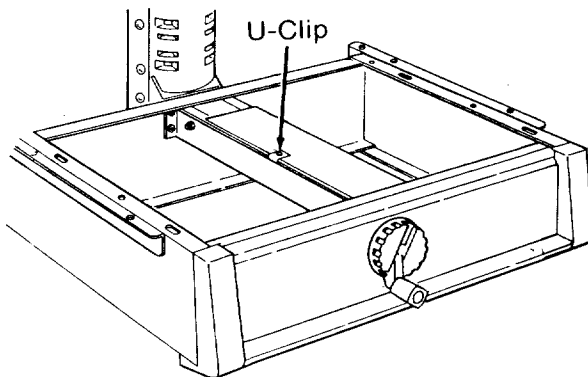

Fig. 65



Fig. 66 - U Clip

4. Place the *front table* on the *saw* so that the *mounting holes* in the *table* line up with holes in the *table supports* and center channel of *saw*. (Figure 67)

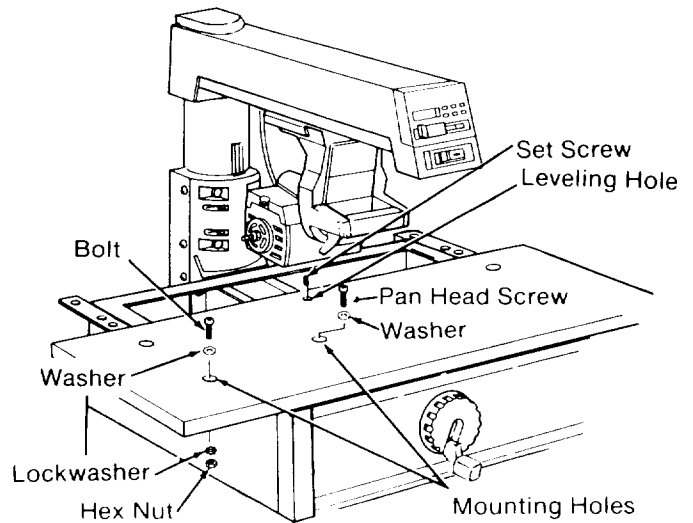

Fig. 67

5. Start the *cup point set screw* through the *leveling hole*. Do not tighten. (Figures 67 & 68)



Fig. 68 - Cup Point Set Screw

6. Put a *washer* in each of the *mounting holes*. (Figures 67 & 69)

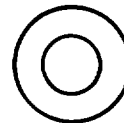

Fig. 69 - Washer for Mounting Holes

7. Start a *pan head machine screw* through the center *mounting hole*. Do not tighten. (Figures 67 & 70)

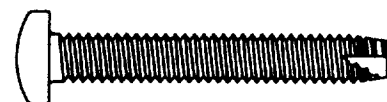

Fig. 70 - Pan Head Machine Screw

8. Install the *pan head bolts through the other four mounting holes*. Put a lockwasher and hex nut on each bolt and tighten using a Phillips screwdriver. (Figures 67 & 71)



Fig. 71 - Pan Head Bolt

9. Lay the edge of the *rear table* across the center of the *front table*, and check to see if there is a gap between the two. (Figure 72)

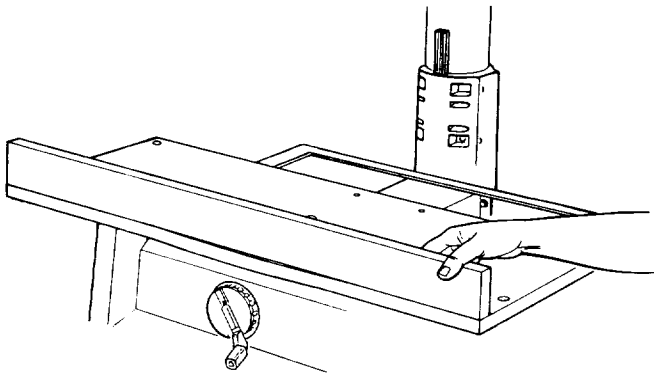

Fig. 72

10. **If** there is a gap larger than 1/32 inch, go to step 11, **or**

If there is a gap less than 1/32 inch, or no gap at all, tighten the *leveling screw* and the center *mounting screw*. Do not overtighten. Then go to step 12.

11. **If** the gap is at the center of the *table*, tighten the *leveling screw* until the gap is gone. Then tighten the center *mounting screw* and go to step 12, **or**

If the gap is at the sides of the *table*, tighten the center *mounting screw* until the gap is gone. Then tighten the *leveling screw* and go to step 12.

12. Lay the edge of the *rear table* across the center of the *front table* and check again for gaps.

13. **If** there is a gap larger than 1/32 inch, go back to step 11 and repeat, **or**

If there is a gap less than 1/32 inch, or no gap at all, go to the next section.

Squaring Crosscut Travel

The blade must travel perpendicular to the fence along the radial arm in order for crosscuts to be accurate. If the radial arm is not perpendicular to the fence, there will be a slight miter angle in all crosscuts.

⚠ WARNING: Plugging in the saw during alignment can result in your fingers, hands, or arm being cut off from blade contact. Do not plug in the saw at any time during alignment. The saw should only be plugged in when it is to be used.

1. Place the *radial arm* in the 0° miter position and lock the miter lock.
2. Raise the *radial arm* about 2 inches above the front table.
3. Unlock the *bevel lock*, and turn the *motor* so that the *arbor* is perpendicular to the *table*. (Figure 73)

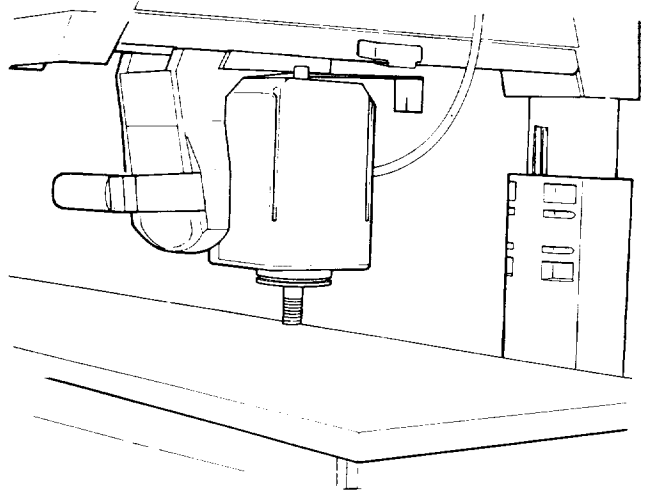

Fig. 73

4. Unlock the *rip lock* and move the *motor* until the *motor arbor* is over the *front table*.
5. Lock the *rip lock*, *miter lock* and *bevel lock*.
6. Lower the *radial arm* until the *motor arbor* is slightly above front table.

7. Lay a framing square on the *front table* with the long edge along the back of the *table* and the short edge alongside the *motor arbor*. (Figure 74)

8. Move the framing square toward the *motor arbor* until the arbor and square touch each other. (Figure 74)

9. Unlock the *rip lock* and move the *motor arbor* back and forth along the *radial arm* as shown by the arrows. Do not move the framing square.

10. If the *motor arbor* just touches the square at all points, no change is needed. Go to step 15, or

If the *motor arbor* moves away from the square or tries to “walk” on top of it, go to step 11. (Figure 74)

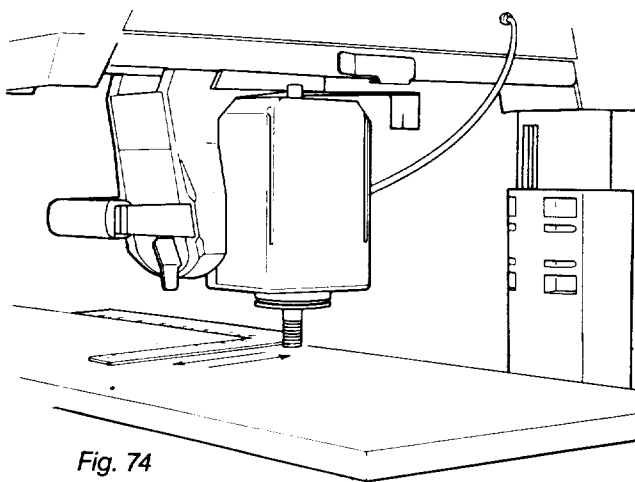

Fig. 74

11. Use 3/16 hex “L” wrench to loosen the four screws in the front of the *column support* slightly, if you have not already done so in the Adjusting Elevation section. (Figure 75)

12. Use the top two screws to move the *radial arm* into line:

If the *motor arbor* moved away from the square, tighten the top right screw to move the *arm* to the left. Then tighten the top left screw to meet the *column*. Go to step 14, or

If the *motor arbor* tried to “walk” on the square, tighten the top left screw to move the *arm* to the right. Then tighten the top right screw to meet the *column*. Go to step 13.

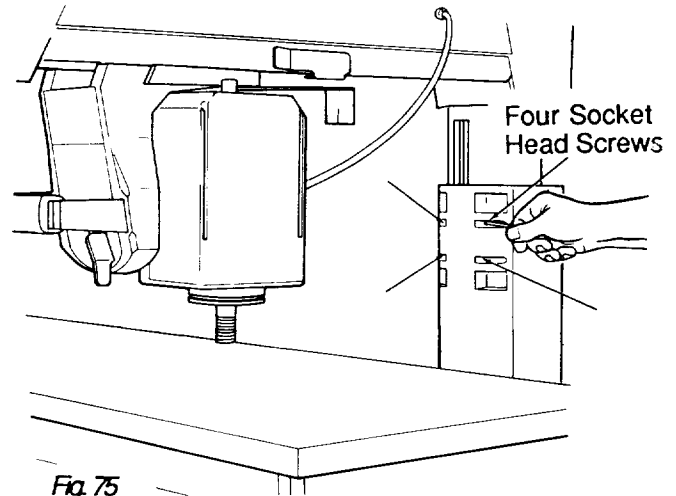

Fig. 75

13. Move the *motor* back and forth along the *radial arm*. Repeat step 12 until the *motor arbor* just touches the square at all points. Then go to step 14.

14. Tighten the bottom screws in the front of the *column support*, switching from right to left several times so that you do not force the *radial arm* out of line. Do not overtighten or it will be difficult to raise and lower the *radial arm*.

15. Raise and lower the *radial arm*. If this is difficult, loosen the four screws in the front of the *column support* slightly and try again. Loosen all of these screws the same amount so that you do not force the *radial arm* out of line.

16. Repeat step 15 until movement of the *radial arm* is smooth but firm. Then go to step 17.

17. Lay a framing square on the *front table* with the long edge along the back of the *table* and the short edge alongside the *blade*, as before.

18. Move the framing square towards the *motor arbor* until the arbor and square touch each other.

19. Move the *motor arbor* back and forth along the *radial arm*. Do not move the square.

20. If the *motor arbor* just touches the edge of the square at all points, go to step 21, or

If the *motor arbor* moves away from the edge of the square or tries to “walk” on top of it, go back to step 12 and repeat.

21. Lock the *rip lock*, put the *spacer*, *fence* and *rear table* back in place, lock the *table clamp*, and go to the next section.

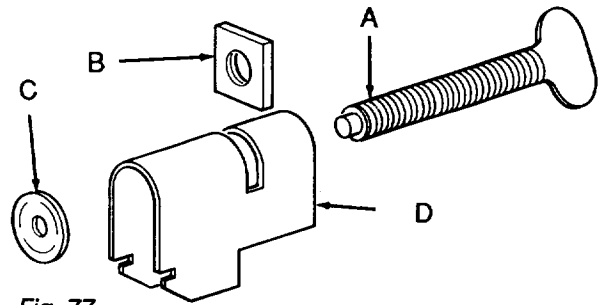
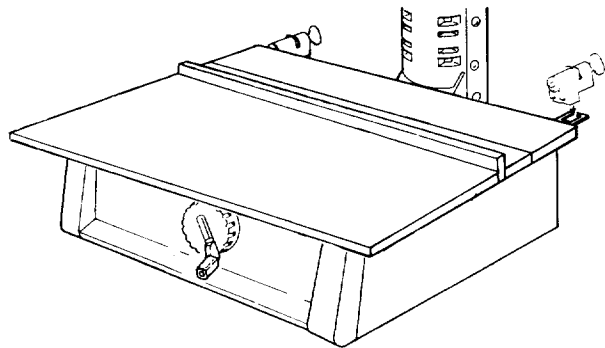

Fig. 77

1. Drop square nut in slot at top of clamp bracket.
2. Turn thumbscrew clockwise until the point comes approximately 1/2" out other end.
3. Attach cup washer.
4. Tilt clamp bracket forward and snap in place in rectangular shaped hole at back of table support.



5. Repeat steps 1 through 4 with the other table clamp.

Squaring Blade to Table for Crosscutting

These steps are necessary so that your blade will be perpendicular to the table and cuts will be accurate. If this is not done correctly, your cuts will have a slight bevel angle.

1. Place the *radial arm* in the 0° miter position and lock the miter lock.
2. Place the *blade* on the *arbor shaft* with a *blade collar* on each side. Make sure that the directional arrow is on the outside of the *blade*, and the teeth are pointing down at the front side of the blade. (Figure 79)

Positioning Rear Table Boards and Fence

1. Position the *rip fence* next to the *front table* as shown.

2. Next drop in the *table spacer* and then the *rear table*.

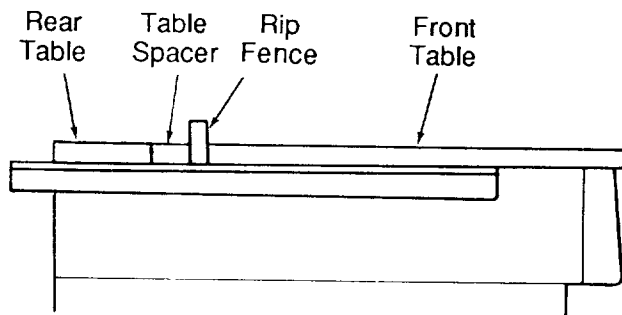

Fig. 76

Mounting Table Clamps

The following parts are used in mounting the table clamps:

A	Thumbscrews	2
B	Square Nuts	2
C	Cup Washer	2
D	Clamp Bracket	2

3. Place the *arbor nut* on the *arbor shaft* and use the *arbor wrenches* to tighten. The *arbor shaft* has left-handed threads, so you will have to turn the nut counterclockwise to tighten. Do not overtighten.

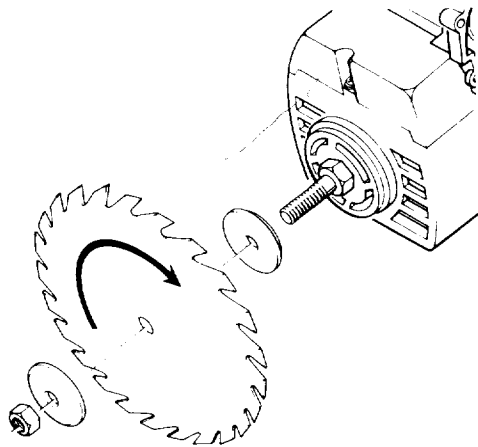

Fig. 79

CAUTION: Overtightening the arbor nuts may cause the blade collars to warp and the blade to wobble while cutting. Use the arbor wrenches to tighten the arbor nuts but do not overtighten.

4. Lock the *table clamps* and *rip lock*.

5. Place the long edge of the framing square on the *table* and the short edge against the *blade*. Make sure that the square is against the blade surface and not the set of a tooth. (Figure 80).

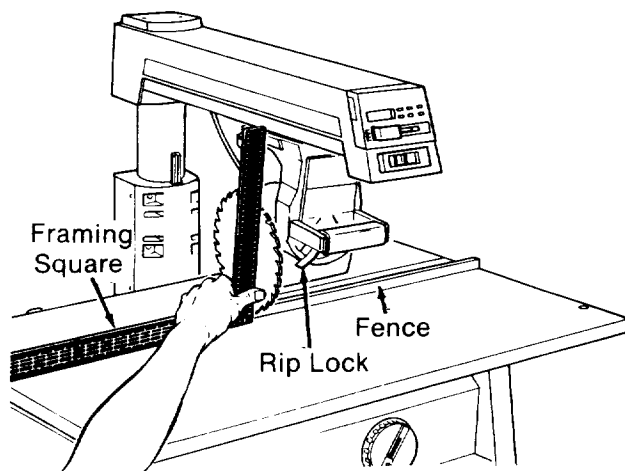

Fig. 80

6. Turn the *blade* with your hand several times and check to see if the square is flush with the *blade*.

7. If the square is flush with the *blade* after each rotation, no change is needed. (Figure 81) Go to the next section, or

If there is a gap between the square and the *blade* after any rotation (Figure 81), go to step 8. **Note:** Saw blades are manufactured to different specifications. Therefore a small gap is permissible on some brands.

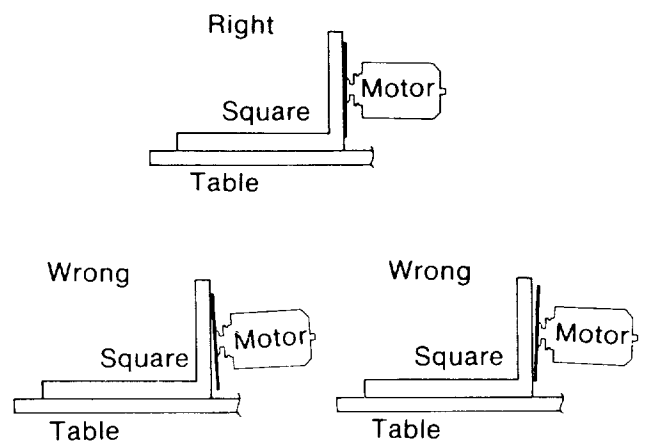

Fig. 81

8. Unlock the *bevel lock*, but do not pull the *index pin*.

9. Loosen the four screws behind the *yoke* using a 3/16 inch hex-L wrench. (Figure 82)

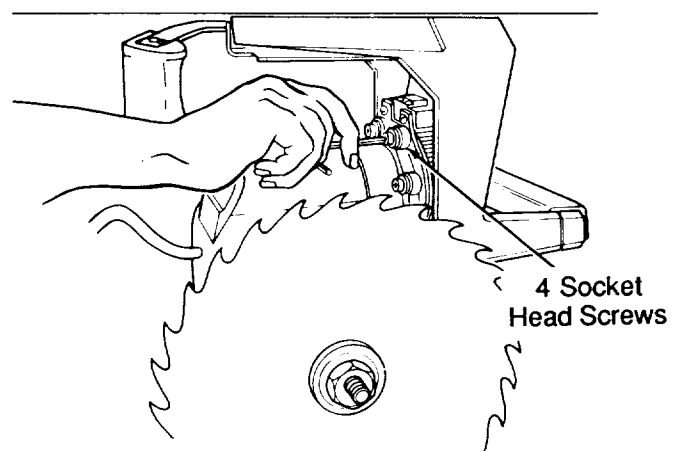

Fig. 82

10. Hold the square in place and move the *motor* slowly until the square is flush with the *blade*.

11. Hold the *motor* tightly and lock the *bevel lock*. Do not let the *motor* move out of place.

12. Check the square to make sure that it is still flush with the *blade*.

13. Tighten the four screws behind the *yoke*.

14. Raise the *radial arm* until the *blade* is 1-1/2 inches above the *table*.

15. Unlock the *bevel lock* and move the *motor* to the 45° bevel position. (Figure 83)

⚠ CAUTION: The motor is heavy and can swing down quickly. You can be cut or injured if the blade hits you. Hold the motor when you unlock the bevel lock.

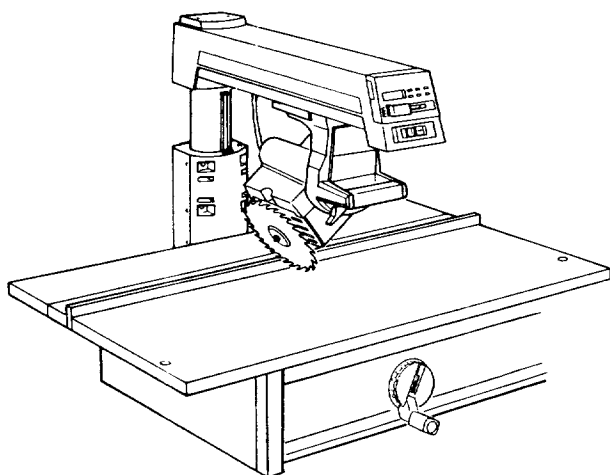

Fig. 83

16. Move the *motor* back to the 0° bevel position and lock the *bevel lock*.

17. Lower the *radial arm* until the *blade* is just above the *table*.

18. Place the long edge of the framing square on the *table* and the short edge against the *blade* as before. Make sure the square is against the surface of the *blade* and not the set of a tooth.

19. Turn the *blade* with your hand several times and check to see if the square is flush with the *blade*.

20. If the square is flush with the *blade* after each rotation, go to the next section, or

If there is a gap between the square and the *blade* after any rotation, go back to step 8 and repeat.

Squaring Blade to Fence

These steps are done so that your blade will be perpendicular to the fence. This will help reduce the risk of kickback when ripping, and splintering of the workpiece and burning of the kerf when ripping and crosscutting.

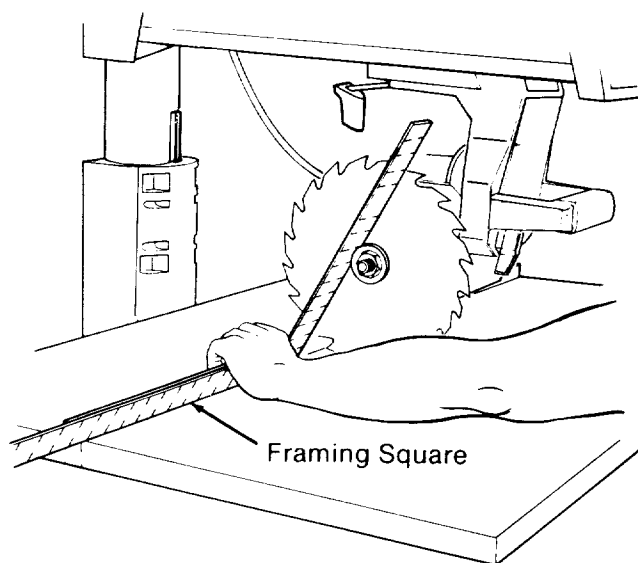

Fig. 84 - Squaring Blade to Fence

1. Put the *radial arm* in the 0° miter position with the *blade* just in front of the *fence*. (Figure 84)

2. Lock the *rip lock*.

3. Place the framing square with the long edge against **both** the *fence* and the *table*, and the short edge against the *blade* just above the *arbor shaft*. Make sure that the edge of the square is on the *blade* and not on the set of a tooth. (Figure 84)

4. Turn the *blade* with your hand several times and check to see if the square is flush with the *blade*.

5. If the square is flush with the *blade* after each rotation, no change is needed. (Figure 85) Go to the next section, or

If there is a gap between the square and the *blade* after any rotation, go to step 6. (Figure 85)

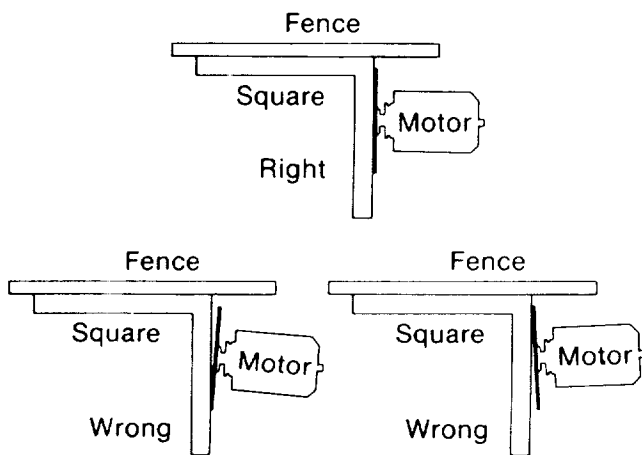

Fig. 85

6. Unlock the *swivel lock*.

7. Loosen the four screws under the *yoke* using a 3/16 inch hex-L wrench and pliers if necessary. (Figure 86)

⚠ WARNING: The hex-L wrench may break when used with pliers to loosen screws. Thrown pieces could hit you in the face and/or eyes. Wear safety goggles when using a hex-L wrench with pliers.

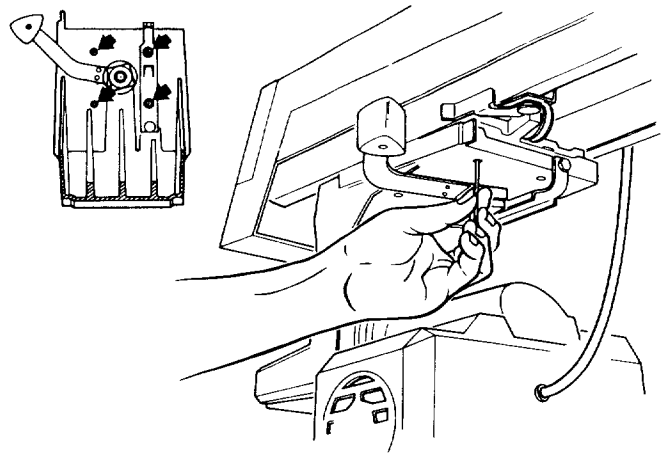

Fig. 86

8. Hold the square in place and turn the *motor* until the square is flush with the *blade*.

9. Hold the *saw handle* tightly and lock the *swivel lock*.

10. Check the square to make sure it is still flush with the *blade*.

11. Tighten the four screws under the *yoke* using a 3/16 inch hex-L wrench.

12. Place the framing square with the long edge against **both** the *fence* and the *table*, and the short edge against the *blade* just above the *arbor shaft*, as before. Make sure that the edge of the square is on the *blade* and not on the set of a tooth.

13. Turn the *blade* with your hand several times and check to see if the square is flush with the *blade*.

14. If the square is flush with the *blade* after each rotation, go to the next section, or

If there is a gap between the square and the *blade*, go back to step 6 and repeat.

Squaring Blade to Table for Ripping

1. Unlock the *swivel lock* and turn the *motor* to the out-rip position with the *motor* between the *blade* and *fence*. (Figure 87)

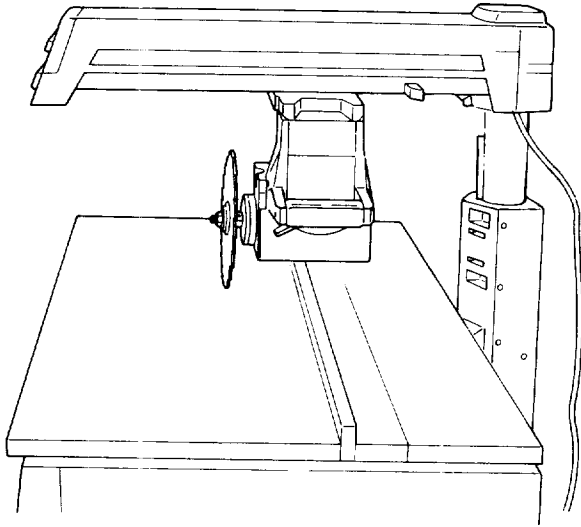

Fig. 87 - Out-rip Position

2. Lock *swivel lock* and *rip lock*.

3. Place the long edge of the framing square on the *table* and the short edge against the *blade* alongside the *arbor shaft*. Make sure the square is against the surface of the *blade* and not on the set of a tooth. (Figure 88)

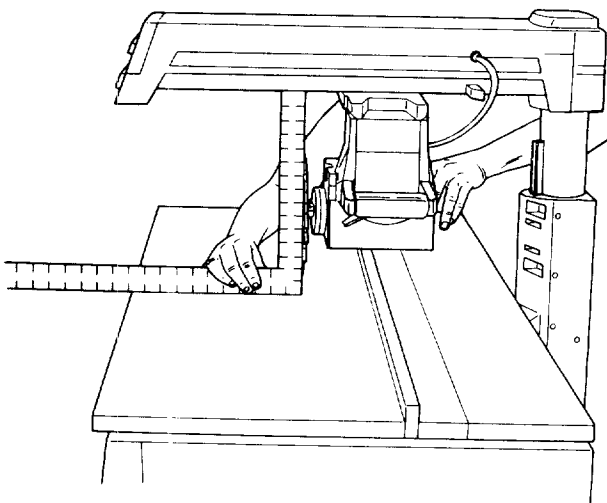

Fig. 88

4. Turn the *blade* with your hand several times and check to see if the square is flush with the *blade*.

5. If the square is flush with the *blade* after each rotation (Figure 89) go to step 11, or

If there is a gap between the square and the *blade* after any rotation (Figure 89), go to step 6.

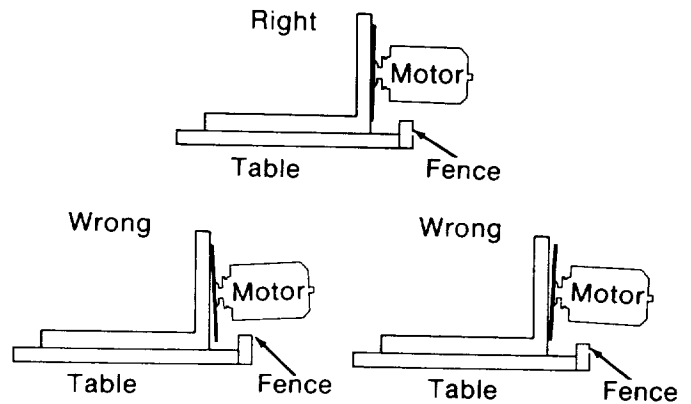

Fig. 89

6. Loosen the hex nut on the *rear carriage bearing*. Use a 9/16 inch wrench to hold the bolt and a 1/2 inch wrench to loosen the nut. (Figure 90)

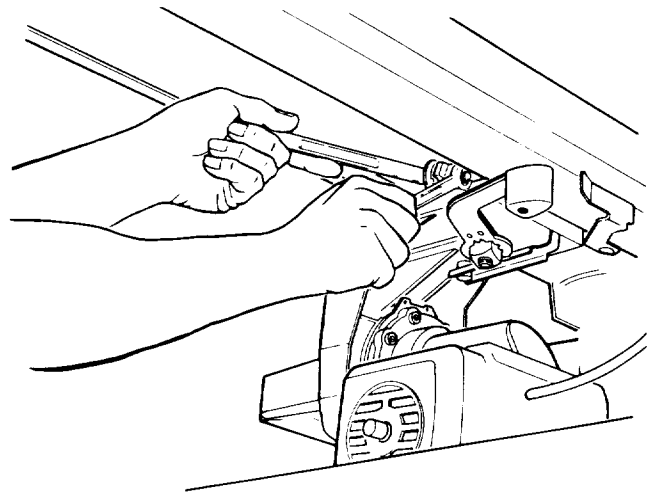

Fig. 90

7. Hold the square in place and use the 9/16 inch wrench to turn the bolt until the square is flush with the *blade*.

8. Hold the bolt firmly, and retighten the hex nut using a 1/2 inch wrench.

9. Turn the *blade* several times and check to see if the square is still flush with the *blade*.

10. If the square is flush with the blade after each rotation, go to step 11, or

If there is a gap between the square and the blade, go back to step 6 and repeat.

11. Unlock the *rip lock* and move the *motor* as far back as it will go.

12. Pinch the *front carriage bearing* with your fingers as tightly as possible while you pull the *motor* forward with the other hand. Try to keep the *carriage bearing* from turning. (Figure 91)

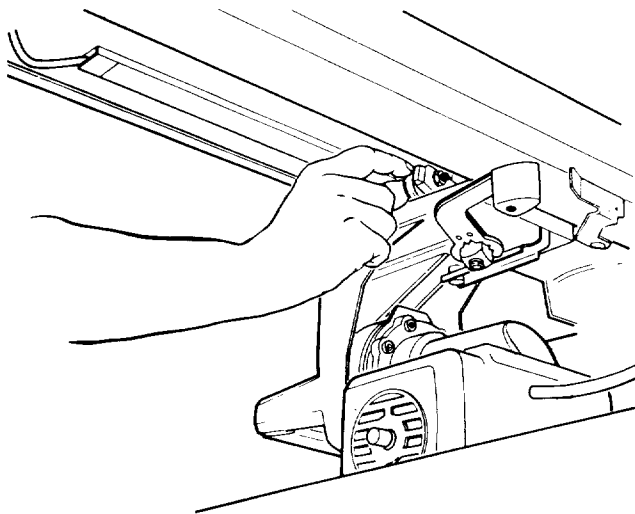

Fig. 91

13. Move the *motor* as far forward as it will go.

14. Pinch the *rear carriage bearing* with your fingers as tightly as possible while you pull the *motor* toward the rear with the other

hand. Try to keep the *carriage bearing* from turning.

15. If you can keep either of the *carriage bearings* from turning while the *motor* moves along the *radial arm*, go to step 16, or

If you cannot keep the *carriage bearings* from turning while the motor moves, go to step 22.

16. Wipe the V-shaped groove in each *carriage bearing*, and the track they ride on, with a cloth to remove sawdust and other debris. Oil if necessary.

17. Loosen the hex nut on the *carriage bearing* that was loose. Use a 9/16 inch wrench to hold the bolt and a 1/2 inch wrench to loosen the nut.

18. Turn the bolt using a 9/16 inch wrench until the looseness is gone.

19. Hold the bolt firmly with the 9/16 inch wrench and tighten the hex nut using a 1/2 inch wrench. Do not overtighten.

20. Adjust the other carriage bearing by the same amount so that the *blade* will still be square with the *table*.

21. Repeat steps 11-15 to make sure that the *carriage bearings* are not still loose.

22. Place the long edge of the framing square on the *table* and the short edge against the *blade* just above the *arbor shaft*, as before. Make sure the square is against the surface of the *blade* and not on the set of a tooth.

23. Turn the *blade* with your hand several times and check to see if the square is flush with the *blade*.

24. If the square is flush with the *blade*, go to the next section, or

If there is a gap between the square and the *blade*, go back to step 6 and repeat.

Making Blade Parallel to Table

These steps are done to help prevent the workpiece from being thrown or damaged when the saw is used for edging.

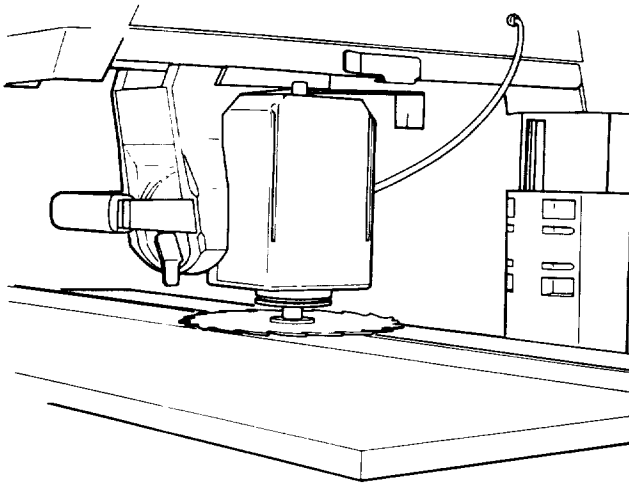

Fig. 93

1. Put the *radial arm* in the 0° miter position.
2. Raise the *radial arm* until the *blade* is 1-1/2 inches above the *front table*.
3. Unlock the *bevel lock*, and turn the *motor* so that the *blade* is parallel to the *table*. (Figure 93)

CAUTION: The motor is heavy and can swing down quickly. You can be cut or injured if the blade hits you. Hold the motor when you unlock the bevel lock.

4. Lock the *bevel lock*, *rip lock* and *swivel lock*.
5. Place the corner of the framing square against the *fence* so that the long edge is on the *table* under the *blade* and the short edge is sticking up in the air. Make sure that the long edge is perpendicular to the *fence*. (Figure 94)

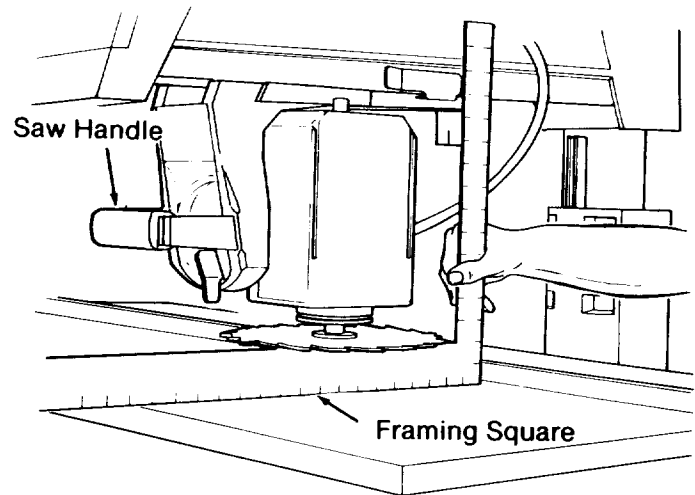

Fig. 94

6. Lower the *radial arm* until the *blade* just rests on the edge of the framing square. Make sure that the square is on the blade and not on the set of a tooth.

7. Turn the *blade* with your hand several times and check to see if the square is flush with the *blade*.

8. If the square is flush with the *blade* after each rotation (Figure 95) go to step 18, or

If there is a gap between the square and the *blade* after any rotation (Figure 95) go to step 9.

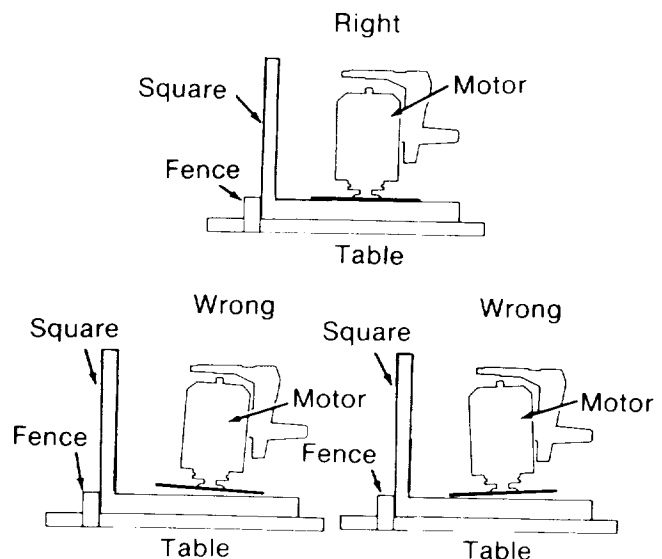

Fig. 95

9. Unlock the *bevel lock*.

10. Loosen the two screws on the back of the *motor support* using a 3/16 inch hex-L wrench and pliers if necessary. (Figure 96)

⚠ WARNING: The hex-L wrench may break when used with pliers to loosen screws. Thrown pieces could hit you in the face and/or eyes. Wear safety goggles when using a hex-L wrench with pliers.

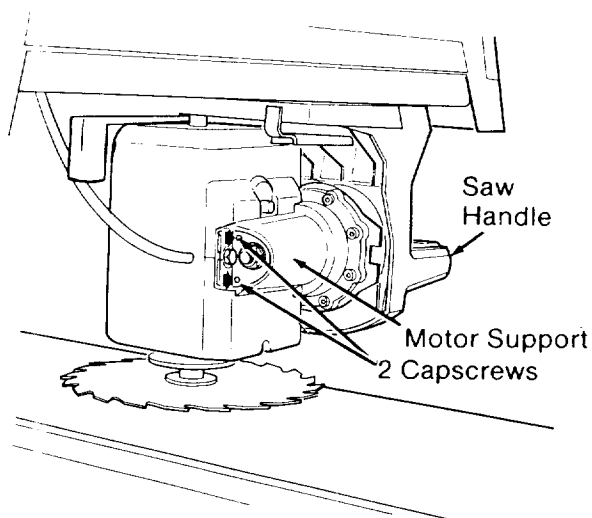

Fig. 96

11. Hold the square in place, and lift or lower the bottom side of the *motor support* until the square is flush with the *blade*.

12. Hold the *motor* firmly and lock the *bevel lock*.

13. Check the square to make sure that it is still flush with the *blade*.

14. Tighten the two screws on the back of the *motor support*.

15. Place the corner of the framing square against the *fence* so that the long edge is on the *table* under the *blade* and the short edge is sticking up in the air, as before. Make sure that the long edge is perpendicular to the *fence*.

16. Turn the *blade* with your hand several times and check to see if the square is flush with the *blade*.

17. If the square is flush with the blade after each rotation, go to step 18, or

If there is a gap between the square and the blade, go back to step 9 and repeat.

Installing Guard / Setting Spreader

The blade guard and the spreader are very important safety features of your saw. The guard covers a large part of the blade and reduces the risk of amputation. The spreader rides in the kerf of the cut wood during ripping, and helps keep the two sides from pinching the blade and causing a kickback.

⚠ WARNING: Fingers, hand, or arm can be cut off from blade contact if the blade guard is not used properly. Always put the blade guard on your saw and adjust it correctly.

⚠ WARNING: Kickback can occur if the spreader is not in line with the blade. You can be injured or killed. Always adjust the spreader and make sure that it is directly in line with the blade.

1. Loosen the *guard clamp screw* until it no longer touches the *metal plate*. (Figure 97)

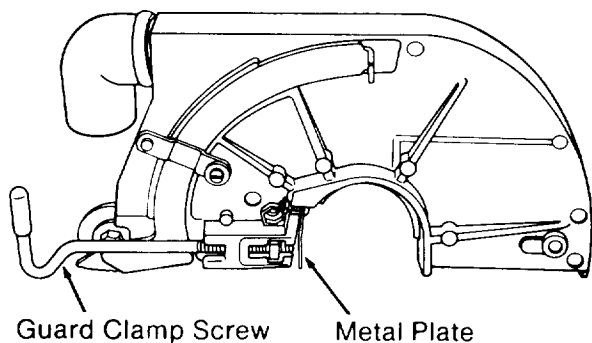

Fig. 97

2. Place the *guard* over the *blade*. You will feel the *guard* fall into place when the ridge on the inside of the *guard* slides into the slot on the *motor*. (Figure 98)

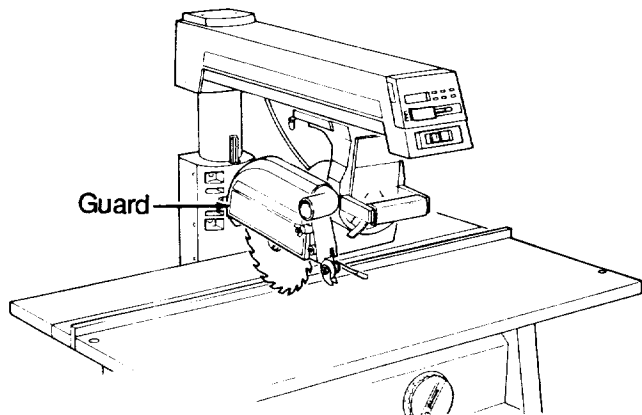

Fig. 98

3. Make sure that the lower edge of the *guard* is parallel to the table. (Figure 99 above)

4. Tighten the *guard clamp screw*.

5. Unlock the *swivel lock* and turn the *motor* to the in-rip position, with the *blade* between the *motor* and the *fence*. (Figure 99)

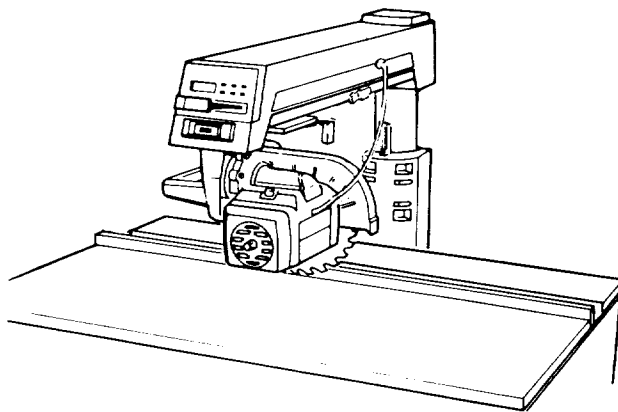

Fig. 99 - In-rip Position

6. Lock the *swivel lock*.

7. Lower the *radial arm* until the *blade* is just above the *table*.

8. Unlock the *rip lock* and move the *motor* back until the *blade* touches the *fence*.

9. Lock the *rip lock*.

10. Loosen the wing screw that holds the *spreader* in place.

11. Lower the *spreader* and *antikickback pawls* until the *spreader* is against the *fence*, and the *pawls* on one side of the *spreader* are on top of the *fence*. (Figure 100)

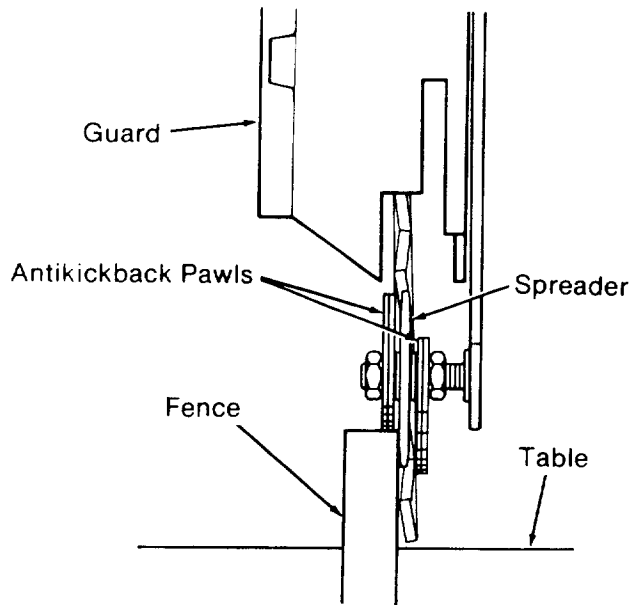

Fig. 100

12. If the *spreader* and *blade* both rest against the *fence*, no adjustment is needed. (Figure 101-A) Go to step 17, or

If the *spreader* is in front of the *fence* but not touching it (Figure 101-B), go to step 13, or

If the *spreader* hits the top of the *fence* (Figure 101-C), go to step 13.

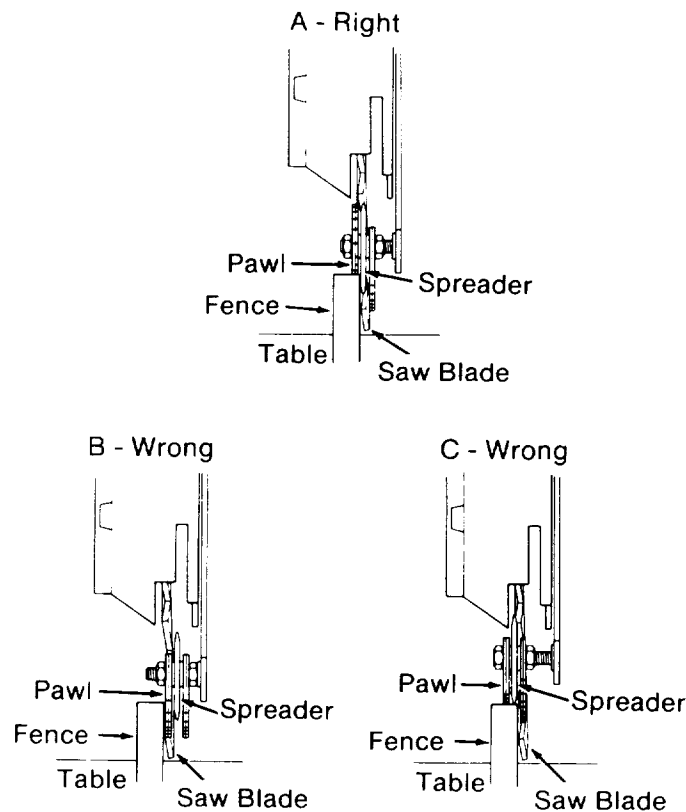

Fig. 101-A,B,C

13. Loosen both nuts on the *spreader* using a 1/2 inch wrench.

14. Slide the *spreader* with your hand until it is against the *fence* directly behind the *blade*.

15. Tighten both nuts using a 1/2 inch wrench. Do not move the *spreader* as you tighten these nuts.

16. Check the *blade* and *spreader* again to make sure that they are both against the *fence*. If not, go back to step 13 and repeat.

17. Once the *blade* and *spreader* are in line, raise the *spreader* up to the *guard* and tighten the wing screw to hold it in place.

18. Unlock the *rip lock*.

19. Pull the *motor* forward so that the *blade* is away from the *fence* and lock the *rip lock*.

20. Unlock the *swivel lock*.

21. Turn the *motor* to the crosscut position with the blade and arm perpendicular to the fence.

22. Lock the *swivel lock*.

Digital Display

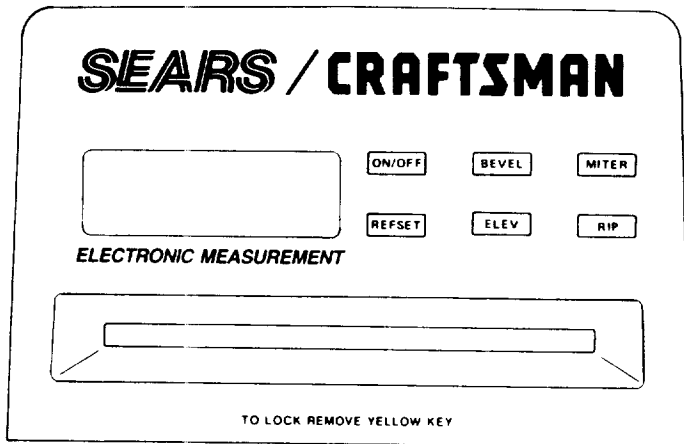

Fig. 102 - Digital Display

Your radial arm saw has a digital display which tells you the position of the blade and arm at the touch of a button. This display helps you position the blade so that your cuts will be accurate.

The following buttons control the digital display:

ON/OFF : This button turns the display on and off. The display runs on battery power, and shuts itself off when no changes in blade or arm position have been made for three minutes. The system continues to track the location of the blade and arm when the display is turned off, and the current position may be displayed at any time.

REF SET: This button is used to set the "0" reference points for the digital display.

BEVEL : This button displays the bevel angle. The "0" display is usually set with the blade perpendicular to the table. A positive display shows the angle the blade has been turned counterclockwise. A negative display shows the angle the blade has been turned clockwise.

ELEV: This button displays the height of the blade. The "0" display is usually set with the blade just touching the table. A positive display shows the distance the blade has been raised above "0". A negative display shows the distance the blade has been lowered below "0".

MITER: This button displays the miter angle. The "0" display is usually set with the arm perpendicular to the fence. A positive display shows the angle the arm has been moved to the right. A negative display shows the angle the arm has been moved to the left.

RIP: This button displays the distance from the fence to the blade in the in-rip and out-rip positions. The "0" display for in-rip is usually set with the blade just touching the fence. The "10.00" display for out-rip is usually set with the blade ten inches from the fence.

The "0" reference points you set will be stored in the memory at all times, whether the display is turned on or off. If an error occurs you will see:

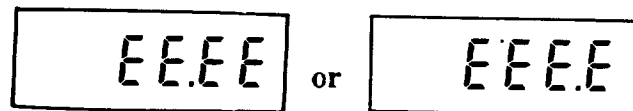

on the display. If this happens, you will need to reset the "0" reference point for the function displaying the error.

If the battery is very weak or dead the display will become faded and hard to read. If this happens, you will need to replace the battery and reset the "0" reference points for all functions.

Installing the Battery

1. Slide the *battery* into the opening behind the digital display with the angled corner on top. (Figure 103)

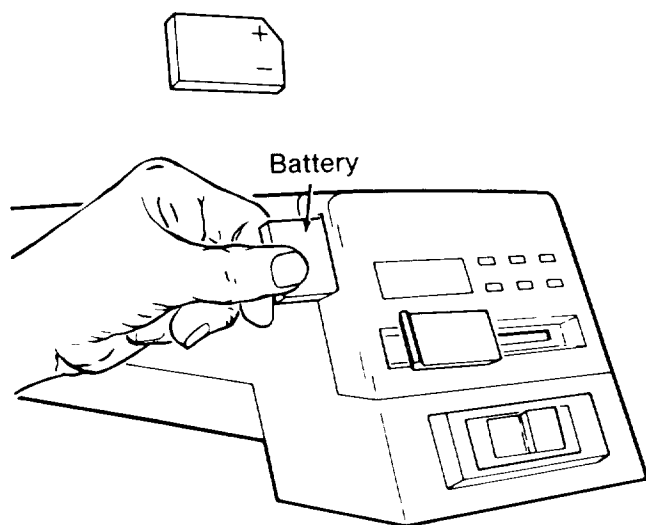
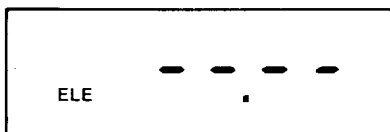

Fig. 103 - Installing the Battery

2. Push the *battery* all the way into this space and slightly downward. It will snap into place, and be held there by a *tab*.

3. If the display says:



a second or two after the *battery* is put in place, go to step 6, or

If the display does not show anything, go to step 4.

4. Remove the *battery*. Put it back in and check the display again, or

Remove the *battery*. Wipe off the battery contacts. Put the *battery* back in and check the display again, or

Remove the *battery*. Replace it with a new one. Check the display again.

5. If there is still no display, contact your nearest Sears store, or

If the display says:

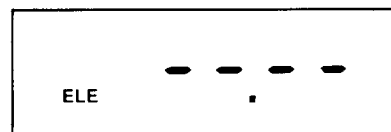

go to step 6.

6. Snap the *battery cover* into place.

7. Push the *ON/OFF button* to turn off the display.

Replacing the Battery

1. Use a screwdriver to pry the *battery cover* off.

2. Push in and slightly upward on the *battery*, then pull out. The *battery* is held in place by a tab that is released when you push in.

3. Replace the *battery* with a 6V, alkaline battery by following the Installing the Battery section.

Aligning Encoders

Miter Encoder

1. Push the *ON/OFF button* to turn the display on.

2. Put the saw in the crosscut position with the *radial arm* perpendicular to the *fence*.

3. Lock the *miter lock*.

4. Push the *MITER button*.

5. Push the *REF SET button*. The display will say:

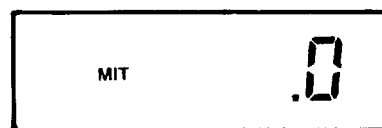

6. Unlock the *miter lock*.

7. Move the *arm* to the right until it snaps into the 45° position.

8. Lock the *miter lock*.

9. The display should say:

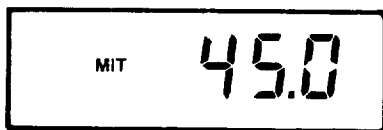

10. Unlock the *miter lock*.

11. Move the *arm* to the left until it snaps into the -45° position.

12. Lock the *miter lock*.

13. The display should say:

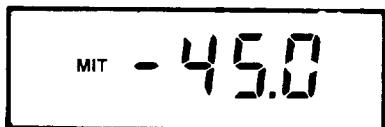

14. If the display is correct at all three points, go to the next section, or

If the display is not correct at one or more of these points, go to step 15.

15. Unscrew the two mounting screws on the back of the *arm* and take off the *rear arm cover*.

16. Unlock the *miter lock*.

17. Move the *arm* to the right until it snaps into the 45° miter position.

18. Lock the *miter lock*.

19. Loosen the mounting screws on the *miter encoder* until the *encoder* will slide to the right and left. (Figure 104)

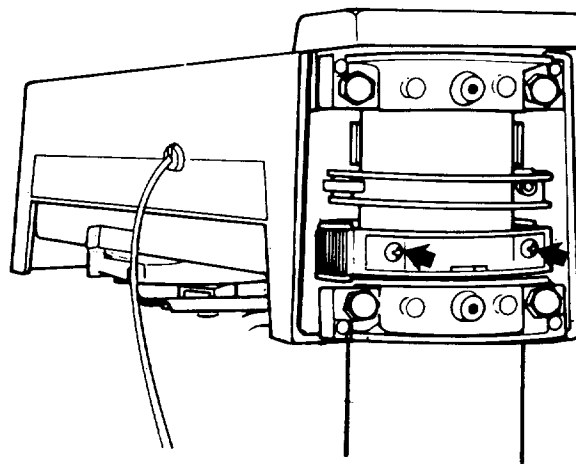
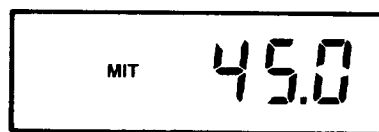

Fig. 104 - Screws for Miter Encoder

20. Slide the *encoder* slightly until the digital display says:



You may need to tap on the *encoder* to move it, but do not force it or hit it hard.

21. Tighten the mounting screws on the *encoder*.

22. Repeat steps 2-13 to make sure you did not move the *encoder* when tightening the mounting screws.

23. If the display is still not correct repeat steps 16 - 22 until the *miter encoder* is in the right position, or

If the display is correct, put the *rear arm cover* back on the *radial arm*. Go to the next section.

Bevel Encoder

1. Push the *ON/OFF* button to turn the display on.
2. Put the saw in the crosscut position with the *radial arm* perpendicular to the *fence* and the *blade* perpendicular to the *table*.
3. Lock the *bevel lock*.
4. Push the *BEVEL* button.
5. Push the *REF SET* button. The display will say:



6. Unlock the *bevel lock*.
7. Turn the *motor* to the 45° bevel position.

⚠ CAUTION: The motor is heavy and can swing down quickly. You can be cut or injured if the blade hits you. Hold the motor when you unlock the bevel lock.

8. Lock the *bevel lock*.
9. The display should say:

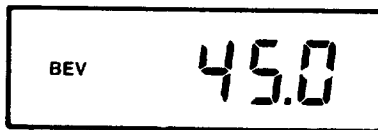

10. Unlock the *bevel lock*.
11. Move the *motor* to the 90° bevel position.
12. Lock the *bevel lock*.
13. The display should say:

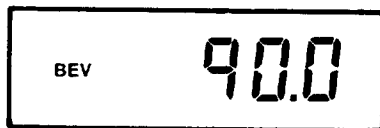

14. If the display is correct at all three points, go to the next section, or

If the display is not correct at one or more of these points, go to step 15.

15. Unlock the *bevel lock*.
16. Move the *motor* to the 45° bevel position.
17. Lock the *bevel lock*.
18. Loosen the two aligning screws on the *bevel encoder* until the *encoder* will slide from right to left. (Figure 105)

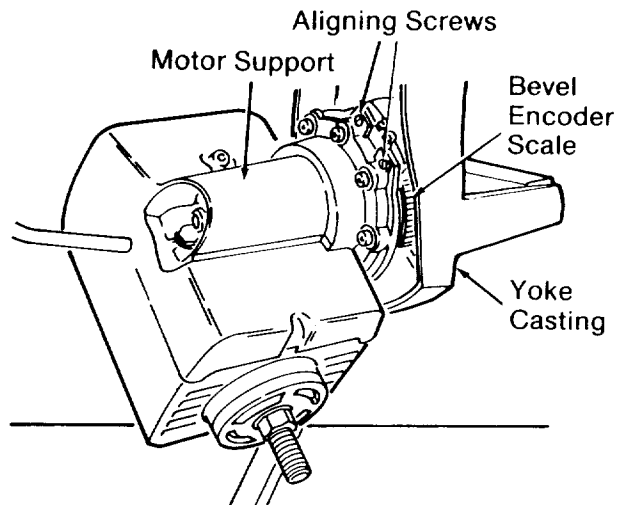
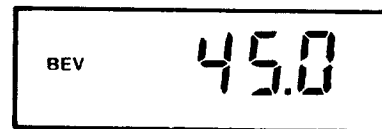

Fig. 105 - Screws for Bevel Encoder

19. Slide the *encoder* slightly until the display says:



You may need to tap on the *encoder* to move it, but do not force it or hit it hard.

20. Tighten the two aligning screws on the *encoder*.
21. Repeat steps 2 - 13 to make sure you did not move the *encoder* when tightening the two screws.

22. If the display is still not correct, repeat steps 15 - 21 until the *bevel encoder* is in the right position, or

If the display is correct, go to the next section.

Setting Zero References

Bevel, Miter and Elevation

The "0" reference points for miter, bevel, and elevation are usually set with the:

- Saw in the crosscut position with the *radial arm* perpendicular to the *fence* (0° miter).
- Blade perpendicular to the *fence* and *front table* (0° bevel).
- Blade in front of the *fence* just touching the *front table* (0 inches elevation).

You may set the "0" reference points in this position, or any other position you choose.

1. Put the *blade* in the position you have chosen to be the zero reference point.
2. Push the *MITER* button.
3. Push the *REF SET* button.
4. The display will say:



5. Push the *BEVEL* button.
6. Push the *REF SET* button.
7. The display will say:

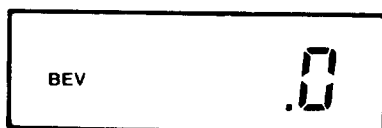

8. Push the *ELEV* button.

9. Push the *REF SET* button.

10. The display will say:

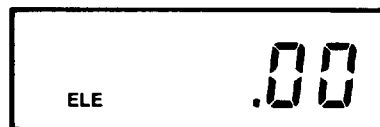

In-rip Reference

The "0" reference point for in-rip is usually set with the blade just touching the front of the fence.

1. Unlock the *swivel lock*.
 2. Turn the *motor* to the in-rip position with the *blade* between the *motor* and the *fence*.
 3. Lock the *swivel lock*.
 4. Unlock the *table locks* and put the fence between the *front table* and the *spacer*.
 5. Lock the *table locks*.
 6. Unlock the *rip lock*.
 7. Move the *motor* back until the *blade* is just touching the front of the *fence*.
 8. Lock the *rip lock*.
 9. Push the *RIP* button.
 10. If the display shows the RIP function, go to step 11, or
- If the display shows the O-RIP function, push the *RIP* button again. Then go to step 11.
11. Push the *REF SET* button.
 12. If the display says:

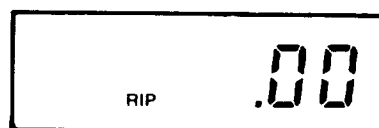

go to the next section, or

If the display says:



push the *REF SET* button again. Then go to the next section.

Out-rip Reference

The "0" reference point for out-rip is usually set with the blade ten inches from the fence.

1. Unlock the *swivel lock*.
2. Turn the *motor* to the out-rip position with the *motor* between the *blade* and the *fence*.
3. Lock the *swivel lock*.
4. Unlock the *table locks* and move the *fence* behind the *spacer* and *rear table*. (Figure 119)
5. Lock the *table locks*.
6. Unlock the *rip lock*.
7. Move the *motor* until the *blade* is 10 inches in front of the *fence*. Use a framing square, ruler or tape measure to measure this distance. (Figure 106)

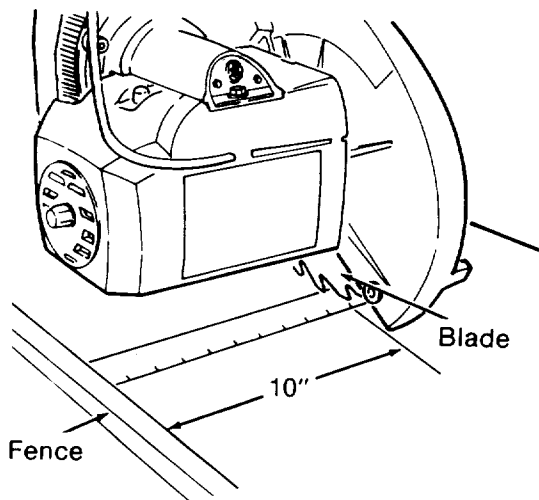

Fig. 106 - Out-Rip Reference

8. Lock the *rip lock*.

9. Push the RIP button.

10. If the display shows the O-RIP function, go to step 11, or

If the display shows the RIP function, push the RIP button again. Then go to step 11.

11. Push the *REF SET* button.

12. If the display says:



13. Push the *REF SET* button again.

The display will say:



Electrical Connections

Motor Specifications

The AC motor used in this saw is a capacitor-start, non-reversible type having the following specifications:

Rated H.P.	1.5
Maximum Developed H.P.	2.5
Voltage	120
Amperes	11
Hertz (cycles)	60
Phase	Single
RPM	3450
Rotation of Arbor Shaft	Clockwise

Power Supply

⚠ WARNING: Your saw is wired at the factory for 120V operation. Connect to a 120V, 15-AMP, branch circuit and use a 15-AMP, time delay fuse or circuit breaker. Failure to connect in this way can result in injury from shock or fire.

Your saw must be properly grounded. Not all outlets are properly grounded. If you are not sure that your outlet is properly grounded, have it checked by a qualified electrician.

⚠ WARNING: If not properly grounded this power tool can cause electrical shock, particularly when used in damp locations.

⚠ WARNING: If an electrical shock occurs, your reaction to the shock may bring your hands into contact with the blade.

⚠ WARNING: To avoid shock or fire, if power cord is worn, cut, or damaged in any way have it replaced immediately.

Your unit is wired for 120V, it has a plug that looks like the one shown below. (Figure 107)

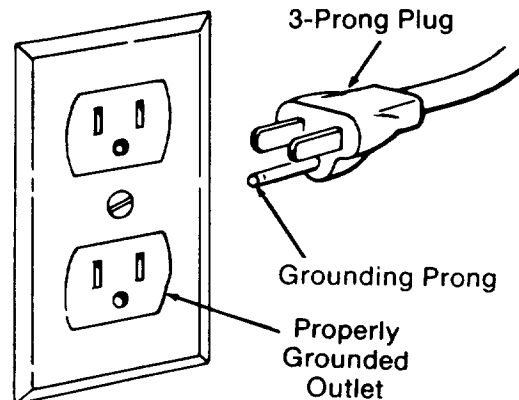

Fig. 107 - Plug for Less Than 150V

This power tool is equipped with a 3-conductor cord and grounding type plug listed by Underwriters' Laboratories. The ground conductor has a green jacket and is attached to the tool housing at one end and to the ground prong in the attachment plug at the other end.

This plug requires a mating 3-conductor grounded type outlet as shown above. If you have an outlet that is of the two prong type, it is recommended that you have a qualified electrician replace it with a properly grounded three prong outlet.

⚠ WARNING: To maintain proper tool grounding, whenever the outlet you are planning to use for this power tool is of the two prong type do not remove or alter the grounding prong in any manner.

An adapter is available for connecting plug to 2-prong receptacles. The green grounding lead extending from the adapter must be connected to a permanent ground such as to a properly grounded outlet box. (Figure 108)

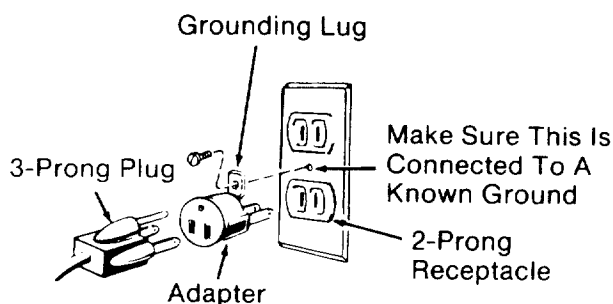

Fig. 108 - Adapter for 2-Prong Receptacles

⚠ WARNING: The adapter illustrated is for use only if you already have a properly grounded 2-prong receptacle.

Extension Cords

The use of any extension cord will cause some loss of power. Use the following table to determine the minimum wire size (A.W.G.) extension cord. Use only 3-wire extension cords which have 3-prong grounding type plugs and 3-pole receptacles which accept the tool's plug.

Length of Conductor	Wire sizes Required (American Wire Gage No.) 120V Lines
0 - 25 feet	No.14
26 - 50 feet	No.12
51 - 100 feet	No. 8

For circuits that are farther away from electrical circuit box, the wire size must be increased proportionately in order to deliver ample voltage to the saw motor.

Crosscutting

Crosscutting is used to cut a workpiece to length. The workpiece is held against the fence. The saw blade is pulled through the workpiece. Cuts are usually made across the grain of the workpiece.

Types of Crosscuts

The basic types of crosscuts are shown below. Notice the hand and body position in each.

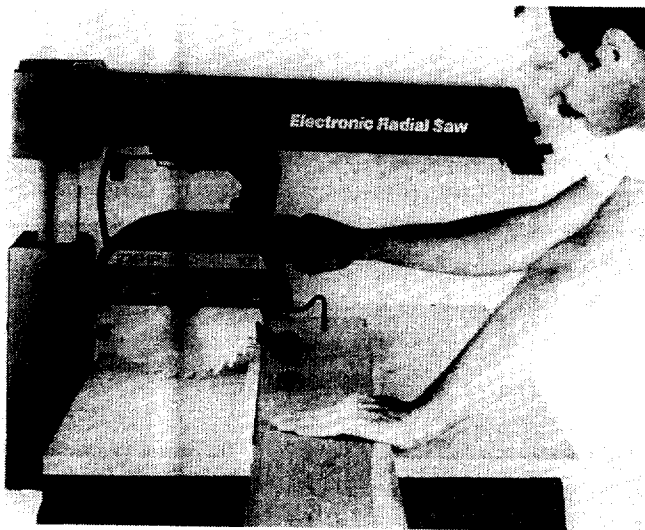

Fig. 109 - Straight Crosscut



Fig. 110 - Miter Crosscut

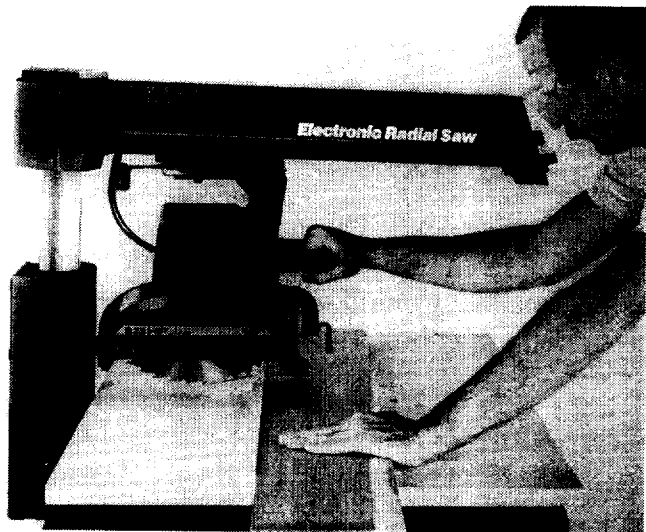

Fig. 111 - Bevel Crosscut

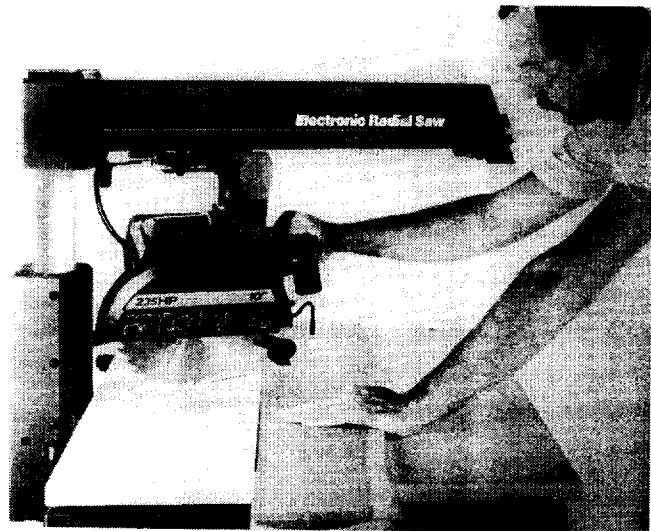

Fig. 112 - Compound Crosscut

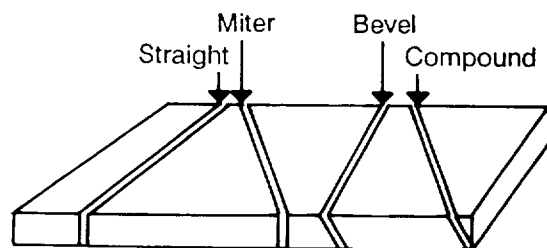

Fig. 113 - Basic Crosscuts

Safety Information for Crosscutting

Read and follow the safety information below before making any type of crosscut.

WARNING

1. Set guard and anti-kickback pawls to proper height to serve as a partial barrier.

2. The saw blade can throw the workpiece over the fence if the blade is pushed backwards into workpiece. You or others can be hit and injured by the thrown workpiece. Start a crosscut with the blade in its rearmost position.

3. If the blade is pulled through the workpiece beyond the middle of the blade, it can:

- pick up and throw the cut-off section of the workpiece which could hit and injure you or others in the area, or;
- lift or move the held-down section of the workpiece and pull your hand into the blade as the blade is returned. Pull the saw blade through the workpiece to the distance shown below.

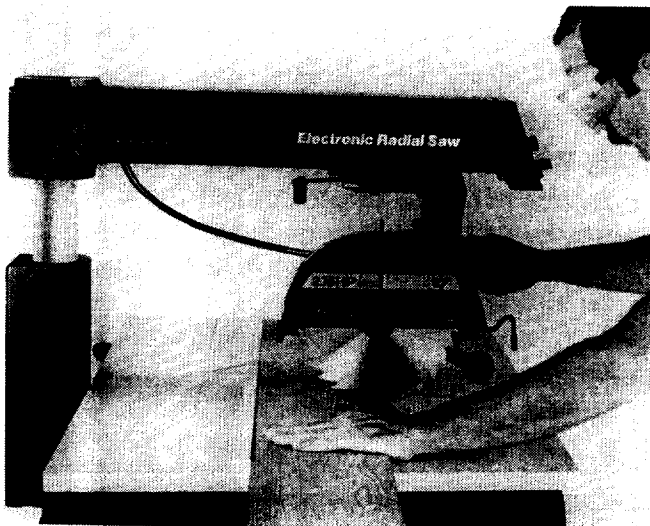

Fig. 114 - Blade Distance to Complete Crosscut

4. Fingers or hand can slip into the saw blade as you make a crosscut. Fingers, hand or arm can be cut off. Keep the hand holding the workpiece at least 8 inches to the side of the workpiece, out of the path of the saw blade. Keep hand holding the workpiece in view at all times.

5. The blade can come completely off table edge beyond the 30° left miter position. Fingers, hands, arms or legs can be cut off. Use the right miter position whenever possible to make miter crosscuts.

6. The blade continues to turn for about 12 seconds after the saw is turned off. Wait for the blade to stop before reaching for the workpiece.

7. If length stops are used on the cut-off end of workpiece, the cut-off end can be thrown by the blade. The workpiece could hit and injure you or others in the area. Do not use a length stop on the cut-off end of the workpiece. Use a length stop only on the end of the workpiece which is held down.

8. Holding on to or touching the cut off end of the workpiece while the saw blade is still turning can cause the workpiece to pinch the blade. The workpiece can be thrown and hit and injure you or others in the area. Do not touch, hold on to, push, or grab the cut-off piece of the workpiece while the power is on or the saw blade is turning.

9. The saw can throw the workpiece, workpiece chips or pieces of the blade violently. You can be blinded. Wear safety goggles.

10. The workpiece cannot be controlled or held stable enough to do free hand cutting. The workpiece can be thrown or slip and pull fingers and hand into the saw blade. Fingers or hand can be cut off. Set the radial arm to the desired cutting angle. Keep workpiece flat on table and solidly against the fence.

11. Saw parts loosen and wear with use. You or others can be injured. Keep all parts tight and in working order.

12. The fence must be of at least equal height to the workpiece or else the workpiece can be lifted or thrown and hit and injure you or others in the area. See Cutting Accessories section for instructions to make a fence.

13. The blade will try to pull itself through the workpiece. Be prepared to hold the saw handle back to keep the saw blade from coming toward you.

14. Lock rip lock after every crosscut, or else the blade will suddenly come toward you when you lower it to make a crosscut.

15. Whenever the blade is turning, keep one hand on the saw handle to keep the saw blade from coming toward you.

16. Cutting more than one workpiece at a time can cause you to lose control of the workpieces, which can be thrown and hit and injure you or others in the area. Cut only one workpiece at a time. Do not stack or lay workpieces edge to edge.

Blade Guard, Anti-Kickback Pawls and Spreader

The blade guard, anti-kickback pawls and spreader are designed to reduce or eliminate the risk of injury from contact with the upper half of the blade and the leading edge of the blade when:

- the guard is in the horizontal position and;
- the pawls and spreader are set to clear the top of the fence and workpiece by about 1/8 inch.

The Blade Guard:

- provides protection from contact with the upper half of the blade;
- helps keep the workpiece from jamming in the guard and;
- helps catch or deflect workpiece chips or pieces of the blade.

The Anti-kickback Bar, Pawls and Spreader:

- serve as a partial barrier to provide protection from contact with the leading edge of the blade.

 **WARNING:** To reduce the risk of contact with the upper half of the blade and keep the workpiece from jamming in the guard, set the blade guard in the horizontal position, Fig. 118.

Crosscutting Checklist

Use the following checklist at the beginning of each new cutting period to reduce the risk of an accident.

Crosscut Checklist

Yellow key removed from red switch.

Saw unplugged and switch off.

No play in the carriage bearings, motor support or column. See Alignment of the Blade section for instructions.

Arm slopes to the rear and table level side to side.

Arbor nut snug.

Blade sharp .

Fence secure, solid (knot free) and in good condition.

Fence in correct table position.

Workpiece does not extend above the top of the fence.

All saw parts are tight and working.

Saw blade in desired crosscut position and behind the fence.

Blade guard horizontal.

Anti-kickback pawls and spreader set to clear top of fence and/ or workpiece by about 1/8 inch.

Swivel, rip, miter, bevel and table locks locked.

Read and follow instructions for the type of crosscut you want to do.

Cutting Table and Fence Kerfs

You will need to cut a new table kerf (shallow cut) and fence kerf (slot left in the fence from sawing through it with the blade), each time a new cutting angle is used. The table kerf lets the blade cut all the way through a workpiece.

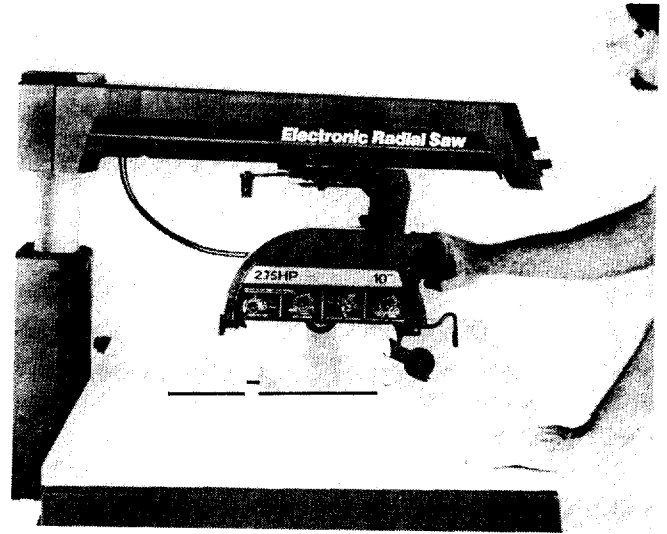

Fig. 115 - Table and Fence Kerfs

Note: To extend the life of your table top, you can make an additional table top. See Helpful Hints section.

Making Table and Fence Kerfs for Crosscutting

To make a crosscut kerf in your table and fence:

1. Put your fence between the front table and spacer board. Lock the table locks.
2. Push the saw to the rearmost position, behind the fence.
3. Lock rip lock.

⚠ WARNING: The saw blade will suddenly come toward you when lowered into the table if the rip lock is unlocked. Fingers and hand can be cut off. Lock the rip lock before and after each crosscut.

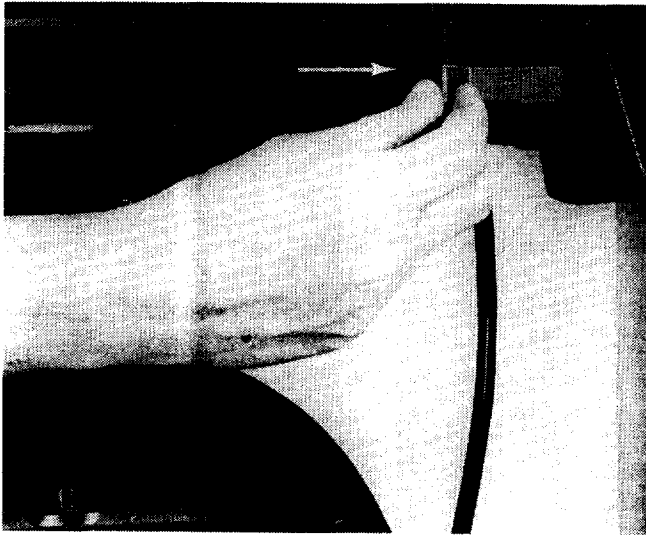

Fig. 116 - Locked Position for Rip Lock

4. Lower the radial arm until the blade almost touches the table top.

5. Plug the saw into a grounded outlet. Check Electrical Connections section of manual if you are not sure the outlet is grounded.

6. Wear safety goggles labeled ANSI Z87.1 on the package.

⚠ WARNING: The saw can throw the workpiece, workpiece chips or pieces of the blade violently. You can be blinded. Wear safety goggles.

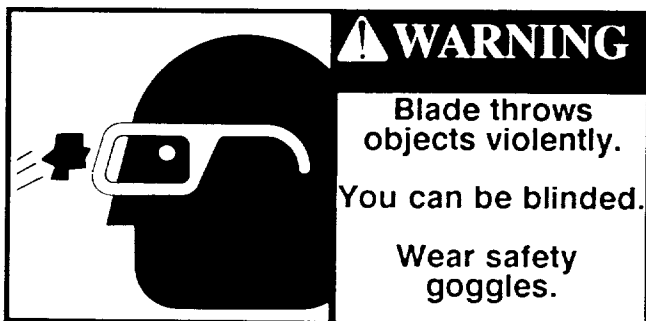

Fig. 117 - Safety Goggles Safety Sign

7. Insert yellow key into the red switch.

8. Grasp saw handle and hold your forearm in line with the saw handle as shown below.

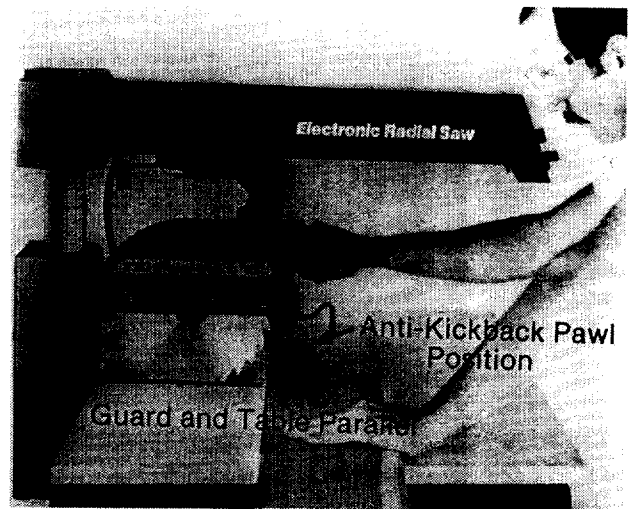

Fig. 118 - Crosscut Blade Guard and Body Position

⚠ WARNING: Saw blade can suddenly come toward you when turned on. Fingers, hand or arm can be cut off. Keep one hand on the saw handle at all times.

9. Turn the saw on.

10. Lower the saw arm slowly until the blade touches the table.

11. Turn the handwheel another 1/2 turn more. This will let you make a 1/32 to 1/16 inch kerf in the table.

12. Unlock rip lock.

13. Pull the saw blade forward through the fence and along the table as far as it will go.

14. Return the saw blade to its rearmost position behind the fence.

15. Turn the saw off, but do not let go of the saw handle.

16. Wait for blade to stop turning.

17. Lock rip lock.

18. Remove yellow key from red switch.

Making Crosscuts

The following section contains safety information and instructions for making crosscuts. Anyone who uses your saw should read and follow these steps.

⚠ WARNING: The blade guard must be horizontal to provide protection from contact with the upper half of the blade and avoid the workpiece being jammed in the blade. Set the blade guard in the horizontal position. Fig. 118.

⚠ DANGER: The anti-kickback pawls serve as a barrier for the leading edge or the blade. Set the anti-kickback pawls to clear the top of the fence and workpiece by about 1/8 inch.

⚠ WARNING: The fence must be at least equal height or higher than the workpiece you are going to cut or else the workpiece can be thrown and injure you or others in the area. Install a fence of at least equal height to the workpiece.

1. Put your fence in position A as shown and lock the table locks.

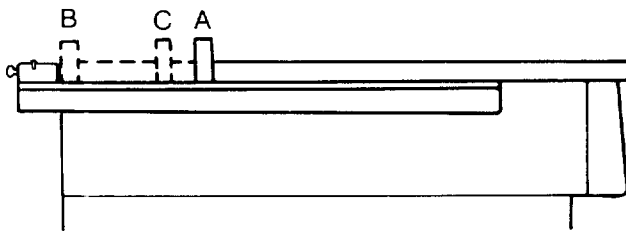

Fig. 119 - Fence Position for Crosscut

2. Push the saw to the rearmost position, behind the fence.

3. Lower the blade into but not touching the table kerf.

4. Adjust the height of the anti-kickback pawls to clear top of fence and workpiece by about 1/8 inch. The pawls and spreader help provide protection from the leading edge of blade.

5. Plug saw into grounded outlet.

6. Put on safety goggles.

7. Place the workpiece against the fence.

8. Unlock rip lock.

9. Grasp the saw handle while holding your forearm in a straight line with the saw handle.

⚠ WARNING: The saw blade tries to pull itself through the workpiece. Be prepared to hold saw handle back to keep the saw blade from coming toward you. Keep one hand on the saw handle at all times.

⚠ WARNING: If the saw blade is pulled through the workpiece beyond the middle of the saw blade, it can:

- pick up and throw the cut-off section of the workpiece which could hit and injure you or others in the area, or;
- lift or move the held-down section of the workpiece and draw your hand into the blade as the blade is returned.

Pull the saw blade through the workpiece to the distance shown below.



Fig. 120 - Distance Needed to Complete Crosscut

10. Insert yellow key into red switch.

11. Turn saw on.

⚠ WARNING: Saw blade can be pulled into or over fingers or hand. Fingers or hand can be cut off. Keep hand holding the workpiece at least 8 inches to the left of, and out of the path of the saw blade. Keep hand in view at all times.



Fig. 121 - Hand Placement for Crosscuts

12. Support and hold the workpiece down and against the fence firmly with your left hand.

13. Pull blade through fence and workpiece just enough to complete the cut. (Fig. 120)

14. Return saw to its rearmost position and continue to hold the saw handle.

15. Turn saw off.

16. Wait for the blade to stop turning.

17. Remove yellow key from red switch.

Repetitive Crosscuts

To make repetitive crosscuts:

1. Use two pieces of 1 inch by 2 by 2 inch lumber.

2. Use a C clamp to clamp one piece on each side of the lower right edge of the radial arm.

3. Clamp pieces of lumber at the distance necessary to complete the crosscut.

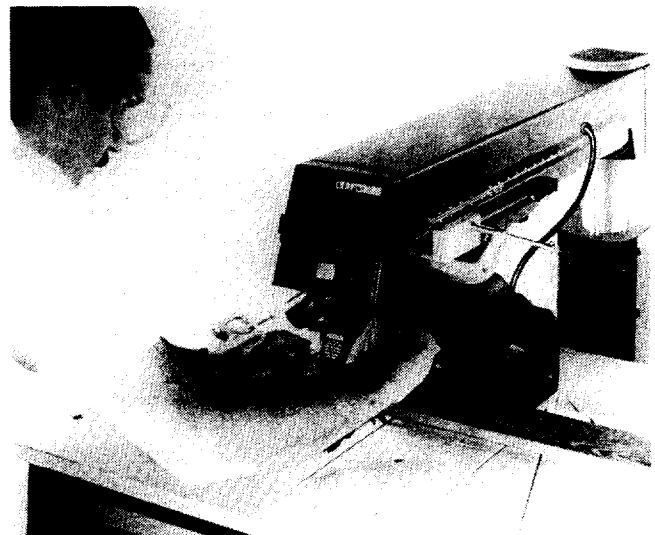

Fig. 122

Ripping

Ripping is used to change the width of the workpiece by sawing along its length. The workpiece is fed into the saw blade. The fence is used as a guide. Rip cuts are usually made with the grain of the workpiece.

Saw Positions for Ripping

There are two saw blade positions for making rip cuts: in-rip and out-rip.

In in-rip position, motor is toward the front of the table, and blade is toward the fence.

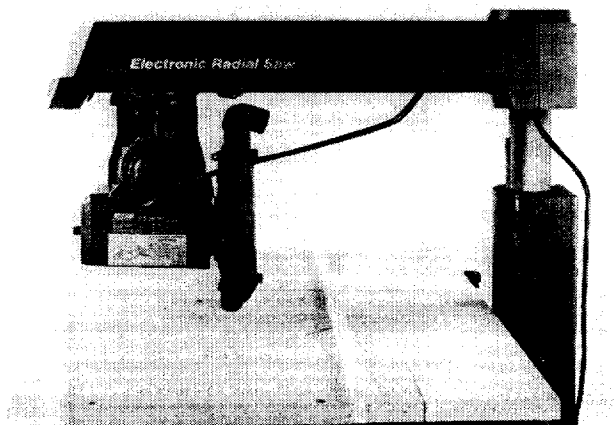

Fig. 123 - In-Rip Saw Position

In out-rip position, motor is toward fence and the blade is toward the front of the table.

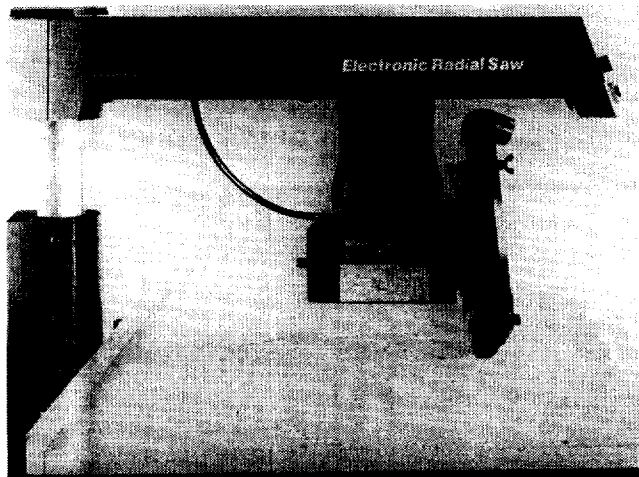

Fig. 124 - Out-Rip Saw Position (Infeed End)

⚠ WARNING: Stand only at infeed end of saw. Feed workpiece only into infeed end of saw as shown above.

When to Use In-Rip or Out-Rip

The in-rip saw position provides better visibility of both the workpiece and your hands than does the out-rip saw position. The only time you should use the out-rip saw position is when the workpiece is 14 inches or wider. Use the in-rip position for all workpieces less than 14 inches wide.

Workpiece Positioning for Ripping

Always set up the saw blade so the widest part of the workpiece is between the blade and the fence. For example, if you want to take 1 inch off an 11 inch wide workpiece, set the saw blade 10 inches from the fence. Do not rip 1 inch off an 11 inch workpiece by setting the saw blade 1 inch from the fence.

⚠ WARNING: If the blade is set between 2 inches and 6 inches from the fence, hands will be brought too close to the blade. Fingers and hand can be cut off. Use a push stick.

For example, if the workpiece is 7 inches wide and you want to cut 1 inch off the workpiece, place the saw blade 6 inches from the fence and use a push stick. Use a push stick when the distance between the saw blade and fence is between 2 inches and 6 inches. See Cutting Accessories section on how to make and use a push stick.

⚠ WARNING: If the blade is set between 1/2 inch and 2 inches from the fence, hands will be brought too close to the blade. Fingers/hand can be cut off. Use an auxiliary fence/push block.

For example, if the workpiece is 3 inches wide and you want to cut 1 inch off the workpiece, place the saw blade 2 inches from the fence and use a push block and auxiliary fence. See Cutting Accessories section.

Safety Information for Ripping

Read and follow the safety information below before making any type of rip cut.

DANGER

1. Kickback can happen when the saw blade is pinched or bound by the workpiece. This creates force in the opposite direction to which the workpiece is being fed. The teeth of the blade grab and throw the workpiece violently back out of the saw.

Kickback can happen when:

Anti-kickback pawls/spreader are not used or not correctly adjusted.

Spreader is not in line with the blade.

Blade is not parallel to the rip fence.

Edge of workpiece is not in contact with the rip fence or not straight.

Workpiece is twisted or warped and rocks on the table top.

Edge of workpiece is not completely against the rip fence, leaving gaps between the fence and workpiece edge.

Workpiece is released before being pushed completely past the saw blade.

Feeding pressure is put on the section of the workpiece farthest from the fence.

2. One of the most common and the most dangerous mistakes people make is to reach for the workpiece at the out-feed side of the saw. **DON'T !** The workpiece could kickback as you reach for, touch or try to pull the workpiece through the blade. You can lose your fingers, hand, or arm. The blade guard does NOT provide complete protection at outfeed end of the saw. Do not reach for the workpiece at outfeed end of the saw. Fingers, hand or arm can be cut off. Follow instructions for ripping.



Fig. 125 - Kickback, Blade Contact Safety Sign

3. The workpiece can also kickback violently toward you during a rip cut. You can be hit hard enough to cause broken bones and/or internal injury. Keep blade guard, anti-kickback pawls and spreader in place and adjusted. Apply feed pressure to the section of the workpiece next to the fence. Do not apply feed pressure on the section of the workpiece away from the fence. Stand out of the path of the workpiece.

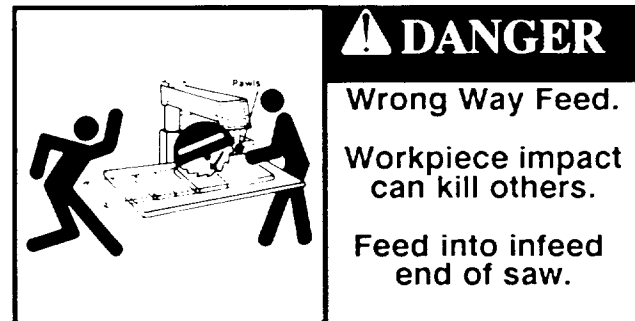

Fig. 126 - Kickback, Thrown Workpiece Safety Sign

4. Non-thru cuts increase the chance of kickback because the anti-kickback pawls cannot always grab the irregular workpiece surface. Use a featherboard. See Cutting Accessories section on how to make and use a featherboard.

5. The workpiece can snag or hang up on a fence with a kerf in it. The workpiece can be thrown or pinch the blade, causing kickback. Use solid fences when making rip cuts.

6. Wood cut with the grain can spring the kerf closed, bind the blade, and cause a kickback. Adjust spreader to ride in the kerf and prevent the kerf from closing on saw blade.

7. Composition materials, like particle boards and plastics, may be cut on the saw. Because these materials often have a harder and more slippery surface than wood, the anti-kickback pawls may not stop a kickback. Place finished side of workpiece down, roughest side of workpiece up. Make anti-kickback pawls and spreader adjustments. Stand out of the path of workpiece.

2. The workpiece can be grabbed by the saw blade and take off like a missile. Anyone standing in the path of the workpiece can be killed.

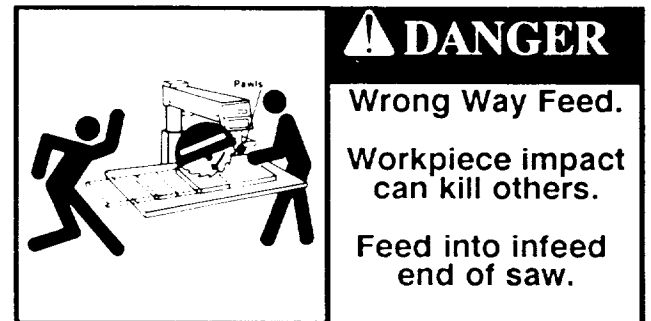
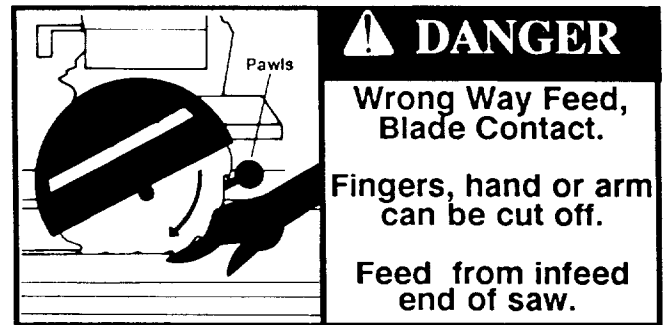

Fig. 127 - Wrong Way Feed Safety Signs

⚠ DANGER: Wrong Way Feed

Wrong way feed is feeding the workpiece into the end of the blade with pawls, the outfeed end. (Fig. 128) There are two things that can happen if you feed the workpiece into the outfeed end of the saw blade:

1. The workpiece can be grabbed by the blade and pull your hands into the blade before you can let go or pull back. Fingers, hands or arms can be cut off.



Fig. 128 - Infeed and Outfeed Ends of Saw Blade

Blade Guard, Anti-kickback Pawls and Spreader

The blade guard, anti-kickback pawls and workpiece spreader are designed to reduce or eliminate the risk of injury from blade contact, workpiece kickback and wrong way feed.

The Blade Guard:

- serves as a partial barrier to help keep hands from contacting the blade at the infeed end of the saw blade.
- helps keep the workpiece from lifting or fluttering during ripping.
- helps catch or deflect workpiece chips or pieces of the blade.

The Anti-Kickback Pawls :

- help reduce kickback by grabbing into and holding the workpiece.
- act as a barrier to provide some protection from blade contact.

The Spreader:

- helps keep the kerf of the workpiece open, which helps prevent the blade from being pinched and causing workpiece kickback.
- when correctly set, helps reduce or eliminate the chance of wrong way feed because it blocks the workpiece from contacting the saw blade.

⚠ WARNING: The anti-kickback pawls and spreader adjustments must be made each time a different thickness workpiece is cut to reduce or eliminate kickback.

Rip Cutting Checklist

Use the following rip cutting checklist at the beginning of each new cutting period to reduce the risk of an accident.

Rip Cutting Checklist

Yellow key removed from switch.

Saw unplugged and switch off.

No play in the carriage, yoke or column.

Arm slopes to the rear and table level side to side.

Arbor nut snug.

Blade sharp.

Fence secure, solid (knot free), no kerfs.

Fence in correct rip position.

Saw blade desired distance from the fence for cut.

Swivel, bevel, rip, miter and table locks locked.

Blade guard, anti-kickback pawls and spreader adjusted.

Use push stick if cutting between 2 and 6 inches off workpiece.

Use push block if cutting between 1/2 and 2 inches off workpiece.

Use featherboard if making a non-through cut and when needed on through cuts.

Read and follow instructions for the type of rip cut you want to make.

Making a Rip Cut Table Kerf

You will need to make a table kerf before a rip cut can be made. Every time you move the blade a new distance from the fence, you will need to make a new kerf.

1. Put saw in desired rip position and lock the saw arm in the 0° position.
2. Lock rip, swivel, miter, bevel and table locks.
3. Adjust saw arm with handwheel until the saw blade almost touches the table top.
4. Plug the saw into a grounded outlet.
5. Put on safety goggles.
6. Insert the yellow key in the red switch.
7. Turn saw on.
8. Lower saw blade until blade touches the table.
9. Turn the handwheel about 1 full turn more. This will make a 1/16 to 1/8 inch kerf in the table.

⚠ WARNING: For workpieces 1/4 inch thick or less, make the rip kerf at least 1/8 inch deep to keep the saw blade from rising up on top of workpieces and violently throwing them.

10. Turn saw off and remove yellow key.
11. Unplug saw at the end of cutting session.

Adjustments for Ripping

⚠ DANGER: You will need to make blade guard, anti-kickback pawls and spreader adjustments before making a rip cut.

Blade Guard Adjustments

1. Unplug saw and remove yellow key.
2. Put saw in In-Rip position and lock the saw arm in the 0° position.

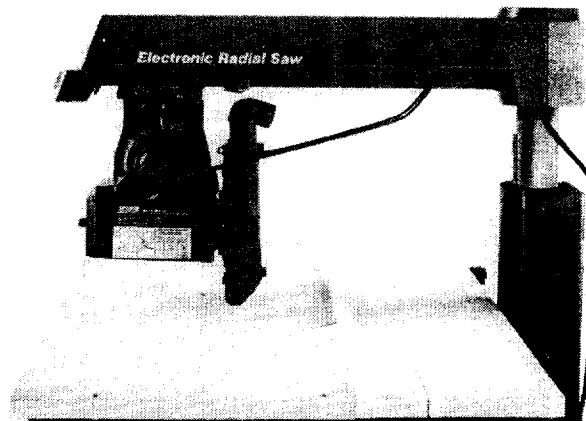

Fig. 129 - In-Rip Saw Position

3. Lock rip, miter, bevel, swivel and table locks.
4. Go to the in-feed end of the saw blade. Fig. 120.
5. Put the workpiece on the table, in line with blade and under the nose of blade guard, so it touches the blade.
6. Loosen the guard clamp screw and rotate the guard until the guard nose just clears the workpiece. Fig. 122.
7. Tighten the guard clamp screw.

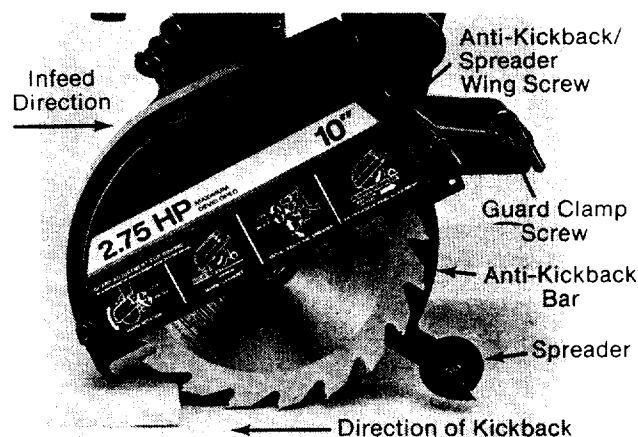

Fig. 130 - Blade Guard Position for Ripping

Anti-kickback Pawls and Spreader Adjustments

1. Go to the outfeed end of the saw blade.
2. Put edge of workpiece beside the blade and under the pawls.
3. Loosen wing screw and lower the anti-kickback pawls and spreader until the spreader hangs next to the edge of the workpiece and the pawls, on one side of the spreader, rest on the workpiece.

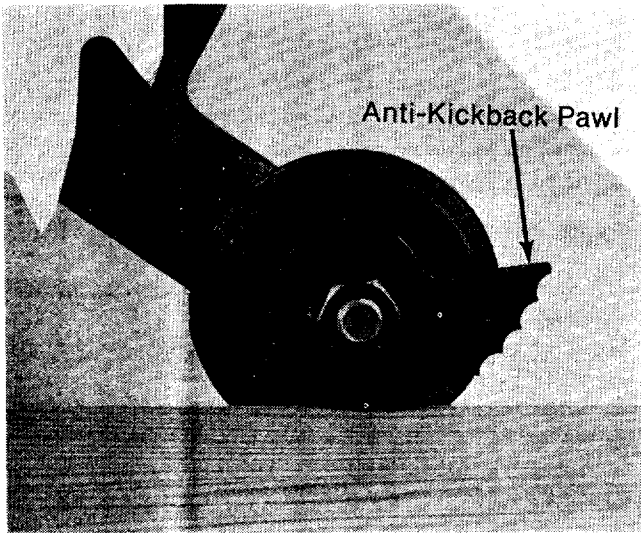

Fig. 131 - Anti-kickback Pawl Position

4. Tighten wing screw.
5. Go to the infeed end of the saw blade.
6. Push the workpiece a few inches in the direction of the cut and then pull the workpiece back toward you. The pawls should have grabbed the wood and stopped the kickback motion by grabbing into the workpiece. If they did not, repeat adjustments until the pawls grab the workpiece. If the pawls fail to grab the workpiece, sharpen or replace them. If that fails to work, use a featherboard. Repeat steps for making anti-kickback pawls and spreader adjustments above.

Making Rip Cuts

When to Use In-Rip or Out-Rip

The in-rip saw position provides better visibility of both the workpiece and your hands than does the out-rip saw position. The only time you should use the out-rip saw position is when the workpiece is 14 inches or wider. Use the in-rip position for all workpieces less than 14 inches wide.

Workpiece Positioning for Ripping

Always set up the saw blade so the widest part of the workpiece is between the blade and the fence. For example, if you want to take 1 inch off an 11 inch wide workpiece, set the saw blade 10 inches from the fence. Do not rip 1 inch off an 11 inch workpiece by setting the saw blade 1 inch from the fence.

⚠ WARNING: If the blade is set between 2 inches and 6 inches from the fence, hands will be brought too close to the blade. Fingers and hand can be cut off. Use a push stick.

For example, if the workpiece is 7 inches wide and you want to cut 1 inch off the workpiece, place the saw blade 6 inches from the fence and use a push stick. Use a push stick when the distance between the saw blade and fence is between 2 inches and 6 inches. See Cutting Accessories section on how to make and use a push stick.

⚠ WARNING: If the blade is set between 1/2 inch and 2 inches from the fence, hands will be brought too close to the blade. Fingers/hand can be cut off. Use an auxiliary fence/push block.

For example, if the workpiece is 3 inches wide and you want to cut 1 inch off the workpiece, place the saw blade 2 inches from the fence and use a push block and auxiliary fence. See Cutting Accessories section.

⚠ WARNING: When making through rip cuts do not set the blade closer than 1/2 inch from the fence or auxiliary fence, your hands will be brought too close to the blade. Your fingers and hand can be cut off. Do not use a radial arm saw to rip cut less than 1/2 inch wide workpieces.

1. Set the blade to desired distance from the fence and lock the saw arm in the 0° position.
2. Lock rip, swivel, miter, bevel and table locks.
3. Make blade guard, anti-kickback pawls and spreader adjustments.
4. Remove workpiece from table.
5. Turn saw on.
6. Place workpiece under the guard nose, keeping workpiece edge against the fence.
7. Place one hand flat on the workpiece and next to fence.
8. Place the other hand behind the first so that your fingers are:
 - on the back edge of workpiece;
 - out of the blade path and,
 - as close to the fence as possible.

⚠ WARNING: Even when all steps to reduce kickback are taken, the workpiece can still kickback. You or others in the area can be hit hard enough to cause broken bones or internal organ injury. Stand out of the line of the saw blade and workpiece.

9. Stand out of the line of the workpiece to be clear of workpiece in case of kickback.



Fig. 132 - Hand and Body Position for Making an In-Rip Cut

10. Position your body at the infeed end of the saw blade. Start and complete the cut from that same side.
11. Push the workpiece, putting pressure on the part of the workpiece between the blade and the fence. If you push the part of the workpiece on the other side of the blade, the blade could be pinched and the workpiece **will** kickback.
12. Keep pushing the section of the workpiece between the blade and the fence until the piece has been pushed completely past the anti-kickback pawls.

⚠ DANGER: The blade guard does **NOT** provide complete protection at out-feed end of the saw blade. The workpiece could kickback as you reach for, touch or pull the workpiece through the blade, pulling your hand into the blade. Fingers, hand, or arm can be cut off. Do not pull, hold-down or touch the workpiece at the outfeed end of the saw.

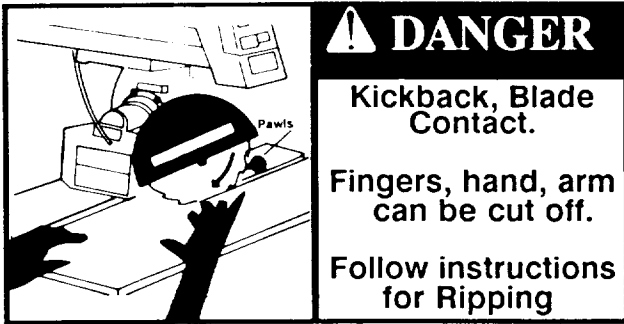

Fig. 133 - Kickback, Blade Contact Safety Sign

13. Turn the saw off

⚠ WARNING: Blade continues to turn for about 12 seconds after power is turned off. Do not reach for cut workpiece until blade stops. Fingers or hand can be cut off by the turning blade. Wait for blade to stop turning.

14. Remove yellow key from red switch.

Bevel Ripping

To make a bevel rip cut:

1. Set the saw in the desired position.
2. Index the arm to 0° and lock in position.
3. Bevel the blade to the desired angle.
4. Follow steps for making a rip cut.

Note: For dadoing, molding and edging, follow instructions for crosscutting.

Dadoing

1. Instructions for using dado blades are provided with the dado blade.
2. The saw arbor is designed for a dado set up to 13/16 inches wide. Use of a wider dado

on the arbor could cause the dado and arbor nut to spin off. Take several passes of the dado if cut required is greater than 13/16 of an inch wide.

3. To avoid excessive load on the motor never cut a 13/16 inch wide dado deeper than 1/8 inch in one pass.

4. When installing the dado on the arbor, always install the inside loose collar first to ensure good arbor nut engagement. Make sure the arbor nut is snug. Install the arbor nut directly against the outside of the dado.

Molding

1. Instructions for using the molding head are provided with the molding head.
2. Use of molding head or drum sander with the saw arbor vertical requires an opening (next to rear face of fence) for saw arbor clearance. See Cutting Accessories section to make a molding fence.

Edging

1. Edging requires the use of a dado or molding head in the horizontal position (parallel to table).
2. Use proper accessory guard when edging. See Recommended Accessories section.

⚠ WARNING: Using the saw without the proper accessory guard for edging is extremely dangerous. Hands, fingers or arm can be cut off. Buy, use and follow instructions for edging guard.

3. Use an auxiliary fence when edging with the radial arm in the 0° miter position. See Cutting Accessories section to make auxiliary fence for edging in the 0° miter position.

⚠ WARNING: If the auxiliary fence is not used when the saw arm is in the 0° crosscut position, the molding head cannot be located behind the fence for safe and proper operation.

4. Edging can also be done in the 30° left miter without the use of an auxiliary fence. Follow the instructions below.

- Miter the arm to the left approximately 30°.
- Swivel the motor until bottom of motor is parallel to and facing the rip fence and operating instructions label is visible.
- Follow all steps outlined on motor label as shown below.

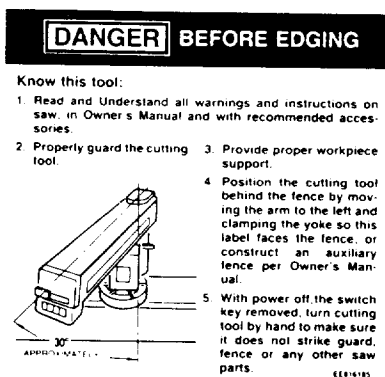

Fig. 134 - Edging Label

Accessory Safety

1. For your safety use only recommended accessories. Use of any other accessories may increase the risk of injury. See Recommended Accessory section of manual.
2. Use of grinding wheels, abrasive or cut off wheels, or wire wheels is dangerous because they can break explosively and throw pieces. You can be blinded or receive a life threatening puncture wound. Do not use grinding wheels, abrasive/cut off wheels or wire wheels.

3. Remove saw blade, dado, or other accessory from the saw arbor shaft before using the accessory shaft. Do not use the saw with accessories installed on both ends of the saw arbor shaft at the same time.

4. Make sure the unused shaft is covered by a guard, the arm, or the screw cap to avoid being pulled into moving parts by hair, threads, clothing.

5. Drill chucks can bend and pieces of the drill bit can break. You can be blinded or injured if hit by thrown pieces. Do not use twist drills longer than 7 inches.

6. Use a spade type drill of 1 inch diameter or smaller. Use for drilling only wood or plastic because the speed is not high enough for other types of materials.

7. Do not use other reduced shank drills.

8. Remove adjusting wrenches. Form habit of checking to see that adjusting wrenches are removed from tool before turning it on.

9. When using the accessory shaft in the vertical position, swivel the motor 90° so that the arbor shaft is under the radial arm as shown.

⚠ WARNING: Clothing, hair, jewelry can be caught and pulled into an exposed arbor shaft. Fingers, hand or arm can be broken or cut off. Place the arbor shaft under the radial arm when using the accessory shaft.

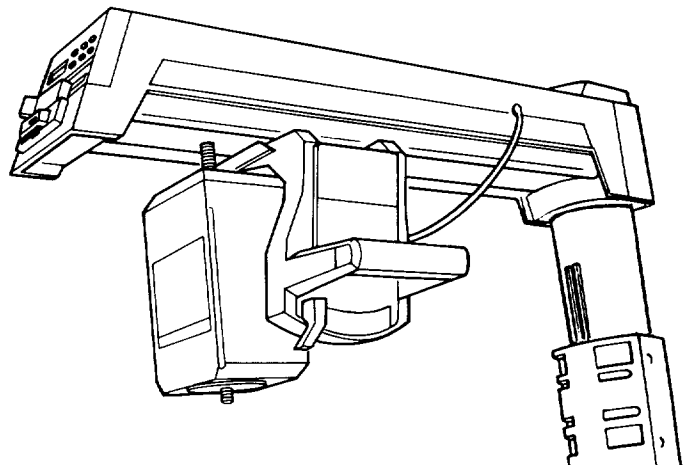

Fig. 135 - Arbor Shaft Position When Using Accessory Shaft

Cutting Accessories

Fences

Fences are required for all saw operations.

Crosscutting requires fences with kerfs (slots) to match the path of the saw, because the saw blade is pulled through the kerf in the fence to cut the workpiece.

Ripping requires a solid fence with no kerfs or slots, because the fence serves as a guide for the workpiece being pushed into the saw blade. If the workpiece is pushed along a fence with kerfs, the workpiece can get caught on a kerf, pinch the blade and cause the workpiece to kickback.

Make a new fence:

- when the fence used for crosscutting has weakened from having too many kerfs cut in it;
- when you want to make a rip cut but the fence on the saw has kerfs;
- when you want to crosscut a workpiece higher than your current fence.

To make a new fence:

1. Use 3/4 inch knot free lumber. Do not use particle board or other composite material because they are not strong enough.
2. Cut lumber to a length equal to the length of the table, and to a width more than half the height of the workpiece being cut, but never less than 3/4 inch.

Push Stick

Push sticks are used during ripping when the blade is placed between 2 and 6 inches from the fence.

Make a push stick when:

- the blade is to be placed 2 to 6 inches from the fence;
- existing push stick has been damaged.

To make a push stick:

1. Use 3/4 inch solid (knot free) piece of lumber.
2. Cut a piece 15 inches long by 1 5/8 inches wide.
3. Cut a 45 degree notch in one end as shown.

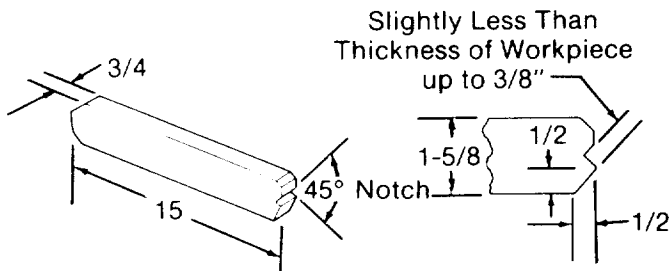

Note: All Dimensions in Inches

Fig. 136 - Push Stick Dimensions

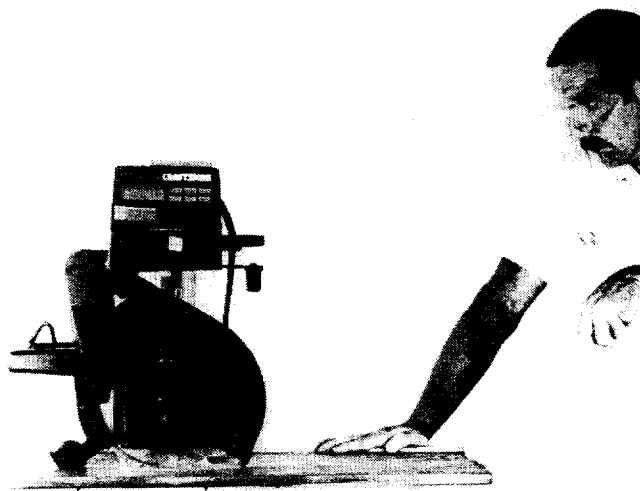

Fig. 137 - Way to Use Push Stick

Auxiliary Fence and Push Block

An auxiliary fence must be used if the blade is positioned between 1/2 inch and 2 inches from the fence during ripping. An auxiliary fence must always be used with a push block. Their purpose is to keep your hands away from the saw blade. They are also needed when you use the molding head.

Make an auxiliary fence when:

- the blade is to be placed 2 inches or less from the fence;
- an existing auxiliary fence is not the same width all along its length;
- the existing auxiliary fence has been damaged by blade contact.

To make auxiliary fence:

1. Use one piece of 3/8 inch plywood and two pieces of 3/4 inch plywood.
2. Cut the 3/8 inch plywood to 40 inches long by 5 1/2 inches wide.
3. Cut one piece of 3/4 inch plywood to 40 inches long by 3 5/8 inches wide.
4. Cut other piece of 3/4 inch plywood to 40 inches long by 2 1/4 inches wide.
5. Glue the two 3/4 inch plywood pieces together so that they line up square (flush) on an edge.
6. Glue the 3/8 inch plywood piece at right angle to and flush against the 2 1/4 inch wide 3/4 inch plywood.
7. Reinforce with nails.

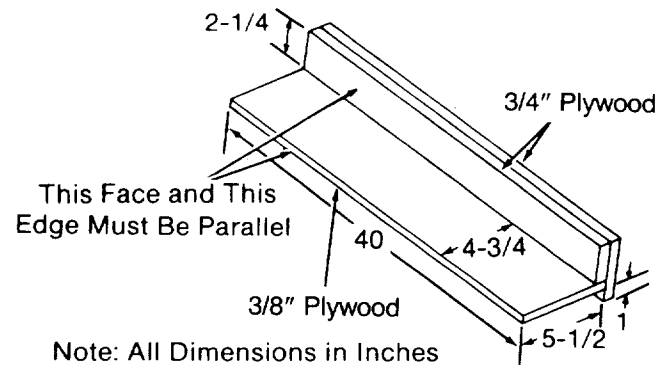

Fig. 138 - Auxiliary Fence Dimensions

Push Block

Push blocks are always used with an auxiliary fence.

Make a push block when:

- the blade is to be placed 1/2 inch to 2 inches from the fence;
- you make the first auxiliary fence;
- existing push block has been damaged.

To make a push block:

1. Use one piece of 3/4 inch plywood and one piece of 3/8 inch plywood.
2. Cut the 3/4 inch plywood to 12 inches long by 5 inches wide.
3. Cut a triangular piece off each of two corners of the 12 inch side by marking with a pencil in and down from the corners 1 1/4 inches and cutting along the diagonal formed by the points.
4. Cut the 3/8 inch plywood to 12 inches long by 5 1/8 inches wide.

5. Cut out a notch from the 12 inch side of the 3/8 plywood that is 9 1/2 inches long by 3/8 inch wide. The dimensions of the remaining 3/8 plywood are shown in Fig. 139.

6. Glue the 3/4 inch plywood on top of the 3/8 inch plywood so that their 12 inch sides are square, as shown;

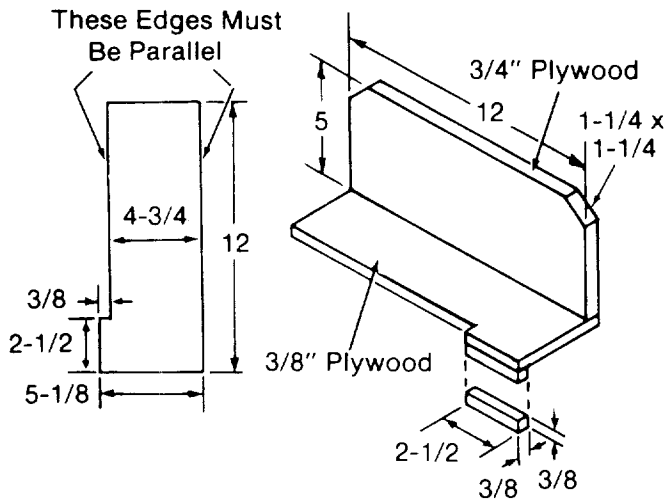

Note: All Dimensions in Inches

Fig. 139 - Push Block Dimensions

7. Cut a piece of plywood 3/8 inch wide by 2 1/2 inches long and glue it to the underside of the 3/8 inch plywood in line with the edge that sticks out. Do not use nails because if you accidentally cut into the push block with the saw blade, the nails will dull the blade.

8. Lay the push block on top of the auxiliary fence to make sure that their widths match exactly, and are each 4 3/4 inches.

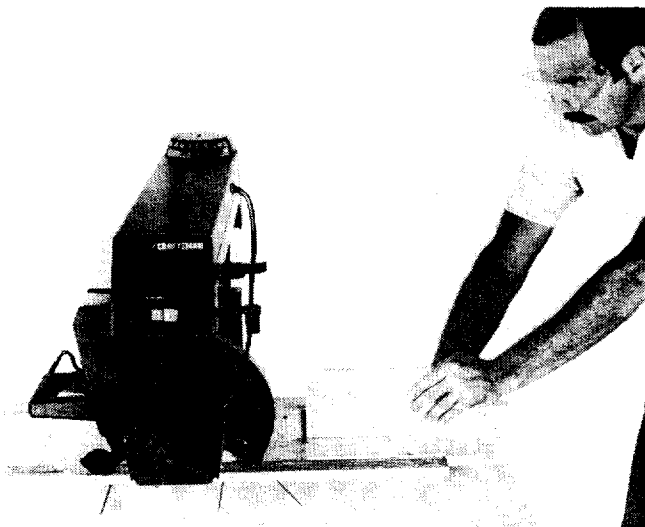

Fig. 140 - Way to Use Auxiliary Fence/Push Block

Auxiliary Fence for Edging

Make an auxiliary fence for edging:

- before doing edging with the arm at 0° miter position.
- when existing ones have been damaged.

To make a fence for edging:

1. Use 3/4 inch solid (knot-free) lumber.
2. Cut to the dimensions shown.

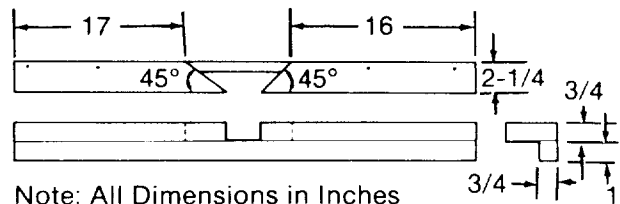
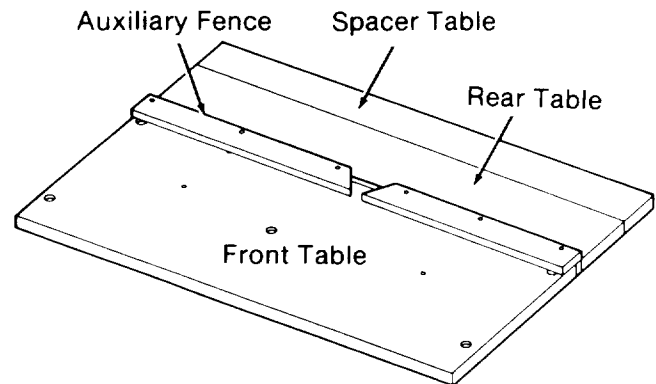

Note: All Dimensions in Inches

Fig. 141 - Auxiliary Fence for Edging

For use of the molding head or drum sander with saw arbor vertical, the rear table requires an opening (next to rear face of fence) for arbor clearance. Cut opening directly below arbor in vertical position. Opening dimensions are shown below.

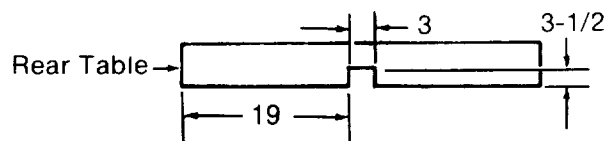

Note: All Dimensions in Inches

Fig. 142 - Rear Table Opening Dimensions

When operating the drum sander the motor **must** be blown or vacuumed frequently to prevent sawdust buildup which will interfere with normal motor ventilation.

Featherboard

Featherboards are used during rip cutting to help keep the workpiece against the fence. The featherboard is clamped to the front table, so that the angled edge of the featherboard is against the workpiece on the infeed end of the blade. The other edge of the workpiece is against the fence.

Make new featherboards when existing ones have been damaged.

1. Use solid (knot free) lumber 24 inches by 5 1/2 inches by 3/4 inch.
2. On the 24 inch sides mark a point 5 1/2 inches down on the left and 9 1/2 inches down on the right from the edge of the board. Draw a line between the points.
3. Crosscut workpiece at a 30° angle then rip to make the kerfs.
4. Do not clamp the featherboard against the cut off part of the workpiece.

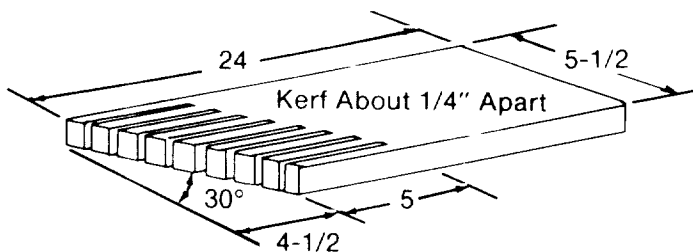

Note: All Dimensions in Inches

Fig. 143 - Featherboard Dimensions

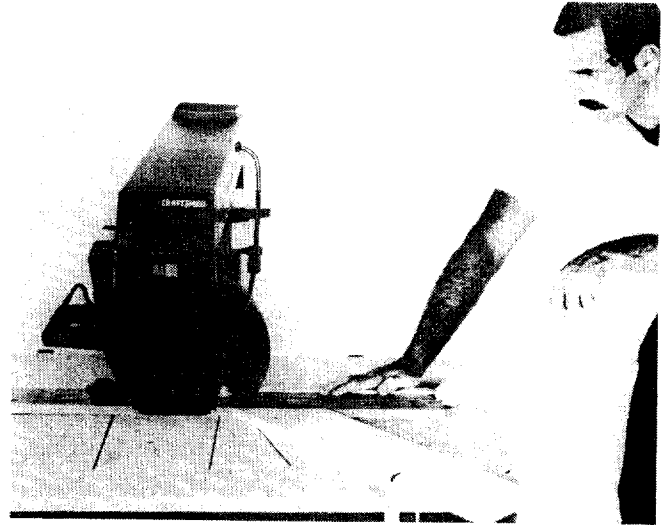

Fig. 144 - Way to Use a Featherboard

Attaching Auxiliary Board to Crooked Workpiece

If the workpiece you want to rip cut does not have a straight edge, attach an auxiliary board to the workpiece.

1. Place irregular side of workpiece against fence.
2. Place straight edged auxiliary board on top of workpiece and against fence.
3. Tack the auxiliary board to the workpiece. The auxiliary board must not extend beyond the leading end of the workpiece and should cover the workpiece width only enough to pass between the blade and fence.
3. Use a fence that is equal to or higher than the combined height of the workpiece and auxiliary board.

Sears Recommends The Following Accessories

Item	Cat. No.
Saw blades (10" diameter with 5/8" hole)	See Catalog
Leg Set Caster	9-22221 or 9-22222
Sanding Drum	9-25246
Drill Chuck and Key	See Catalog
Dust Collector	See Catalog
Molding Head Guard 8"	See Catalog
Taper Jig	See Catalog
Auxiliary Table Cover	See Catalog
Miter Square	See Catalog
Extension Table	See Catalog
Satin Cut Dado	
7"	See Catalog
8"	See Catalog
8" Carbide	See Catalog
Standard Cut Dado	
8"	See Catalog
Adjustable Dado	
7"-24 Tooth Carbide	See Catalog
7"-32 Tooth Carbide	See Catalog
7"-16 Tooth Carbide	See Catalog
8"-48 Tooth Carbide	See Catalog
Molding Heads	
7"-Bits Not Included	See Catalog
7"-27 Piece Set	See Catalog
7"-15 Piece Set	See Catalog
Sanding Wheel-10"	See Catalog
Cabinet Accessories	
Shelf	9-22251
Door	9-22252
3 Drawer Set	9-22253
Books	
Power Tool Know How Handbook	9-29117
Guards	
Lower Retractable Guard (For 90° Crosscut Only)	9-29009

Sears may recommend other accessories not listed in the manual. See your nearest Sears store or Catalog department for other accessories.

Do not use any accessory unless you have received and read complete instructions for its use.

Lower Blade Guard Safety Information

IMPORTANT

The following safety information and instructions apply to all blades and accessories.

The lower blade guard is required by the Occupational Safety and Health Administration (OSHA) if the radial saw is used commercially. The lower blade guard is intended for use only in repetitive 90° crosscutting.

Repetitive 90° Crosscutting is the repeated and continuous cutting of many pieces of lumber to the same length with the saw placed in the 90° crosscut position.

In repetitive 90° crosscutting, the guard may reduce the chance of accidentally touching the blade from the side. This protection is possible **ONLY** when:

- the blade is in its rearmost position and
- the guard is resting on the table so the leading and trailing teeth of the blade are not exposed from the sides.

The lower blade guard **ONLY** provides protection against minor cuts and bruises that occur from contact with the flat sides of the spinning blade.

⚠ WARNING: The lower blade guard will not provide any protection if the blade is pulled over your hand, or your hand enters the blade path from the front or rear of the blade. Fingers or hand can be cut or cut off.

⚠ WARNING

Remove the lower blade guard for ALL other types of cuts except repetitive 90° crosscutting. Using the lower guard other than for repetitive 90° crosscutting will increase the risk of certain hazards:

- During rip and bevel cuts the workpiece or narrow cut-off pieces can be pinched between the guard and the blade. Workpiece or cut-off pieces can kickback.
- In the bevel position the blade teeth are fully exposed. Fingers or hand can be cut off.
- Cut off pieces can jam between the guard and blade. Turn saw off and wait for blade to stop before freeing a jammed guard or blade.
- Workpiece or cut-off pieces can be violently thrown by the blade. Wear safety goggles.

⚠ CAUTION

The lower blade guard can get caught or jam in fence or table kerfs.

Read and follow the warning on the lower outer guard:

**WARNING:
TO AVOID INJURY
SHUT OFF POWER
BEFORE CLEARING A
JAMMED LOWER GUARD**

Read saw manual for additional saw use and safety information.

Glossary

Anti-kickback Pawls: Pivoted objects with teeth which help prevent workpiece kickback.

Arbor: The bar or shaft that holds the saw blade.

Bevel: The slanting of the motor and blade to an angle between 0° and 90°.

Crosscut: Cutting a workpiece to length.

Dado: Non-through cut which produces a square sided notch or trough in the workpiece.

Featherboard: Device used to keep workpiece in contact with the fence during ripping.

Freehand: Performing a cut without the use of fence, guide or hold-down designed to prevent the workpiece from moving during the cutting operation.

Heel: Misalignment of the blade relative to blade travel path.

Infeed: The end of the saw blade where the workpiece is fed during ripping; identified by the absence of pawls.

In-Rip: Positioning the the motor toward the front of the table, the blade toward the fence.

Kerf: Slot caused by removal of material by the blade in a through cut, or a shallow slot produced by the blade in a non-through cut.

Kickback: Uncontrolled throwing of the workpiece during ripping.

Miter: Positioning the saw arm to the right or left of 0°.

Molding Cut: Non-through cut which produces a contoured surface on the workpiece.

Outfeed: The end of the saw blade where the rip cut workpiece leaves the saw blade; identified by presence of pawls.

Out-rip: Positioning the motor toward the fence, the blade toward the front of the table during ripping.

Parallel: When two surfaces are the same distance apart at all points.

Perpendicular: When two surfaces are 90° (square) to each other.

Push Block/Auxiliary Fence: Two accessories used together for ripping a workpiece between 1/2 inch and 2 inches wide.

Push Stick: Cutting accessory used during ripping a workpiece between 2 inches and 6 inches wide.

Revolutions Per Minute (RPM): Number of turns completed by an object in one minute.

Ripping: Used to change the width of a workpiece by cutting along its length.

Spreader: Used during ripping to keep the kerf from closing and pinching the blade. It helps prevent kickback.

Workpiece: Object being cut by the saw.

Helpful Hints

In order to get accurate cutting results from your radial arm saw, do the following:

1. Follow all steps in the Alignment of the Blade section.
2. Place the long edge of your framing square against the edge of the workpiece that will be held against the fence during cutting. Make sure that this edge of the workpiece is straight.
3. Make sure that your workpiece lays flat on the front table of your saw.
4. Clean all sawdust and woodchips from the table.
5. Hold the workpiece firmly against the fence and table during all cuts. You should use extra force during miter and bevel cuts since the workpiece tends to move when these cuts are made.
6. Use the right sawblade for each job, and make sure that all blades and cutting tools are sharp.

3. Place the same edge of the workpiece against the fence for all cuts. Make the first cut at one end of the workpiece, then flip the workpiece over and make the second cut from the other end. Continue this way until all four cuts are made. (Figure 145)

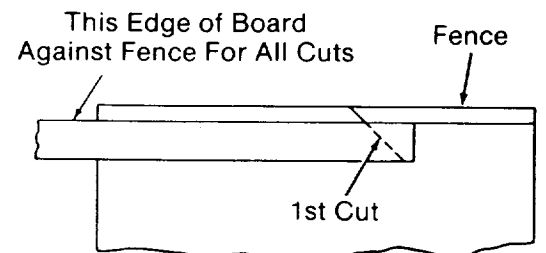

Turn workpiece over end for end . . . keep same edge against fence when making successive cuts.

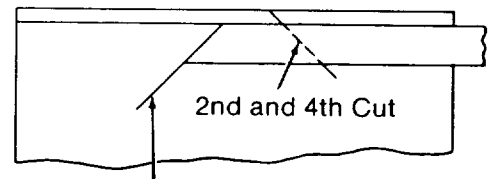

Pencil Line for Gauging Required Length

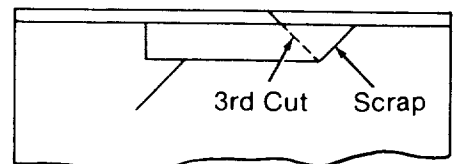

Fig. 145 - Making a 4-Sided Frame

When making a four-sided frame:

1. Make sure that the top and bottom pieces are exactly the same length.
2. Make sure that both side pieces are exactly the same length.

4. Make a pencil line on the table for gauging the length of each cut.

To extend the life of the front table of your saw, tack a piece of 1/4 inch plywood over it. Make sure that the tacks are not in the path of the saw blade.

Use of a front table cover does the following:

- Allows all cuts to be made in the cover rather than the front table.
- Slows the dulling of the blade.

There are three pre-set miter angles at 45°, 0°, and -45°, five pre-set bevel angles at -90°, -45°, 0°, 45°, and 90°, and three pre-set swivel angles at the crosscut, in-rip and out-rip positions. When you are moving the arm, blade, or motor into one of these positions, do the following:

1. Move the arm, blade, or motor past the position you want, and then gradually bring it back.

2. Once the arm, blade, or motor snaps into the desired position, push it to the right as far as possible within this position. Movement of the arm, blade, or motor will be slight.

3. Lock the miter, bevel, or swivel lock.

These steps will reduce stress on saw parts, and improve the accuracy of your cuts.

The following table is provided to convert the decimal numbers on the digital display to fractions. All decimals are rounded to the nearest .01 inch. (Figure 146)

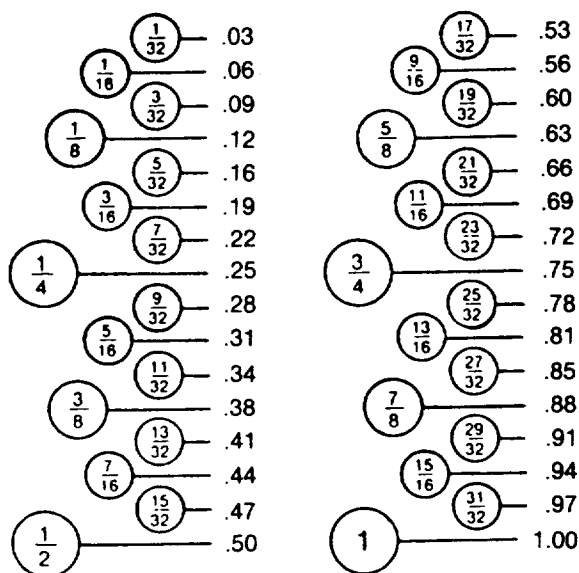

Decimal Equivalent

Fig. 146

Motor

To avoid motor damage this motor should be blown out or vacuumed frequently to prevent sawdust buildup which will interfere with normal motor ventilation.

If the motor fails to start, turn the power switch to the "OFF" position immediately. Remove the yellow key. UNPLUG THE TOOL. Check the saw blade to insure that it turns freely and that its teeth are not wedged into the table top. After the blade has been freed, try to start the motor again. If, at this point, the motor still fails to start, refer to the "Motor Trouble-Shooting Chart."

If the motor should suddenly stall while cutting wood, the power switch should be turned off, remove the yellow key and unplug the power cord. Free the blade from the wood. The motor may now be restarted and the cut finished.

Frequently blowing of fuses or tripping of circuit breakers may result if:

- Motor is overloaded: Overloading can occur if you feed too rapidly or if saw is misaligned so that the blade heels.
- Motor circuit is fused differently from recommendations: Always follow instructions for the proper fuse/breaker. Do not use a fuse/breaker of greater capacity without consulting a qualified electrician.
- Low voltage: Although the motor is designed for operation on the voltage and frequency specified on the nameplate, normal loads will be handled safely on voltages not more than 10% above or below the nameplate voltage. Heavy loads, however, require that voltage at motor terminals equal the voltage specified on nameplate.
- Improper extension cord size.

Maintaining Your Saw

General

⚠ WARNING: For your own safety, turn power switch off and remove plug from power source outlet before maintaining or lubricating your saw.

When you receive your new Craftsman radial saw, it requires no lubrication. The radial saw has been partially aligned and all bearings are lubricated and sealed for life. In time, however, in order to keep your saw in perfect working order and accurate, it will be necessary to lubricate and realign. In fact your radial saw needs more of a cleaning than a lubrication.

Replacing Antikickback Pawls

Make sure the teeth of the *antikickback pawls* are always sharp. If they become dull they must be replaced. With a 1/2 inch wrench or socket remove the 5/16 hex nut and old *pawls*. Reassemble new *antikickback pawls* and *spreader* to the bar. Check *spreader* for proper alignment and correct if necessary. (See Alignment of the Blade, Installing Guard / Setting Spreader section.)

Cleaning

Periodically remove any heavy build-up of sawdust that may accumulate on the saw. The absorbing tendency of sawdust will draw lubricants away from the areas where they are needed. Clean the *carriage bearings* and *track* surfaces. If packed sawdust and grease accumulate repeatedly on carriage bearings and track inspect the *wipers* for wear and replace if necessary. (See Adjustments to Compensate for Wear, Swivel Lock, later in this section.)

To avoid motor damage the *motor* should be blown out or vacuumed frequently to prevent sawdust build-up which will interfere with normal motor ventilation.

Lubrication

Your saw is precision built and should be kept properly lubricated. Before describing the various points which may periodically require lubrication, it is more important to first mention the points which should **not** be lubricated.

Do not lubricate the following:

- carriage ball bearings
- motor bearings
- area between the miter locking rings and the column tube

The *carriage ball bearings* and *motor bearings* are sealed ball bearings which require no added lubrication.

Do lubricate the following, periodically, using SAE No 10W-30 automotive engine oil:

- Apply a few drops of oil along the *swivel index pin* and the *bevel index pin* only if the pins have a tendency to stick. Swivel to in-rip or out-rip for each access to the *swivel index pin*. Bevel to 45° and *bevel index pin* can be easily accessed behind the *yoke* as illustrated. (Figure 147)

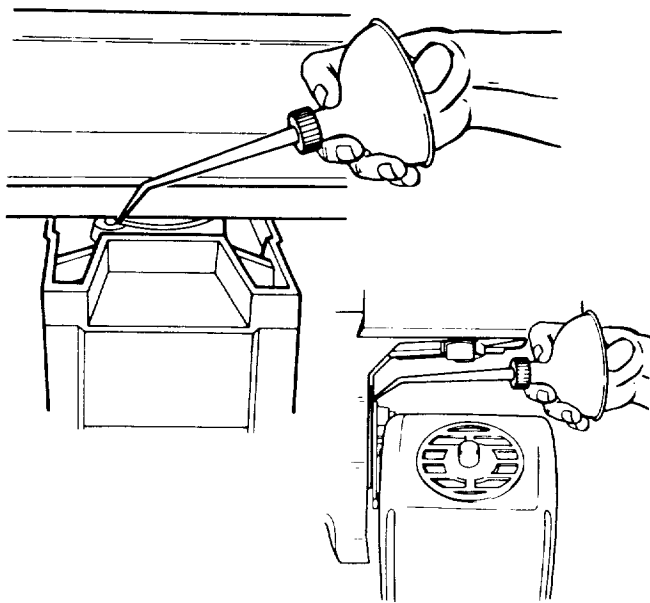

Fig. 147 - Swivel and Bevel Index Pins

- Lubricate the bearing points where the *arm* attaches to the *column tube*. With a #2 Phillips screwdriver remove two screws and the rear arm cover for access to these points. Be careful not to get lubricant on the *locking rings* as this will adversely affect the miter locking function. (Figure 148)

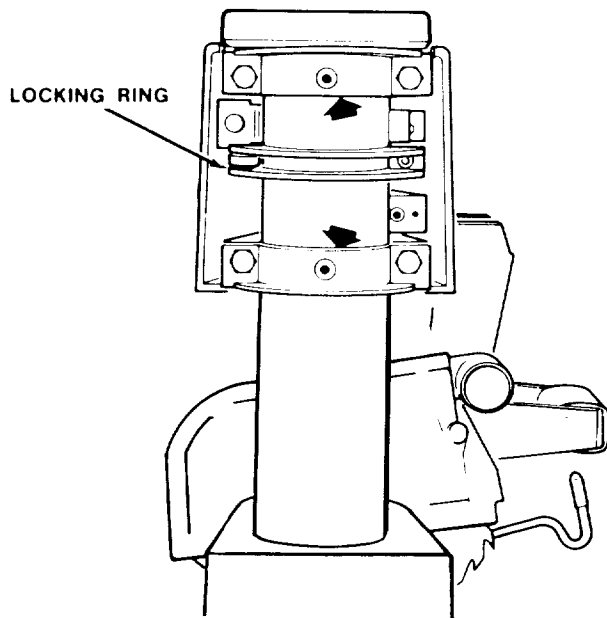

Fig. 148 - Bearing Points Where Arm Attaches to Column Tube

- Lubricate the cam surfaces of the *rip lock* assembly.
- A light film of oil should be wiped on the face of the *column tube* to lubricate the fit between the *column tube* and column support. *Turn the elevation handwheel* to raise the *arm* to upper limit. Wipe a light film of oil on the face of the *column tube*.

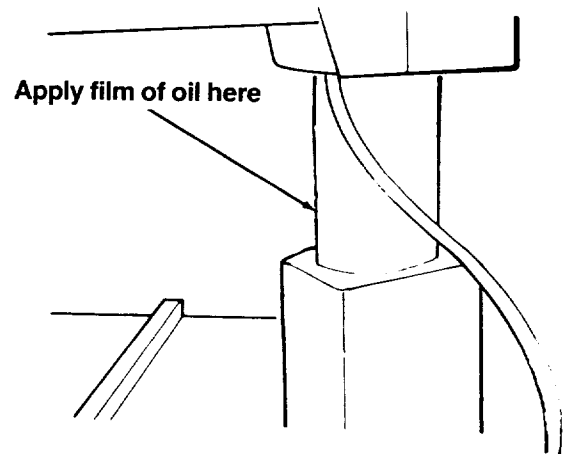

Fig. 149 - Oiling column tube.

- The thread on the *elevation shaft* assembly can be lubricated through the oil hole in the center of the *radial arm cap*. Lubricate ramp on the *swivel index spring*.
- Apply a few drops of oil to the *foot assemblies*, where the *levers* are inserted through the *rods*.

Do not use too much oil. Excessive oil at any location will attract airborne dust particles and sawdust.

Refer to parts lists for locations of parts as needed.

Adjustments for Wear

Bevel Lock

The purpose of the *bevel lock* is to lock the *motor* at any bevel angle. An adjustment is required if the *motor* can be easily moved by hand when the *bevel lock* is locked or if *bevel lock* offers minimal resistance when moving it to the locked position. To make this adjustment:

1. Remove *motor support cover*.
2. Position the motor at approximately 30° bevel angle and lock *bevel lock*. (Figure 150)

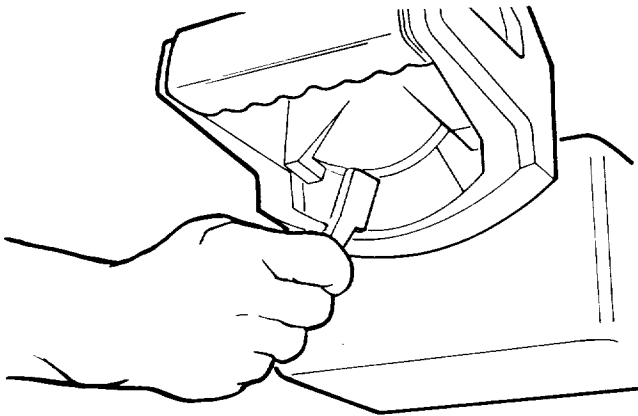

Fig. 150 - Bevel Lock - Locked

3. With a 3/4 socket tighten the 1/2-13 hex nut located at the back of the *motor support casting* until the *motor* can no longer be easily moved by hand. Do not overtighten.
4. Unlock *bevel lock* and move *motor* to any of the five index positions. If the *motor* does not index securely the adjustment is too tight. Loosen 1/2-13 hex nut until *bevel index pin* seats properly.
5. Adjustment is complete when both locking and indexing functions are working properly. Replace *motor support cover*.

Swivel Lock

This *handle* provides a friction lock between the upper face of the *yoke* and the bottom face of the *carriage*. It should eliminate any play or rotation between these two parts when locked. An adjustment is required if the *yoke* can be easily rotated by hand when *handle* is locked or *yoke lock handle* offers minimal resistance when moving *handle* to the locked position. To make this adjustment:

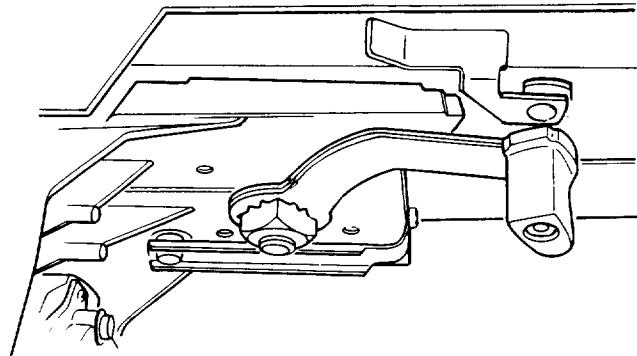

Fig. 151

1. Remove *screw* and *nut* from *knob* on *swivel lock*. Remove *knob* from *swivel lock lever* using a regular screw driver.
2. Separate the *wrench* from the *lever* by rotating the *wrench* a few degrees counterclockwise from the *lever* to disengage *tab*.
3. Using the *wrench* portion, tighten the *square nut* one quarter rotation at a time. This is done by locating the *wrench* across the corners of the *square nut* then moving the *wrench* until it lines up with the *lever* portion.

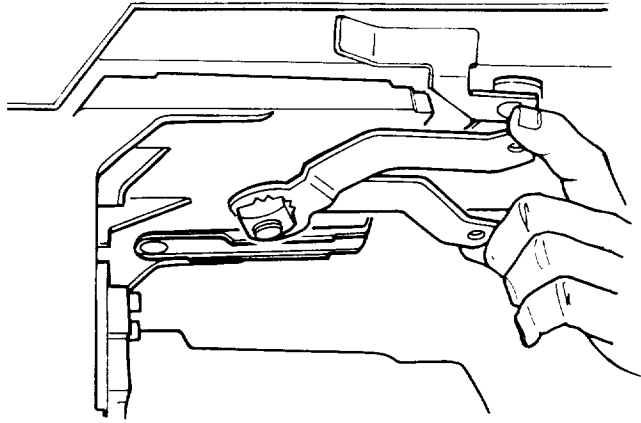

Fig. 152

4. Holding the *wrench* and *lever* in position, rotate *yoke* to a non-preset position and rotate *swivel lock* to the locked position. If the *yoke* can still be moved, the *square nut* has not been tightened enough. Repeat step 3.

5. When the adjustment is such that the *yoke* can no longer be moved when the *swivel lock* is in the locked position, re-insert the *tab* on the wrench into the slot in the *lever*.

6. Unlock *swivel arm* and rotate *yoke* to a non-preset position. Return *yoke* to a rip position. If the *index pin* does not securely seat at the preset position, the adjustment is too tight. Loosen the *square nut* one quarter turn until *swivel index pin* seats securely.

7. Adjustment is complete when both locking and preset position functions are working properly.

8. When the adjustment is such the the *yoke* can no longer be moved when the *swivel lock* is in the locked position, re-insert the *tab* on the wrench into the slot in the *lever*.

9. Re-install *knob* to *swivel handle* and install *screw* and *nut* in *knob*.

Arm and Column

With the *miter lock* unlocked and in the unindexed position the *arm* should fit snugly to the *column tube* and not allow any vertical movement. If you can move the end of the *arm* up and down an adjustment is needed.

1. With a #2 Phillips screwdriver remove two screws and the *rear arm cover*.

2. With a 9/16 inch wrench or socket, tighten evenly the top two 3/8-16 hex head screws. The bottom two screws should also be tightened evenly but not as tight as the top screws. (Figure 153)

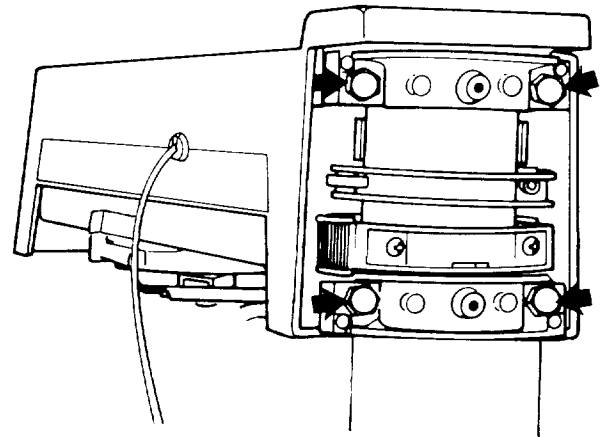

Fig. 153 - Location of Hex Head Screws

3. This adjustment is correct when the *arm* moves firmly without vertical movement.

4. Re-install the *rear arm cover*.

Carriage Bearings

The *carriage* should roll freely but with some resistance for the entire length of travel. To check for bearing looseness, perform the following steps.

1. Place *yoke* in either the in-rip or out-rip position.

2. Push the *carriage* back against the rear stop.

3. Hold the *front carriage bearing* with your fingers as tight as possible and pull *carriage* forward at the same time. If you can prevent the *bearing* from turning an adjustment is required. (Figure 154)

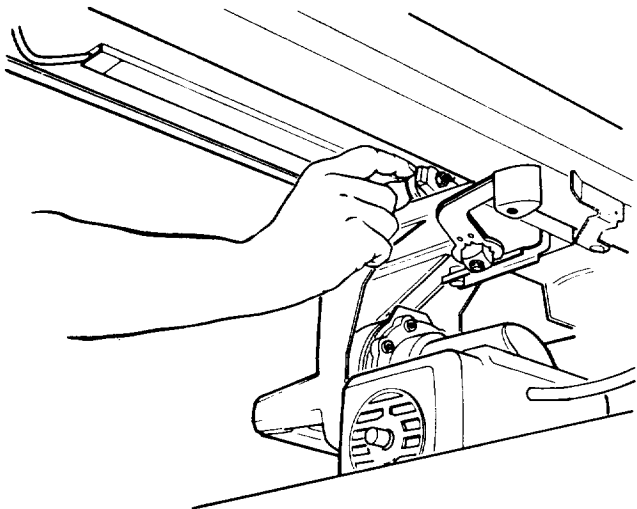

Fig. 154 - Front Carriage Bearings

4. Repeat step 3 with the *rear carriage bearings*.

To adjust the *carriage bearings* perform the following steps:

1. Clean and lubricate the bearing races and the bead on which they ride prior to adjustment.

2. To adjust the bearing, use a 9/16 inch wrench to hold the bolt head while using a 1/2 inch wrench to loosen the hex nut. (Figure 155)

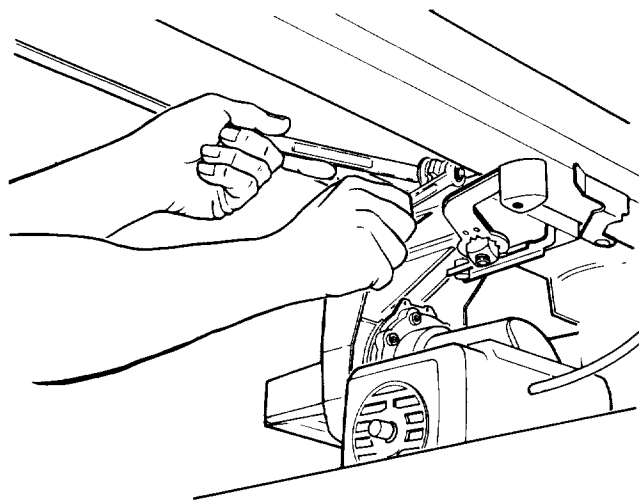

Fig. 155 - Location of Hex Nut

3. Rotate the *eccentric bolts* a partial turn (left or right) as required to take up looseness. Both *bolts* should be adjusted an equal amount to maintain blade squareness to the table in the rip positions.

4. Hold the head of the *eccentric bolts* in their new position and retighten the nuts. Do not overtighten. Overtightening the *bearings* will cause difficult operation and severely reduce the life of the *track* and *bearings*.

5. Repeat the test procedure as described above and readjust if necessary.

Miter Lock

The *miter lock* operates adjustable locking bands which lock the *arm* to the *column tube* in both indexed and unindexed positions. If the *arm* can be easily moved by hand when locked in an unindexed position the following adjustment must be made.

1. Move the *arm* to an unindexed position and leave the *miter lock* in the unlocked position. (Figure 156)

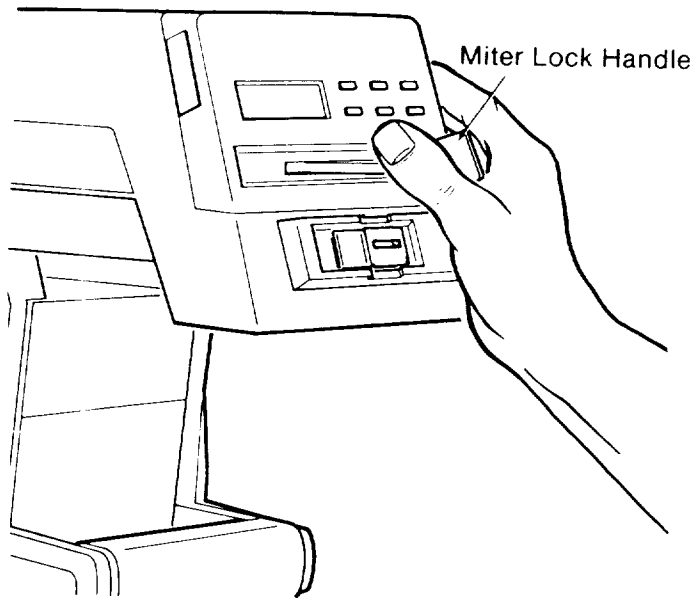

Fig. 156 - Miter Lock - Unlocked

2. With a 3/16 inch hex "L" wrench find the 1/4-20 hex socket cap screw through the hole in the rear of the *arm cover*. To tighten turn the wrench clockwise approximately 1/4 turn. (Figure 157)

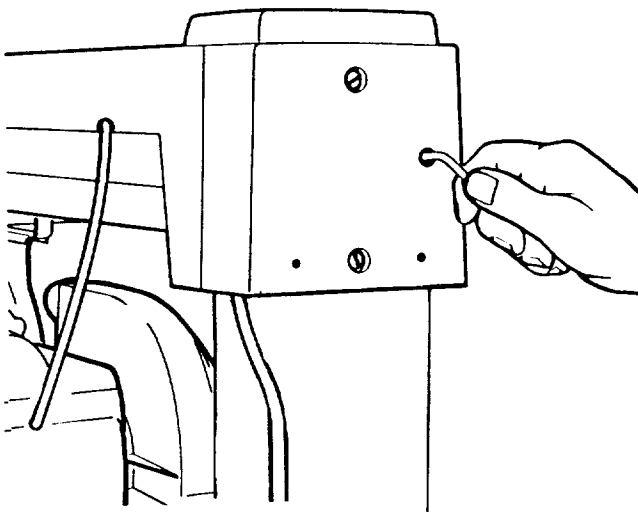

Fig. 157 - Location of Hex Socket Cap Screw

3. Lock the *miter lock* and try again to move the *arm*. Readjust if necessary.

4. If it becomes extremely difficult to push the *miter lock* into the locked position too much adjustment has been made. Turn the wrench counterclockwise one half the amount of the last adjustment and try again to lock the *arm*.

Rip Lock

The *rip lock* locks the *carriage* in any position along the length of the *arm*. If the *carriage* can be easily moved by pushing and pulling on the *yoke handle* when the *rip lock* is in the locked position an adjustment is required.

1. Hold the *rip lock* in the unlocked position and with a 7/16 inch wrench tighten the 1/4-20 hex lock nut 1/4 turn. (Figure 151)

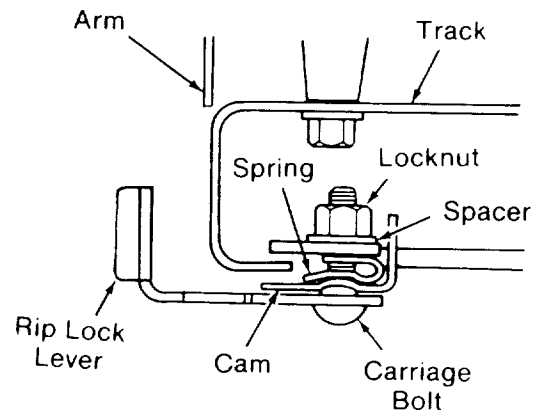

Fig. 158 - Location of Hex Lock Nut

2. Lock the *rip lock* and try again to move the *carriage*. Make additional adjustments if necessary.

3. Place the *rip lock* in the unlocked position and move the *carriage* back and forth from stop to stop. If the *carriage* is difficult to move at any point or you can feel the *rip lock* dragging on the track the adjustment is too tight. Loosen the hex nut one half the amount of the last adjustment and try again.

Troubleshooting

⚠ WARNING: To avoid injury turn power switch off and remove plug from power source outlet before troubleshooting.

Electronics

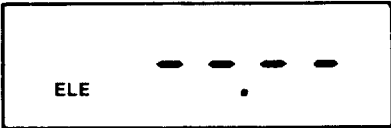
Problem	Probable Cause	What to Do
No display when On/Off button is pressed.	Battery not installed correctly.	Adjust battery position in compartment.
	Battery contacts dirty.	Clean battery contacts.
	Battery dead.	Replace battery with 6V, size J, alkaline battery.
	Indicator display failure.	Contact Sears. Have electronics checked by qualified technician.
Display shows 	Normal display when battery is first installed in unit.	No action required.
	Reference points not set for desired display.	Follow procedure for setting zero reference points in the Setting Electronic Display section.
	Poor battery contact to indicator display leads causing intermittent power to display.	Clean battery contacts. Adjust battery position in compartment.
	Indicator display failure.	Contact Sears. Have electronics checked by qualified technician.
Display dim.	Low battery voltage.	Replace battery with 6V, size J, alkaline battery.
	Saw very cold.	Allow saw to warm to above 32°F.
Display dark.	Saw very warm.	Allow saw to cool to below 120°F.
Display blanks after a few minutes.	Normal.	Press On/Off button. Display should return.
Display blanks when moving carriage, then re-appears when motion stops.	Normal. Sometimes indicator will not display while blade position is changing rapidly.	No action required.

Electronics - 2

Problem	Probable Cause	What to Do
Display shows EEE.E or EE.EE.	Arm or carriage moved too rapidly for indicator to monitor.	Follow procedure for setting zero reference points in the Setting Electronic Display section.
Display will reset to zero but immediately shows EEE.E or EE.EE when arm or carriage is moved.	Encoder or indicator display defective.	Have electronics checked by qualified technician. Repair service available at nearest Sears Store.
Display does not change when arm or carriage is moved.	Wrong indicator function selected.	Select proper function.
	Encoder or indicator display defective.	Have electronics checked by qualified technician. Repair service available at nearest Sears Store.
Display does not read 0°, or 45° at bevel or miter indexes.	Indicator not set to zero reference at index points.	Follow procedure for setting zero reference points in the Setting Electronic Display section.
	Angle encoder not adjusted.	Follow procedure for adjusting encoders in the Setting Electronic Display section.

Motor

Problem	Probable Cause	What to Do
Motor will not run.	Low voltage.	Check power line for proper voltage.
Motor will not run and fuses blow.	Short circuit in line, cord, or plug.	Inspect line, cord, and plug for damaged insulation and shorted wires.
	Short circuit in motor or loose connections.	Inspect all terminals in motor for loose or shorted terminals or worn insulation wires.
	Incorrect fuses in power line.	Install correct fuses.

Motor - 2

Problem	Probable Cause	What to Do
Motor fails to develop full power. (Power output of motor decreases rapidly with decrease in voltage at motor terminals. For example: a reduction of 10% in voltage causes a reduction of 19% in maximum power output of which the motor is capable, while a reduction of 20% in voltage causes a reduction of 36% in maximum power output.)	Power line overloaded with lights, appliances, and other motors.	Reduce the line load.
	Undersize wires or circuit too long.	Increase wire sizes, or reduce length of wiring.
	General overloading of power company's facilities. (In many sections of the country, demand for electrical power exceeds the capacity of existing generating and distribution systems).	Request a voltage check from power company.
Motor overheats.	Excessive feed rate when crosscutting or ripping.	Slow down rate of feed.
	Improper cooling. (Air circulation restricted through motor due to sawdust, etc.)	Clean out sawdust to provide normal air circulation through motor.
	Saw blade has heel.	Refer to Making Blade Parallel to Table section.
Motor starts slowly or fails to come up to full speed.	Starting switch will not trip due to low voltage.	Correct low voltage condition.
Motor stalls resulting in blown fuses or tripped circuit breakers.	Voltage too low to permit motor to reach operating speed.	Correct the low line voltage condition.
	Fuses or circuit breakers do not have sufficient capacity.	Replace fuses or circuit breakers with proper capacity units.
Frequent opening of fuses or circuit breakers.	Motor overloaded.	Reduce motor load.
	Fuses or circuit breakers do not have sufficient capacity.	Replace fuses or circuit breakers.

Saw Operations

Problem	Probable Cause	What to Do
Crosscuts not accurate at 0° and 45° miter.	Looseness between column tube and column support.	Go to Alignment of the Blade, Adjusting Elevation.
	Crosscut travel not square with fence.	Go to Alignment of the Blade, Squaring Crosscut Travel.
	Column is loose in support.	Go to Alignment of the Blade, Adjusting Elevation.
	Arm not indexing properly.	Go to Maintaining Your Saw, Adjustments for Wear, Miter Lock.
	Carriage assembly loose on arm.	Go to Alignment of the Blade, Squaring Blade to Table for Ripping.
	Looseness between yoke and carriage assembly.	Go to Maintaining Your Saw, Adjustments for Wear, Swivel Lock.
	Sawdust between workpiece and fence.	Keep front table clean.
	Fence not straight.	Replace fence.
Saw cuts at slight bevel (not 90° to table).	Work table not properly leveled.	Go to Alignment of the Blade, Leveling Front Table.
	Blade not square to table.	Go to Alignment of the Blade, Squaring Blade to Table for Crosscutting.
	Carriage Bearings Loose	Go to Alignment of the Blade, Squaring Blade to Table for Ripping.
	Bevel lock loose.	Go to Maintaining Your Saw, Adjustments for Wear, Bevel Lock.

Saw Operations - 2

Problem	Probable Cause	What to Do
Workpiece kerf rough with tooth marks from blade (also called heel).	Saw blade not square to fence.	Go to Alignment of the Blade, Squaring Blade to Fence.
	Saw blade not parallel to table.	Go to Alignment of the Blade, Making Blade Parallel to Table.
	Using improper blade for finish cut desired.	Use proper smooth cutting blade.
Wood binds, smokes, and motor slows down or stops when ripping.	Dull blade or warped board.	Sharpen or replace the saw blade. Do not use severely warped material.
	Feed rate too fast.	Slow feed rate.
	Saw blade heels.	Go to Alignment of the Blade, Making Blade Parallel to Table.
	Fence not straight.	Replace fence.
	Carriage assembly loose on arm.	Go to Alignment of the Blade, Squaring Blade to Table for Ripping.
Board pulls away from fence when ripping.	Saw blade has heel.	Go to Alignment of the Blade, Making Blade Parallel to Table.
Workpiece strikes spreader when ripping.	Spreader not in line with blade.	Go to Alignment of the Blade, Installing Guard / Setting Spreader.
Saw does not travel smoothly on arm.	Dirty track.	Clean track and lubricate with light grease.
	Bad bearing.	Replace bearing.
	Worn track.	Replace track.
Clamping force not sufficient at miter angles other than 45°.	Miter lock needs adjustment.	Go to Maintaining Your Saw, Adjustments for Wear, Miter Lock.

Saw Operations - 3

Problem	Probable Cause	What to Do
Clamping force not sufficient at bevel angles other than 45°.	Bevel lock needs adjusting.	Go to Maintaining Your Saw, Adjustments for Wear, Bevel Lock.
Depth of cut varies from one end of the workpiece to the other.	Table top not parallel with arm.	Go to Alignment of the Blade, Leveling Front Table.
Blade tends to advance through lumber too fast.	Dull blade.	Replace or sharpen blade.
	Not advancing saw properly.	Draw saw blade across lumber with a slow and steady pull.
Table cannot be leveled. (Right side is higher than left side with no adjustment left, or vice versa.)	Column support shifted where it mounts to saw base.	Loosen the six bolts that hold the column support to the saw base and shift arm.

**PARTS LIST FOR CRAFTSMAN 10" ELECTRONIC RADIAL SAW
MODEL NOS. 113.197210 and 113.197250**

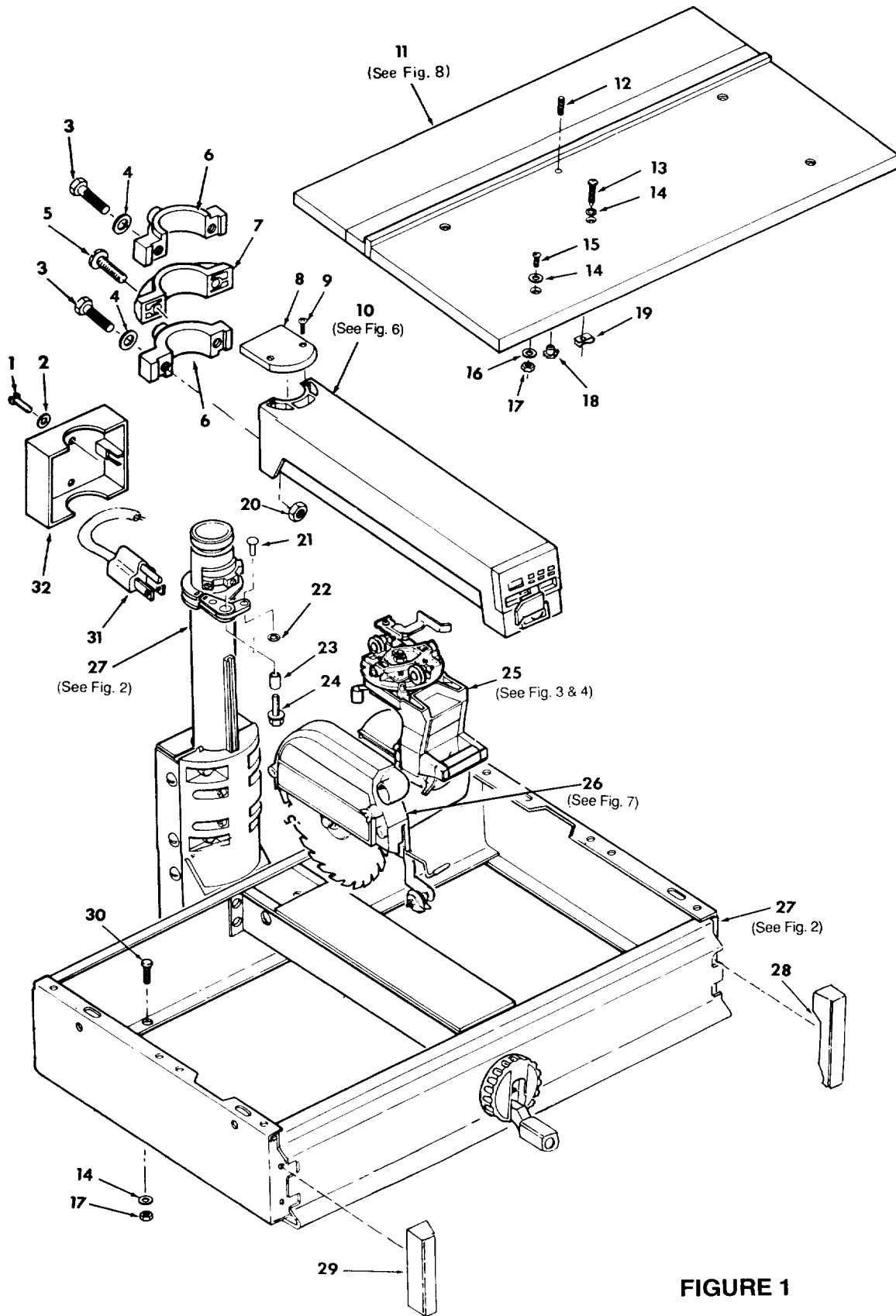

FIGURE 1

**PARTS LIST FOR CRAFTSMAN 10" ELECTRONIC RADIAL SAW
MODEL NOS. 113.197210 and 113.197250**

Always order by Part Number—Not by Key Number

FIGURE 1

Key No.	Part No.	Description
1	816333-1	*Screw, Pan Rec. Type "TT" 10-32 x 1/2
2	STD551010	*Washer, Flat 13/64 x 7/16 x 1/16
3	60339	Bolt Hex Hd. 3/8-16 x 2-1/8
4	60353	Washer, .380 x 47/64 x 1/8
5	808380-6	Screw, Pan Rec. Hd. Plastite No. 8 x 1
6	815649	Bearing, Arm
7	815710	Strap
8	815820	Cap, Arm
9	816333	*Screw, Pan Rec. Hd. Type "TT" 10-32 x 7/8
10	—	Arm Assembly (see Fig. 6)
11	—	Table Board Set (see Fig. 8)
12	60074	Screw, Hex Socket Set 1/4-20 x 7/8
13	806828-3	Screw, Pan Hd. Rec. Type "T" 1/4-20 x 1-3/4
14	STD551012	*Washer, 17/64 x 5/8 x 1/32
15	STD512510	*Screw, Pan Hd. 1/4-20 x 1
16	STD551225	*Lockwasher 1/4

Key No.	Part No.	Description
17	STD541025	*Nut, Hex 1/4-20
18	37384	Nut, Tee
19	815989	Clip, "U" 1/4-20
20	STD541037	*Nut, Hex 3/8-16
21	815774	Rivet, 1/4 x 1/2
22	60208	Nut, Push 1/4
23	815980	Bushing
24	815856-1	Screw, Hex Washer Hd. 5/16-18 x 1-1/4
25	—	Yoke and Motor Assembly (see Fig., 3 & 4)
26	—	Guard Assembly (see Fig. 7)
27	—	Base and Column Assembly (see Fig. 2)
28	818192	Cap, Trim R.H.
29	818193	Cap, Trim L.H.
30	805589-5	Screw, Truss Hd. 1/4-20 x 1/2
31	818172	Cord with Plug
32	815773	Cover, Rear Arm
—	SP5250	Owners Manual (Not Ills.)
—	507967	Bag of Loose Parts (Not Ills.)

*Standard Hardware Item may be Purchased Locally.

**PARTS LIST FOR CRAFTSMAN 10" ELECTRONIC RADIAL SAW
MODEL NOS. 113.197210 and 113.197250**

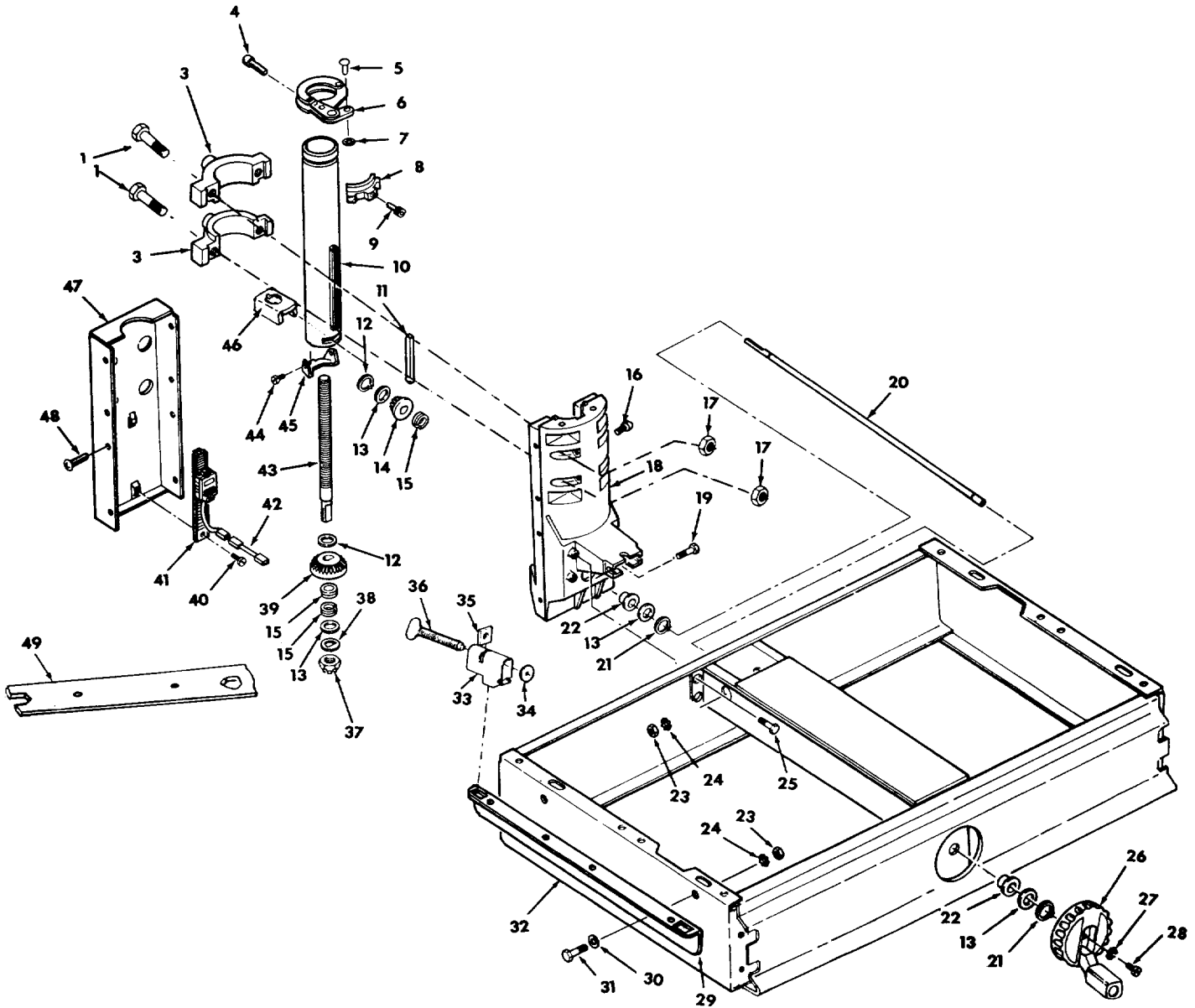

FIGURE 2

**PARTS LIST FOR CRAFTSMAN 10" ELECTRONIC RADIAL SAW
MODEL NOS. 113.197210 and 113.197250**

Always order by Part Number—Not by Key Number

FIGURE 2—BASE AND COLUMN ASSEMBLY

Key No.	Part No.	Description
1	60339	Bolt, Hex Hd. 3/8-16 x 2-1/8
3	815649	Bearing, Arm
4	817398-2	*Screw, Socket Hd. Cap 1/4-20 x 1-1/4
5	815774	Rivet, 1/4 x 1/2
6	818198	Lock Assembly
7	60208	Nut, Push 1/4
8	815763	Latch, Arm
9	816647	Screw, Soc. Hd. Type "T" 1/4-20 x 3/4
10	818226	Tube
11	815770	Gib, Column Tube
12	STD581043	*Ring, Retaining 7/16
13	63500	Washer, Thrust .502 x .927 x .031
14	818165	Gear, Pinion
15	63614	Bearing, Lift Shaft
16	817398-1	Screw, Locking Cap 1/4-20 x 5/8
17	STD541037	*Nut, Hex 3/8-16
18	818212	Support, Column Tube
19	STD523107	*Screw, Hex., Hd. 5/16-18 x 3/4
20	818177	Shaft, Elevating Crank
21	STD582050	*Ring, Retaining 1/2
22	815772	Bushing, Elevation
23	STD541031	*Nut, Hex 5/16-18
24	STD551131	*Lockwasher, External 5/16

Key No.	Part No.	Description
25	9416187	Screw, Hex Hd. Type "T" 5/16-18 x 3/4
26	818237	Handwheel
27	STD551210	*Lockwasher, External #10
28	STD511105	*Screw, Pan Hd. 10-32 x 1/2
29	818199	Channel, Table Mtg.
30	60013	Washer, 11/32 x 7/8 x 1/16
31	STD523107	*Screw, Hex Hd., 5/16-18 x 3/4
32	818215	Base Assembly
33	818166	Bracket, Clamp
34	818161	Shoe, Table Clamp
35	120399	*Nut, Square 5/16-18
36	818162	Screw, Clamp
37	STD541450	*Nut, Lock 1/2-13
38	817106	Washer, Keyed
39	818164	Gear, Bevel
40	STD610803	Screw, Pan Rec. Hd. Type "AB" #8 x 3/8
41	815749-1	Encoder, Elevation
42	817022	Cord, Elevation
43	818167	Shaft, Elevating
44	STD601103	*Screw, Pan Rec. Hd. Type "T" 10-32 x 3/8
45	815826	Actuator, Elevation
46	818224	Nut, Elevation
47	815864	Cover, Column Support
48	815865	Screw, Hex Washer Hd. Type "T" 1/4-20 x 1/2
49	3540	Wrench

*Standard Hardware Item may be Purchased Locally.

**PARTS LIST FOR CRAFTSMAN 10" ELECTRONIC RADIAL SAW
MODEL NOS. 113.197210 and 113.197250**

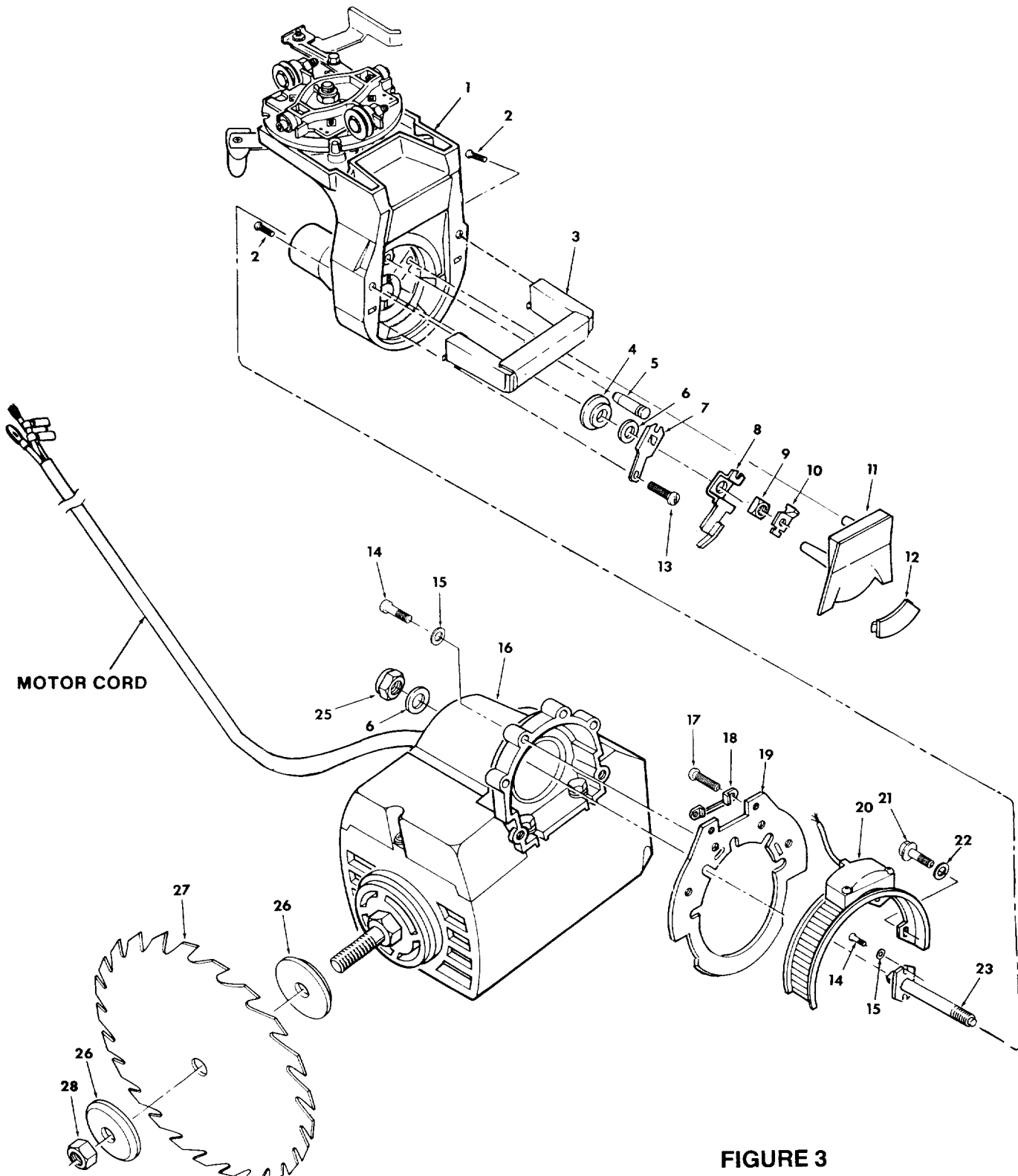

FIGURE 3

**PARTS LIST FOR CRAFTSMAN 10" ELECTRONIC RADIAL SAW
MODEL NOS. 113.197210 and 113.197250**

Always order by Part Number—Not by Key Number

FIGURE 3—YOKE AND MOTOR ASSEMBLY

Key No.	Part No.	Description
1	—	Yoke Assembly (see Figure 4)
2	818922	Screw, Flat Hd., Plastite No. 8 x 1
3	818202	Handle, Yoke
4	815678	Washer, Shaft
5	815679-1	Pin, Index
6	805561-10	Washer, .505 x 7/8 x 1/16
7	815791	Spring, Bevel
8	818154	Lever, Bevel Lock
9	815813	Nut, Square 1/2-13
10	815836	Wedge, Bevel Spring
11	818204	Cover, Yoke
12	815799	Plug, Yoke
13	806828	Screw, Pan Hd. Type "T" 1/4-20 x 1/2
14	815992	Screw, Soc. Hd. Type "TT" 1/4-20 x 5/8

Key No.	Part No.	Description
15	STD551012	*Washer, 17/64 x 9/16 x 1/16
16	818888	•Motor (Complete) (See Fig. 5)
17	STD510802	*Screw, Pan Hd. Type "T" 8-32 x 5/16
18	815802	Guide, Bevel Reader
19	818197	Plate, Index
20	815751	Encoder, Bevel
21	STD601103	*Screw, Hex Washer Hd. Type "T" 10-32 x 1/2
22	STD551010	*Washer, 3/16 x 3/8 x 1/32
23	508153	Shaft Support
25	805839-1	Nut Lock 1/2-13
26	62498	Collar, Blade
27	9-32668	†Blade, Saw
28	30495	Nut, Shaft

*Standard Hardware Item may be Purchased Locally.

†Stock Item may be Secured Through the Hardware Department of Most Sears Retail or Catalog Order Houses.

•Any attempt to repair this motor may result in unit misalignment and create a HAZARD unless repair is done by a qualified service technician. Do not loosen the three screws holding the motor support to the motor. This assembly is factory aligned. Repair service is available at your nearest Sears Store.

**PARTS LIST FOR CRAFTSMAN 10" ELECTRONIC RADIAL SAW
MODEL NOS. 113.197210 and 113.197250**

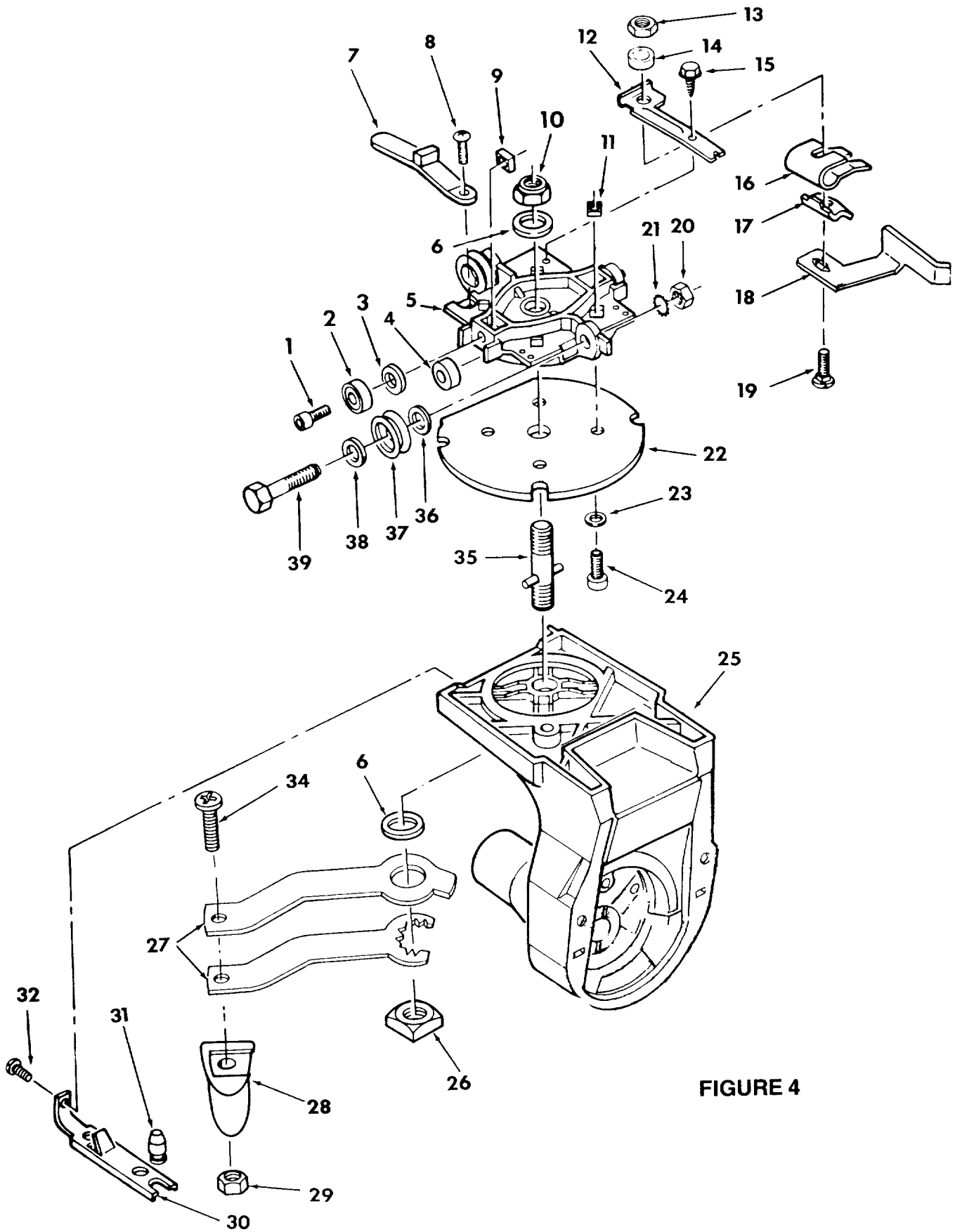

FIGURE 4

**PARTS LIST FOR CRAFTSMAN 10" ELECTRONIC RADIAL SAW
MODEL NOS. 113.197210 and 113.197250**

Always order by Part Number—Not by Key Number

FIGURE 4—YOKE ASSEMBLY

Key No.	Part No.	Description
1	810214-3	Screw, Low Hd. Cap 5/16-18 x 7/8
2	STD315485	*Bearing, Ball .3150 I.D.
3	STD551031	*Washer, 21/64 x 5/8 x 1/32
4	817181	Wiper, Track
5	815689	Carriage
6	STD551062	*Washer, .360 x 1-1/8 x 3/32
7	815827	Actuator, Rip
8	STD600803	*Screw, Pan Rec. Hd. Type "T" 8-32 x 3/8
9	815817	Nut, Square Lock
10	STD541462	*Nut, Lock 5/8-11
11	62636	Nut, Square 1/4-20
12	815693	Bracket, Rip Lock
13	STD541425	*Nut, Lock 1/4-20
14	62520	Spacer
15	273229	Screw, Hex Hd. Type "T" 1/4-20 x 1/2
16	816497	Spring, Rip Lock
17	815671	Cam, Rip Lock
18	818155	Lever, Rip Lock
19	STD532510	*Bolt, Carriage 1/4-20 x 1
20	STD541231	*Nut, Hex Jam 5/16-18

Key No.	Part No.	Description
21	STD551131	*Lockwasher, External 5/16
22	815691	Ring, Yoke Index
23	STD551012	*Washer, 17/64 x 7/16 x 1/32
24	817398-1	Screw, Cap Locking, 1/4-20 x 5/8
25	818207	Yoke
26	109529	Nut, Square 5/8-11
27	508155	Wrench, Adjustment
28	816988	Knob, Swivel
29	STD541025	*Nut, Hex 1/4-20
30	815680	Spring, Swivel
31	815679	Pin Index
32	806828	Screw, Pan Hd. Type "T" 1/4-20 x 1/2
34	STD512515	*Screw, Pan Hd. 1/4-20 x 1-1/2
35	815694	Stud, Yoke Clamp
36	STD551031	*Washer, 21/64 x 3/4 x 1/16
37	63777	Bearing, Carriage
38	60438	Washer, No. 2 Carriage Bearing
39	815807	Screw, Eccentric

*Standard Hardware Item may be Purchased Locally.

**PARTS LIST FOR CRAFTSMAN 10" ELECTRONIC RADIAL SAW
MODEL NOS. 113.197210 and 113.197250**

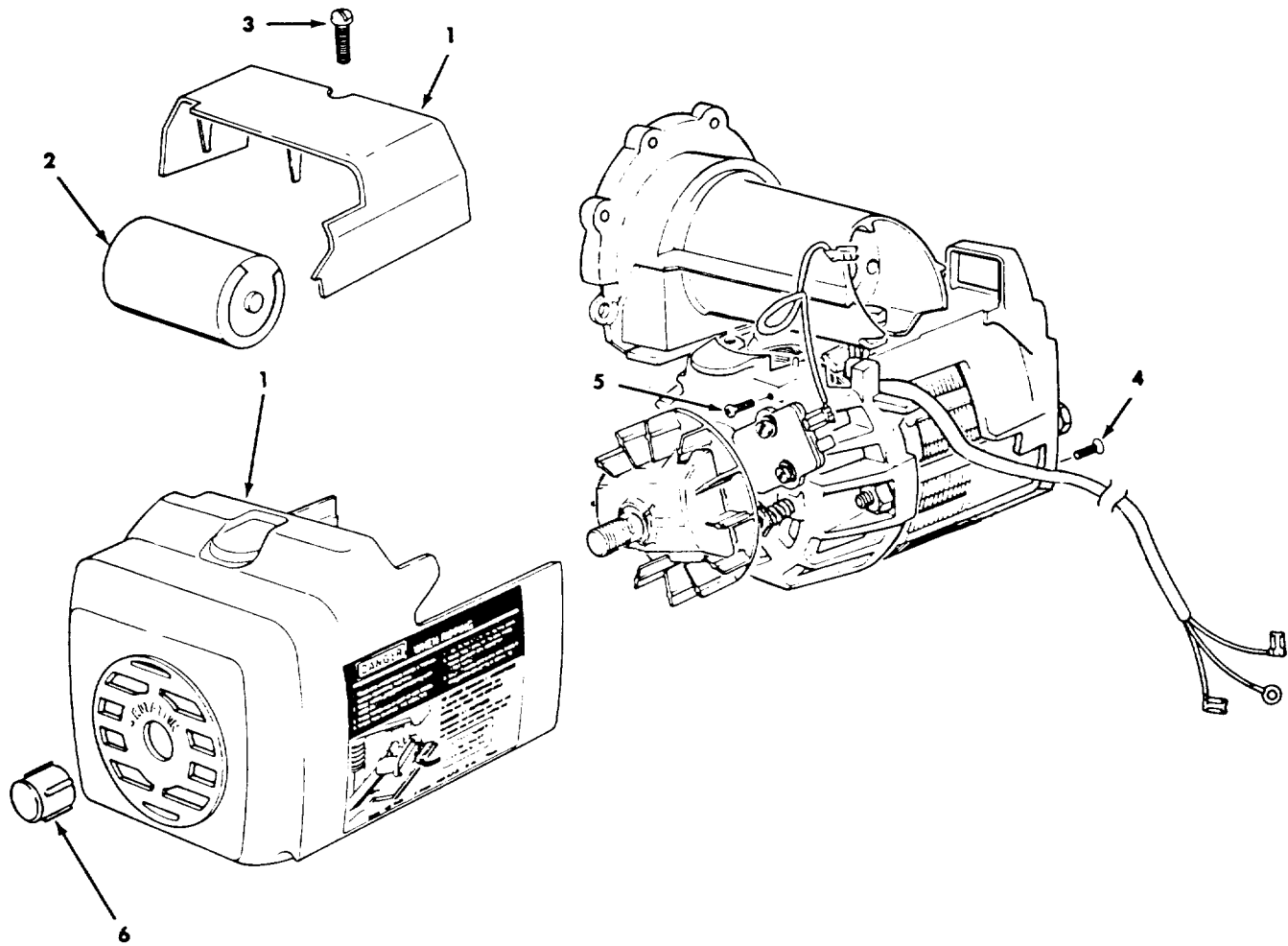

FIGURE 5

**PARTS LIST FOR CRAFTSMAN 10" ELECTRONIC RADIAL SAW
MODEL NOS. 113.197210 and 113.197250**

Always order by Part Number—Not by Key Number

FIGURE 5—MOTOR ASSEMBLY

Key No.	Part No.	Description
1	507744	Housing, Motor
2	STD376116	*Capacitor
3	64950	Screw, Type "T"
4	64951	Screw, Flat Head
5	64948	Screw, Ground
6	30582	Cap, Shaft

*Standard Hardware Item may be Purchased Locally.

**PARTS LIST FOR CRAFTSMAN 10" ELECTRONIC RADIAL SAW
MODEL NOS. 113.197210 and 113.197250**

Always order by Part Number—Not by Key Number

FIGURE 6—ARM ASSEMBLY

Key No.	Part No.	Description
1	818239	Arm, Radial
2	169123-2	Relief, Strain
3	815809	Cable
4	815774	Rivet, 1/4 x 1/2
5	818182	Actuator Assembly
6	60208	Push Nut, 1/4
7	STD601103	*Screw, Pan Rec. Type "T" 10-32 x 3/8
8	815703	Knob, Miter Lock
9	815856	Screw, Hex Washer Hd. 5/16-18 x 3/4
10	815779	Bushing
11	815741	Controls, R.S.
12	STD363539	•Battery
13	815735	Lid, Battery Access
14	815704	Housing, Switch
15	STD551208	*Lockwasher, Internal #8
16	STD600803	*Screw, Pan Rec. Hd. Type "T" #8-32 x 3/8
17	63467	Cap, Flag Terminal
18	816113	Switch, Locking
19	9-22256	†Key, Switch
20	815976	Bezel, Switch
21	STD375006	Connector, Wire

Key No.	Part No.	Description
22	818521	Bumper, Rubber
23	816492	Clip, Wire
24	815789	Relief, Strain
25	STD601103	*Screw, Pan Rec. Hd. Type "T" #10-32 x 3/8
26	816490	Encoder, Rip (Includes Key #23)
27	815784	Label, Trim L.H.
28	816333-3	Screw, Pan Hd. Type "TT" 10-32 x 5/8
29	STD551210	*Lockwasher, Ext. #10
30	816178	Sleeve, Rubber
31	815867	Spring, Compression
32	815708	Spring, Miter Lock
33	STD551010	*Washer, 13/64 x 5/8 x 1/32
34	815752	Encoder, Miter
35	808380-10	Screw, Pan Rec. Hd. Plastite #10-14 x 3/8
36	815868	Relief, Strain
37	818088-1	Track, Arm
38	346030	Screw, Pan Rec. Hd. 8-10 x 1/2
39	818536	Label, Trim R.H.

*Standard Hardware Item may be Purchased Locally.

•Can also use these battery numbers:

Eveready #539

Rayovac #867

Duracel #7K67

†Stock Item may be secured through the Hardware Department of Most Sears Retail or Catalog Order Houses.

**PARTS LIST FOR CRAFTSMAN 10" ELECTRONIC RADIAL SAW
MODEL NOS. 113.197210 and 113.197250**

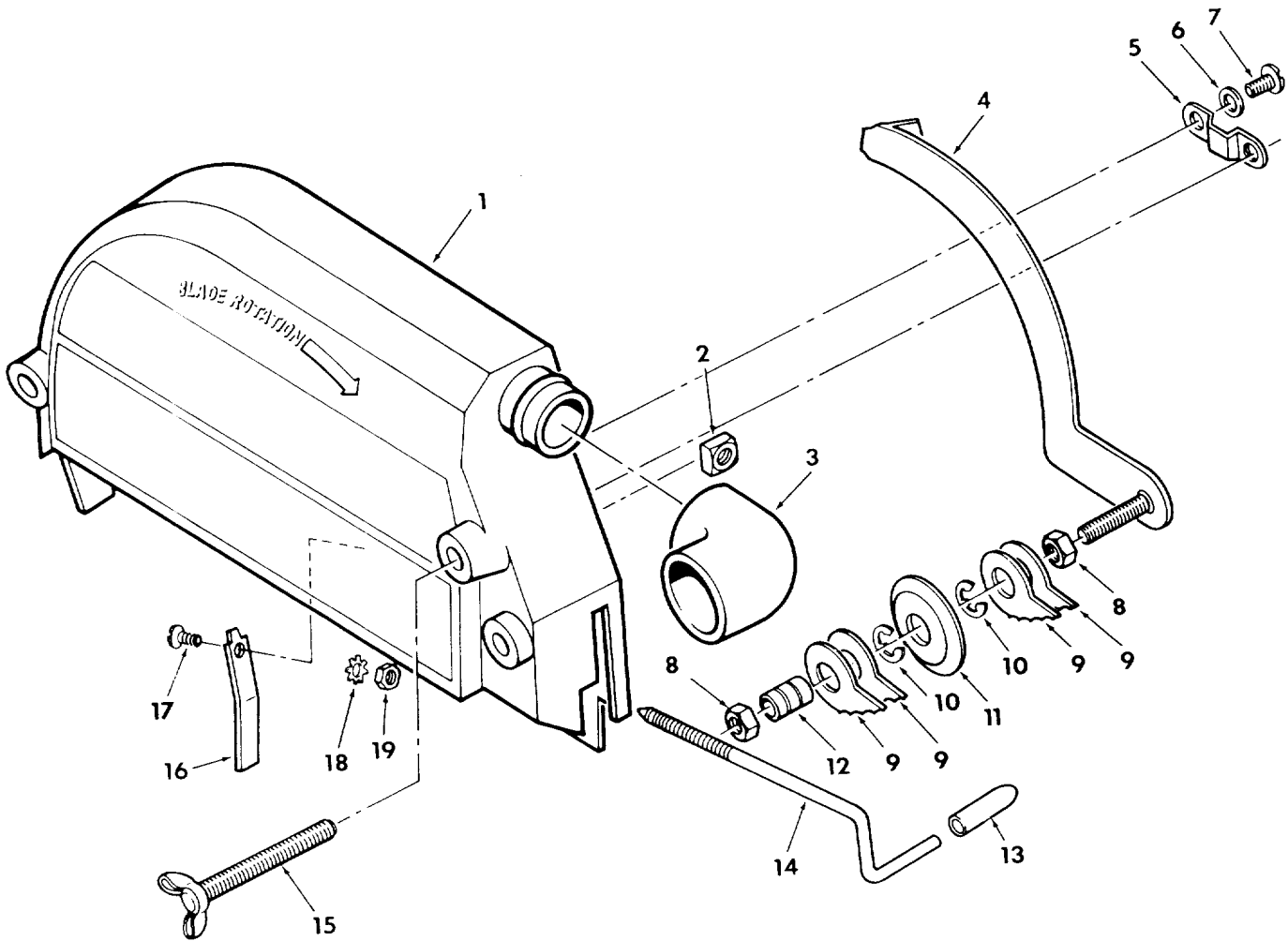

FIGURE 7 - GUARD ASSEMBLY

Always order by Part Number - Not by Key Number

Key No.	Part No.	Description
1	816264-1	Guard
2	120399	*Nut, Square 5/16-18
3	63258	Elbow, Dust
4	63541	Bar, Anti-Kickback
5	815816	Guide, Anti-Kickback
6	STD551010	*Washer, 13/64 x 5/8 x 1/32
7	STD601103	*Screw, Pan Hd. Type "T" 10-32 x 3/8
8	STD541231	*Nut, Hex Jam 5/16-18
9	815815	Pawl

Key No.	Part No.	Description
10	STD581050	*Ring, Retaining
11	63270	Spreader
12	816341	Bearing (Includes Key #10)
13	60435	Grip
14	816070	Screw, Guard Clamp
15	166785-3	Screw, Wing 5/16-18 x 2-3/4
16	63538	Clamp, Guard
17	STD510805	*Screw, Pan Hd. 8-32 x 1/2
18	STD551208	*Lockwasher, External No. 8
19	STD541008	*Nut, Hex 8-32

*Standard Hardware Item may be Purchased Locally.

**PARTS LIST FOR CRAFTSMAN 10" ELECTRONIC RADIAL SAW
MODEL NOS. 113.197210 and 113.197250**

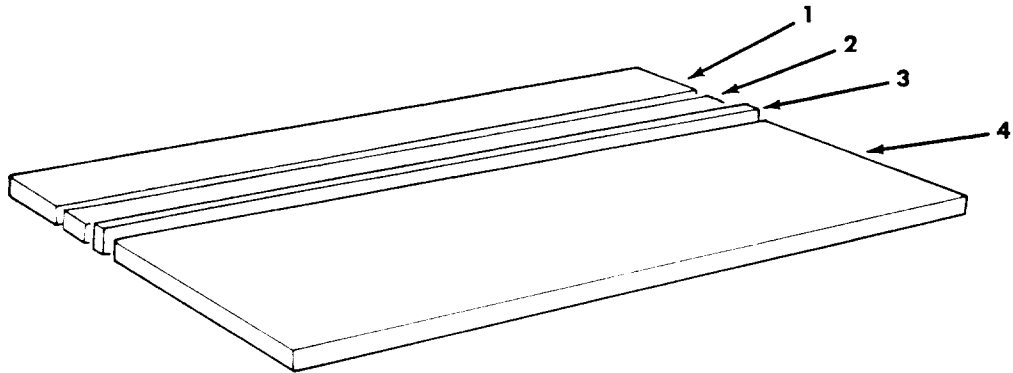

Always order by Part Number - Not by Key Number

FIGURE 8 - TABLE ASSEMBLY

Key No.	Part No.	Description
1	818169	Table, Rear
2	818168	Table Spacer
3	63432	Fence, Rip
4	818191	Table, Front

*Standard Hardware Item may be Purchased Locally.

**PARTS LIST FOR CRAFTSMAN 10" ELECTRONIC RADIAL SAW
MODEL NOS. 113.197210 and 113.197250**

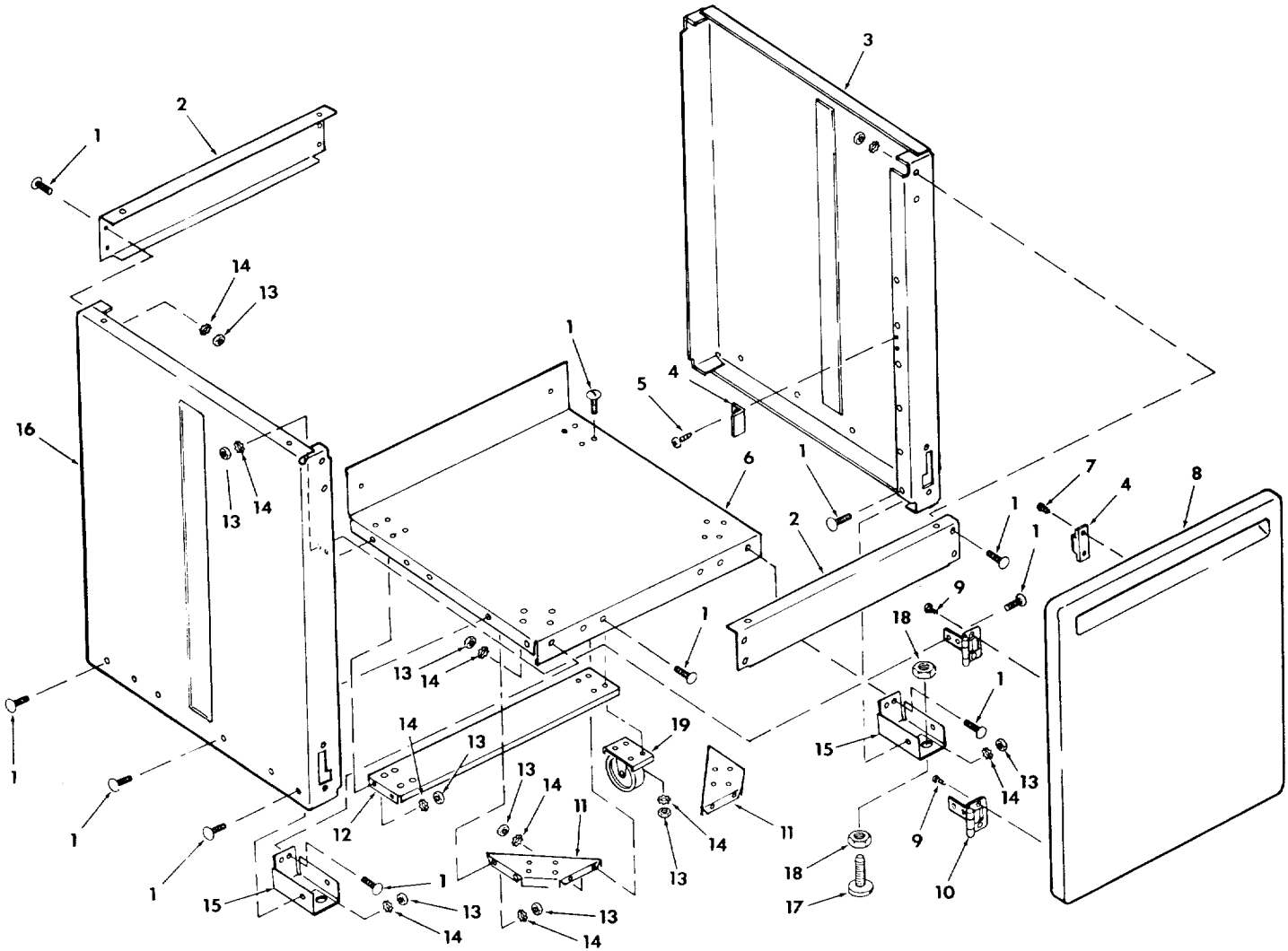

Always order by Part Number—Not by Key Number

FIGURE 9—PARTS LIST 23" CABINET (MODEL 113.197210 ONLY)

Key No.	Part No.	Description
1	805589-5	Screw, Truss Hd 1/4-20 x 1/2
2	815900	Skirt 23"
3	817151	Panel, Side R.H.
4	815933	Catch, Magnetic
5	STD600603	*Screw, Pan Hd. Type "T" 6-32 x 3/8
6	815887	Shelf, Lower 23"
7	816274	Screw, Pan Hd. Plastite 6-10 x 1/2
8	815882	Door, Cabinet
9	816274-1	Screw, Pan Hd. Plastite 10-10 x 1/2

Key No.	Part No.	Description
10	815934	Hinge, Door
11	815993	Bracket, Corner
12	816063	Stiffener, Shelf
13	STD541025	*Nut, Hex 1/4-20
14	STD551225	*Lockwasher, Ext. 1/4
15	817108	Spacer
16	817150	Panel, Side L.H.
17	803835-1	Foot, Leveling
18	STD541237	*Nut, Hex Jam 3/8-16
19	816004	Caster, Stationary
—	507530	Bag of Loose Parts (Not Ills.)
—	508166	Bag of Loose Parts (Not Ills.)

*Standard Hardware Item may be Purchased Locally.

**PARTS LIST FOR CRAFTSMAN 10" ELECTRONIC RADIAL SAW
MODEL NOS. 113.197210 and 113.197250**

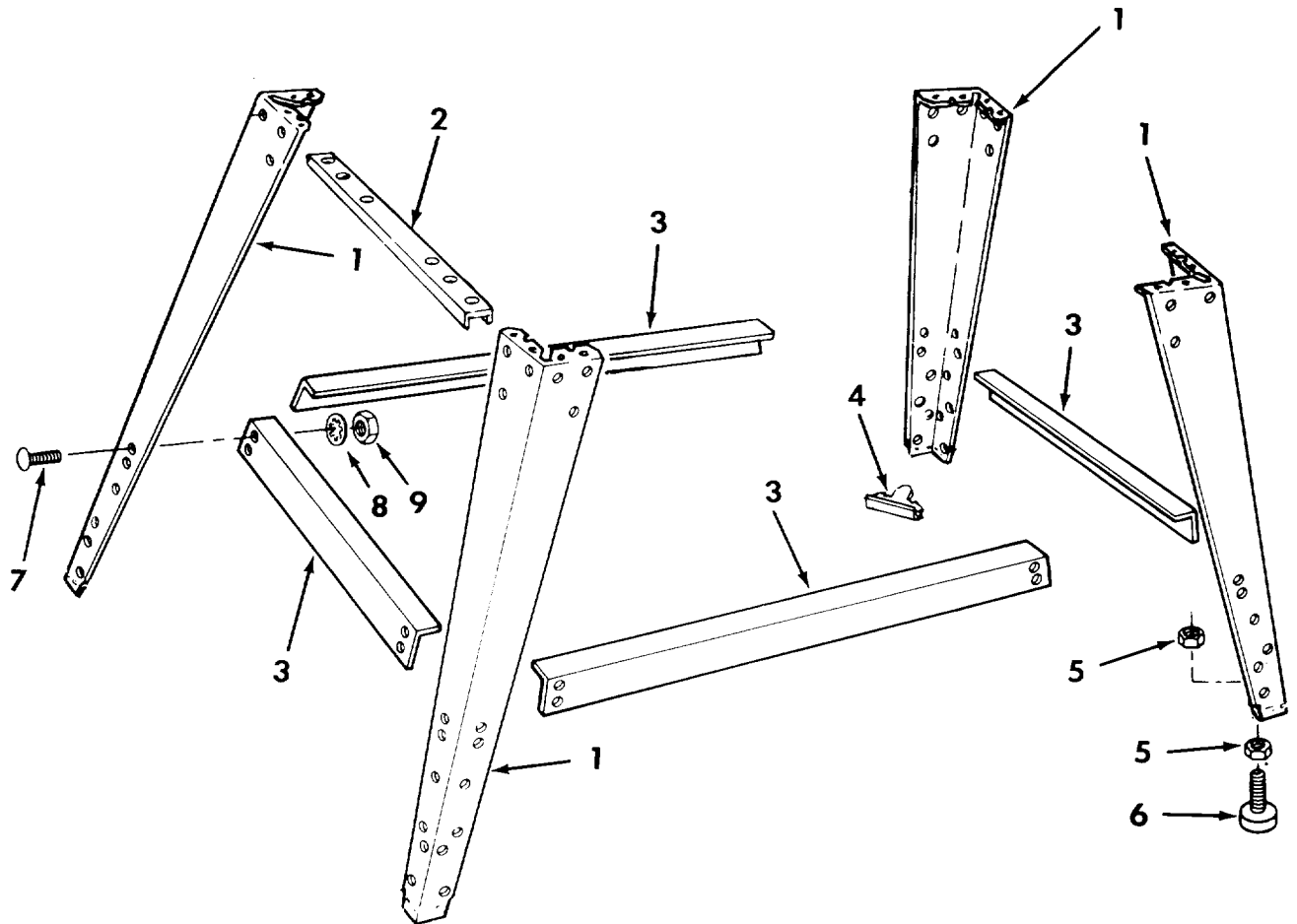

Always order by Part Number—Not by Key Number

FIGURE 10—LEG SET (MODEL 113.197250)

Key No.	Part No.	Description
1	818213	Leg
2	818163	Channel, Leg
3	815909	Stiffener, Lower
4	818170	Bracket, Leg
5	STD541237	*Nut, Hex Jam 3/8-16
6	803835-1	Foot, Leveling
7	805589-5	Screw, Truss Hd. 1/4-20 x 1/2
8	STD551225	*Lockwasher, Int. 1/4
9	STD541025	*Nut, 1/4-20
—	507968	Bag of Loose Parts (Not Ills.)

*Standard Hardware Item may be Purchased Locally.



Operators Manual

SERVICE

MODEL NO. 113.197210

10" ELECTRONIC
RADIAL SAW WITH
23" CABINET AND
1 DOOR

or

113.197250

10" ELECTRONIC
RADIAL SAW WITH
LEG SET

HOW TO ORDER REPAIR PARTS

10-INCH ELECTRONIC RADIAL SAW

Now that you have purchased your 10-inch electronic radial saw, should a need ever exist for repair parts or service, simply contact any Sears Service Center and most Sears, Roebuck and Co. stores. Be sure to provide all pertinent facts when you call or visit.

The model number of your 10-inch electronic radial saw will be found on a plate attached to your saw, at the left-hand side of the base.

WHEN ORDERING REPAIR PARTS, ALWAYS GIVE THE FOLLOWING INFORMATION:

PART NUMBER	PART DESCRIPTION
MODEL NUMBER	NAME OF ITEM
113.197210	ELECTRONIC
113.197250	10-INCH RADIAL SAW

All parts listed may be ordered from any Sears Service Center and most Sears stores. If the parts you need are not stocked locally, your order will be electronically transmitted to a Sears Repair Parts Distribution Center for handling.

Sold by SEARS, ROEBUCK AND CO., Chicago, IL. 60684 U.S.A.