

FILE

# ASSEMBLY, OPERATING INSTRUCTIONS AND PARTS LIST FOR CRAFTSMAN ACCRA-ARM 10 INCH RADIAL SAW

J. M. JENKINS

JUN 29 1967

## MODEL NUMBER 113.29410

The Model Number will be found on a plate attached to your saw, at the left side of the base. Always mention the Model Number in all correspondence regarding the CRAFTSMAN ACCRA-ARM RADIAL SAW or when ordering repair parts.

Carefully read the instructions provided, observe the simple safety precautions and you will have many hours of satisfactory use from your new Craftsman tool.

## HOW TO ORDER REPAIR PARTS

All parts listed herein may be ordered through SEARS, ROEBUCK AND CO. or SIMPSONS-SEARS LIMITED. When ordering parts by mail from the catalog order house which serves the territory in which you live, selling prices will be furnished on request or parts will be shipped at prevailing prices and you will be billed accordingly.

WHEN ORDERING REPAIR PARTS, ALWAYS GIVE THE FOLLOWING INFORMATION AS SHOWN IN THIS LIST:

- |                    |                                |
|--------------------|--------------------------------|
| 1. The PART NUMBER | 3. The MODEL NUMBER 113.29410  |
| 2. The PART NAME   | 4. The NAME of item—RADIAL SAW |

## COAST TO COAST NATION-WIDE SERVICE FROM SEARS FOR YOUR CRAFTSMAN ACCRA-ARM RADIAL SAW



SEARS, ROEBUCK AND CO. and SIMPSONS-SEARS LIMITED in Canada back up your investment with quick, expert mechanical service and genuine CRAFTSMAN replacement parts.

If and when you need repairs or service, call on us to protect your investment in this fine piece of equipment.

**SEARS, ROEBUCK AND CO.-U. S. A.**  
**IN CANADA, SIMPSONS - SEARS LIMITED**



# POWER TOOL SAFETY...AND YOU

**3 MINUTES** of required reading for the home Craftsman... whether this is your first purchase or you're an old hand at power tools.

YOU'VE JUST BOUGHT A QUALITY SEARS TOOL, designed to give you many years of top performance and trouble-free operation. It's also designed with

safety in mind, permitting you to use the tool without concern so long as certain basic rules are observed.

We'd like to call particular attention to some of the more **important rules** to follow for maximum enjoyment of your Sears power tools.

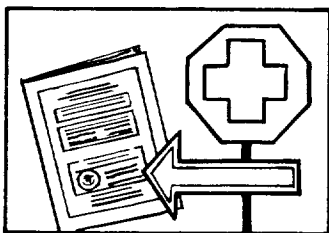

## 1. READ THE INSTRUCTION MANUAL...

completely • accurately. Pay special attention to safety precautions and use of safety features.

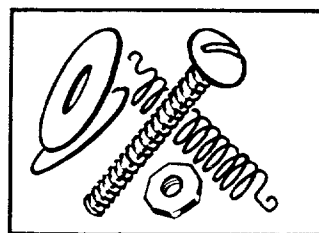

## 2. INSPECT THE POWER TOOL THOROUGHLY

Set up the machine according to instructions. Make certain all parts are included.



## 3. FOLLOW OPERATING INSTRUCTIONS CAREFULLY

They have been developed to insure correct procedure and prevent accidents.



## 4. DRESS PROPERLY FOR THE WORKSHOP

Get rid of loose clothing, roll up sleeves, remove your tie, wear a snug-fitting shop apron.

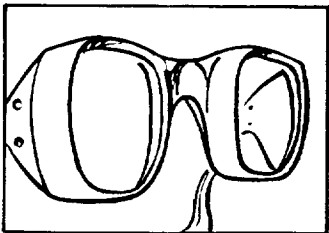

## 5. WEAR SAFETY GLASSES

Safety glasses or eye shields are recommended for all power tool operations.

## 6. USE PROPER ELECTRICAL CONNECTIONS

Make certain proper voltage (110 or 220) is used. USE A GROUND WIRE; AND A SUITABLE PLUG, IF REQUIRED. Check fusing requirements of the tool as outlined in the instruction manual.

Get in the habit of turning off the tool when not in use.

Disconnect input cable from power supply when adjusting tool from one working position to another.

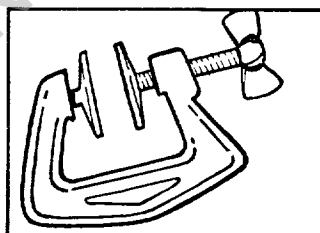

## 7. DOUBLE-CHECK HOLDING FIXTURES

Lock all clamps tightly. Spin parts by hand to check against misalignment or looseness before turning on tool.

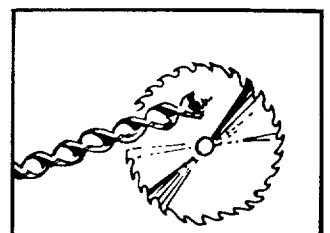

## 8. KEEP CUTTING TOOLS SHARP

Make certain blades, drills, cutters, etc., are in top shape. Dull tools can cause rough cuts, excessive chipping... and accidents.

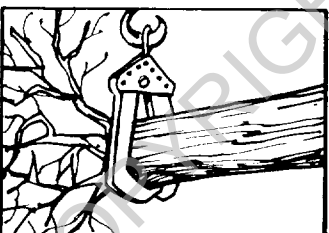

## 9. DON'T EXCEED THE LIMITS OF THE POWER TOOL

Abusing the power tool by doing work beyond its capacity reduces its life and increases the chance of injury to the operator. Watch especially the sizes of the work and feed rate.



## 10. KEEP SPECTATORS AWAY

Curiosity and interest on the part of the family is fine, but avoid inspections when the power tool is running.

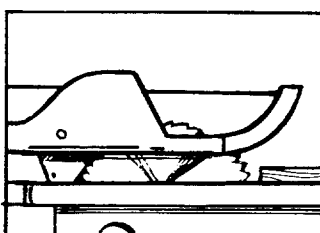

## 11. SAFETY GUARDS

Accessory safety guards are available for most tools. Use of these guards is highly recommended.

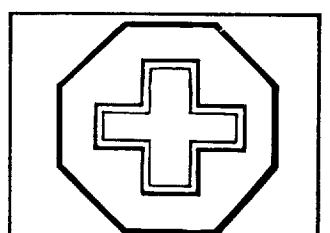

## 12. THINK SAFETY

Carefully plan each operation before turning on tool.

# ASSEMBLING AND ADJUSTING YOUR SAW

## POWER SUPPLY & MOTOR CONNECTIONS

### MOTOR SPECIFICATIONS

The AC motor used in this saw is a capacitor start, non-reversible type, with the following specifications:

Voltage	115/230
Amperes	10/5
Cycles	60
Phase	Single
RPM	3450
Rotation (viewed from saw blade end)	Clockwise

**CAUTION:** This saw is wired for 115 volt operation. Connect to 15 Amp. Branch Circuit and use 15 Amp. Time-Delay Fuse.

### ELECTRICAL CONNECTIONS

**NOTE:** This saw motor is wired at the factory for 115 volt, 60 cycle, AC service as shown in figure 1 and described in paragraph 1, below. Under normal home workshop use with proper voltage to the motor, the saw will operate with adequate efficiency. However, if any of the following conditions exist, it may be necessary to reconnect the saw for 230 volts AC as described in paragraph 2, below.

1. Continuous heavy-duty use.
2. Undersize wiring in circuit from motor to power source, or overloaded circuit.
3. Low voltage from power source to motor (which may be due to overloaded power source).

The power cord must also be changed from the 115-volt type to the 230-volt type, when changing to 230-volt operation.

- 1. Connections For 115-Volts AC.** (See figure 1.) When replacing a motor or connecting the saw to 115-volts for any reason, make sure the wires inside the motor terminal box are connected as follows:
  - a. Connect the WHITE, BLACK and RED leads from the motor terminal box to the WHITE motor cord lead. (The black motor cord lead is already connected to the overload protector.
  - b. Connect the GREEN and BROWN leads to the BLUE lead.
  - c. Twist bare ends of wires together and install a wire nut on each connection.
  - d. Push all leads carefully into motor terminal box and install terminal box cover.
- 2. Connections For 230-Volts AC.** (See figure 2.) When connecting the motor for 230-volt operation, the following connections must be made inside the motor terminal box:
  - a. Connect the WHITE and BLACK leads from motor terminal box to the WHITE motor cord lead. Twist bare ends together and install a wire nut as shown in figure 2.
  - b. Leave the BROWN lead (from overload protector) disconnected and insulate it with tape to prevent short circuiting inside motor terminal box.
  - c. Connect the GREEN, RED and BLUE leads together, twist bare ends and install a wire nut.
  - d. Push all leads carefully into motor terminal box and install terminal box cover.

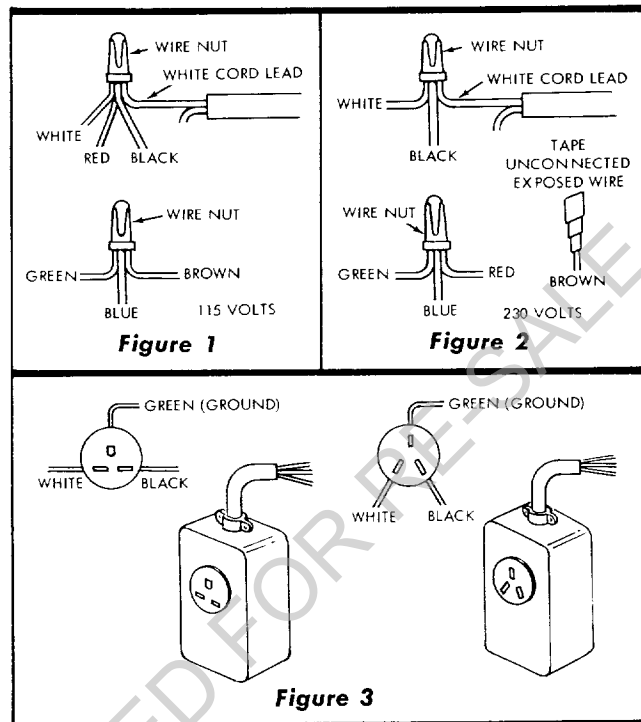

### 3. Modifying the Power Cord. (See figure 3.)

- a. Change the power cord terminal by cutting off the existing molded plug (for 115-volts), and attach a 230-volt plug.
- b. Either a tandem or crow-foot plug and receptacle may be used, as shown in figure 3.

**CAUTION:** Do not connect the standard 115-volt plug to a 230-volt receptacle.

### MOTOR SAFETY PROTECTION

The saw motor is equipped with a manual-reset thermal overload protector, designed to open the power line circuit when the motor temperature exceeds a safe value.

1. If the protector opens the line and stops the saw motor, press the saw switch to the "OFF" position immediately and allow the motor to cool.
2. After cooling to a safe operating temperature, the overload protector can be closed manually by pushing in the red button on the motor capacitor cover. If the red button will not snap into place immediately, the motor is still too hot and must be allowed to cool for a while longer. (An audible click will indicate protector is closed.)
3. As soon as the red button will snap into running position, the saw may be started and operated normally by pressing the saw switch to the "ON" position.
4. Frequent opening of fuses or circuit breakers may result if motor is overloaded, or if the motor circuit is fused with a fuse of greater capacity without consulting the power company.
5. Although the motor is designed for operation on the voltage and frequency specified on motor nameplate, normal loads will be handled safely on voltages not more than 10% above or below the nameplate voltage. Heavy loads, however, require that voltage at motor terminals be not less than the voltage specified on nameplate.
6. Most motor troubles may be traced to loose or incorrect connections, overloading, reduced input voltage (which

results when small size wires are used in the supply circuit) or when the supply circuit is extremely long. Always check connections, load and supply circuit when the motor fails to perform satisfactorily. Check wire sizes and lengths with the table in the next paragraph.

### WIRE SIZES

The following table lists recommended wire sizes for connecting the motor to the power source. These sizes should be maintained for trouble-free operation of the saw.

Length of Conductor	Wire Size Required (American Wire Gauge No.)	
	115 Volt Lines	230 Volt Lines
50 feet or less . . . . .	No. 12	No. 14
100 feet or less . . . . .	No. 10	No. 12
100 feet to 150 feet . .	No. 8	No. 10
150 feet to 200 feet . .	No. 6	No. 8
200 feet to 400 feet . .	No. 4	No. 6

**NOTE:** For circuits of greater length, the wire size must be increased proportionately in order to deliver ample voltage to the saw motor.

### MOUNTING THE SAW ON A WORK BENCH

The saw should be placed on a suitable sturdy work bench and the base positioned so that the elevation crank is free to rotate. (See figure 4.) The base of the saw must be mounted flush to a flat surface on the work bench to prevent distortion of the saw base. The nuts, screws, and washers which attach the wooden shipping skids to the saw base may be used to secure the saw base to the work bench.

**NOTE:** The seven basic "steps" that follow are essential in order to insure correct alignment of saw.

**WARNING:** Make sure power cord is not plugged into an electrical outlet when working on the saw.

#### STEP ONE — INSTALLATION OF FRONT TABLE

1. Place the large table board upside-down on floor. The bottom side has a notch (cutout) for clearance of elevation crank. (See figure 4.) Distinguish between the five through-bored (leveling screw) holes and the seven counterbored holes. Drive T-nuts into the five through-bored holes. (See figure 5.)
2. Place the large table board on channels with cutout table notch forward and down as shown in figure 4.
3. Align the counterbored holes with matching holes in the channels. Place a 1/4" flat washer and a 1/4-20 x 1" machine screw in each of the six counterbored holes located above the channels. Use a 1/4-20 x 1-1/4 machine screw in the counterbored hole at the center of table board.
4. Attach lockwashers and nuts to the six screws in the channels. **Do not tighten these screws at this time.**

#### STEP TWO — CHECKING FOR LOOSENESS OF COLUMN TUBE IN COLUMN SUPPORT

1. Tighten arm latch handle (20, figure 24).
2. Grasp arm latch handle (20, figure 24) with one hand and hold fingers of other hand at parting line between column tube and column support. (See figure 6.) Apply gentle side force to the radial arm in opposing directions. Any looseness between column and column support, (indicated by arrow in figure 6) can be felt with fingers.
3. If looseness can be felt, at point indicated by the arrow in figure 6, perform operations outlined in instructions that follow:

**NOTE:** Before attempting to adjust the column tube key, the function of this adjustment should be understood. Figure 7 shows a sectional view through the column tube support (looking downward) at this location. By

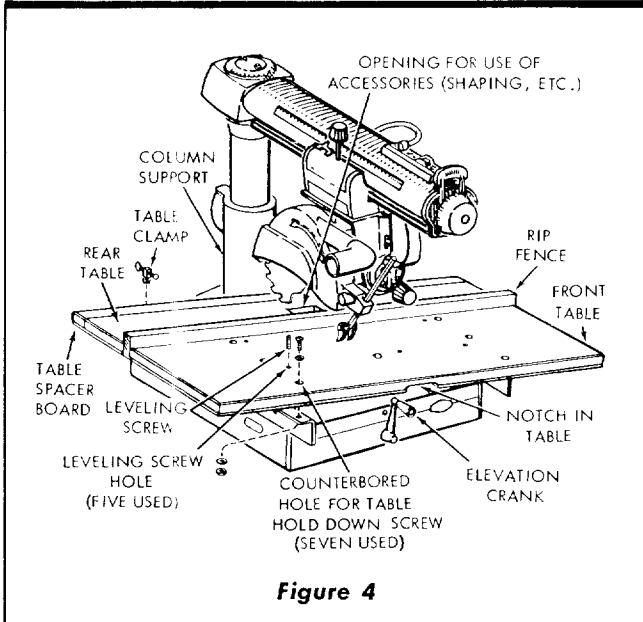

Figure 4

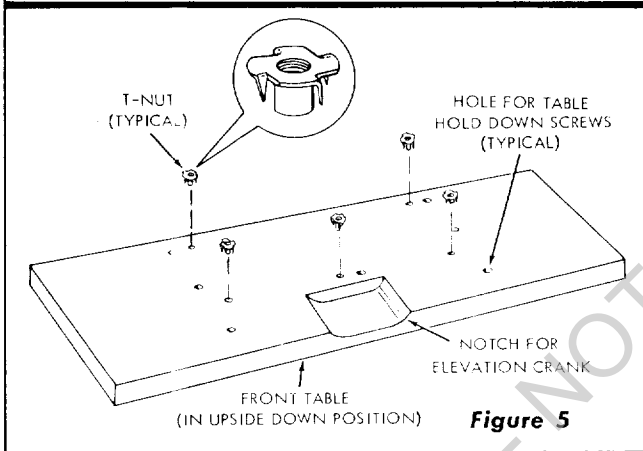

Figure 5

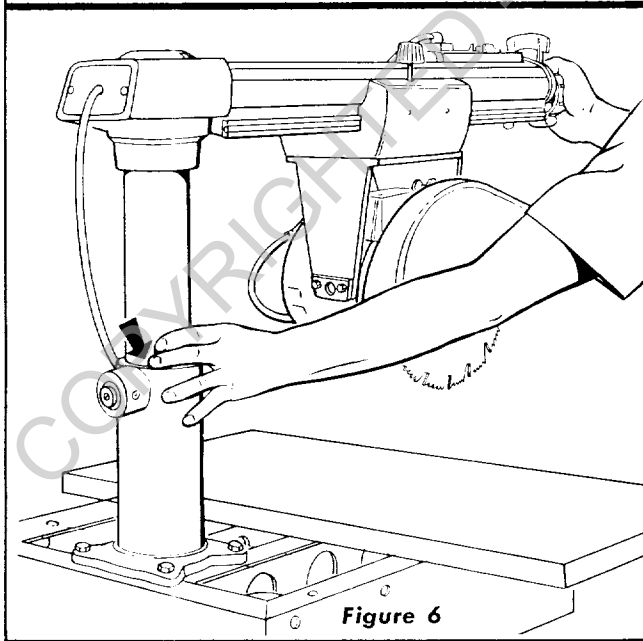

Figure 6

loosening the left-hand set screw and tightening the right-hand set screw the column tube key will be forced tighter into the column tube keyway. Conversely, loosening the right-hand set screw and tightening the left-hand set screw, the column key will be retracted out of the column tube keyway. The set screw in outer end of column tube key must be loosened while adjustment is being made and tightened with medium firmness after adjustment is completed. This screw applies pressure on the Nylon friction plug and provides smoother elevation movement of column tube. This set screw should be tightened to provide maximum smoothness of operation. **Right and left positions are given with operator facing the saw — standing in front of saw table.**

- a. Loosen set screw in center of column tube key. (See figure 7.)
- b. Loosen left-hand set screw 1/4 turn. (See figure 7.)
- c. Tighten right-hand set screw. (See figure 7.)
- d. Tighten left-hand set screw. (See figure 7.)
- e. Turn elevation crank to raise and lower radial arm. (See figure 8.) If too tight, loosen right-hand set screw (figure 7) slightly and check again for smooth operation. When correct, tighten left-hand set screw.
- f. Tighten set screw in center of column tube key (figure 7) until smoothest operation is obtained.
- g. **Lock the yoke clamp handle (7, figure 24) and bevel lock knob (15) securely.**

### STEP THREE — SQUARING THE CROSS CUT

1. Loosen the arm latch handle (figure 9) 1/4 turn. Make sure the yoke clamp handle and bevel lock knob are tight.
2. Pull the arm latch lever outward and move radial arm approximately 10° to the right. Release arm latch lever and move radial arm into the 0° (index) position. Do not bump or jar the arm. Push the arm latch handle, or arm latch lever solidly with palm of hand in order to seat arm lock pin in the arm latch. (Refer to figure 25.)
3. Tighten arm latch handle. (Refer to "PRECISION INDEXING" under "Proper Operating Procedures" for detailed instructions on indexing the radial arm.)
4. Place a framing square on the table as shown in figure 9 and position the saw and square until the leg of the square just contacts a tooth of the saw blade. (Position "A", figure 9.) Mark this tooth with crayon or chalk.
5. When the carriage is moved back and forth on the radial arm, the saw tooth "A" should just touch the square at all positions. If saw tooth "A" does not touch the square at all points, make the following adjustments.
  - a. If saw tooth ("A", figure 9) moves away from the square when moving the blade from the rear toward the front of the table, tap the right-hand front edge of the table.
  - b. If the saw tooth ("A", figure 9) moves into the square when moving saw from the rear to the front of saw table, tap the left-hand front edge of table.
  - c. Recheck . . . and, if correct, tighten all table hold down screws.
6. In extreme cases, the above adjustment procedure may not be sufficient due to rough handling during shipment. Make the following adjustment only after tightening the

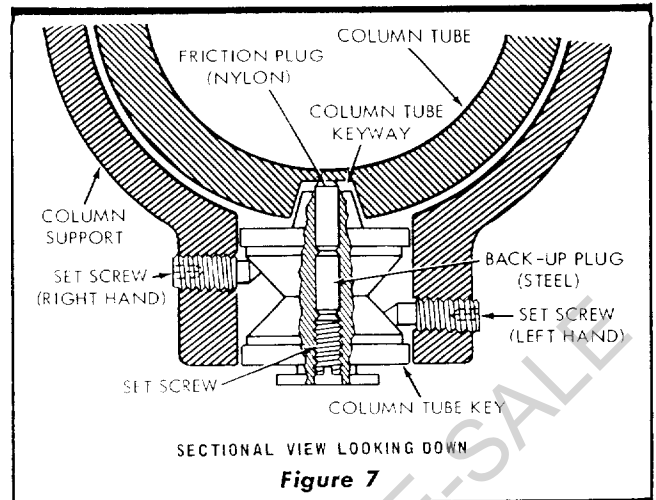

Figure 7

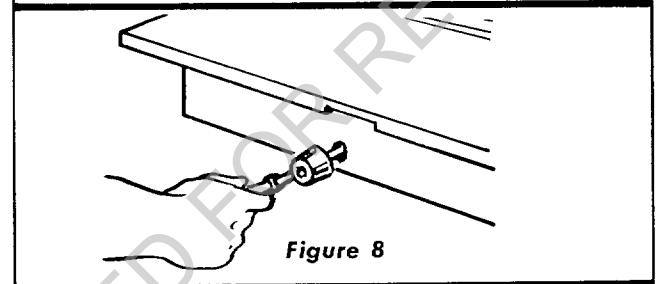

Figure 8

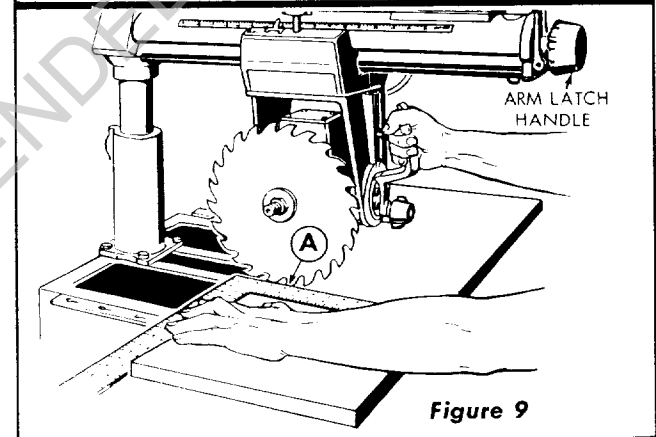

Figure 9

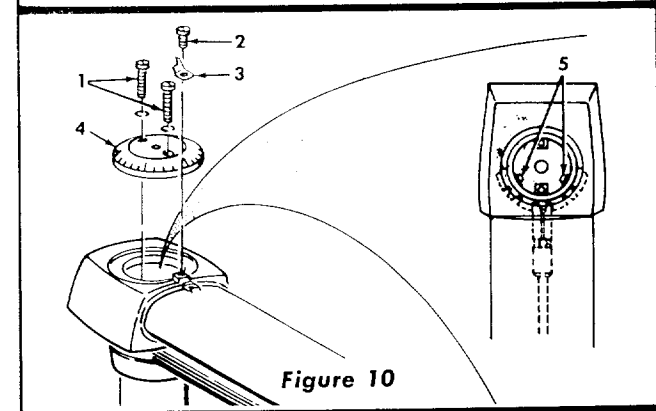

Figure 10

table screws and the cross-cut cannot be squared according to the preceding adjustment routine.

- a. Remove three screws (1 and 2, figure 10), miter-scale indicator (3) and radial arm cap (4).
- b. Turn the arm latch handle (figure 9) one-quarter turn counterclockwise but do not pull it out.
- c. Loosen (do not remove) two hex-head screws (5, figure 10) located inside the column tube.

- d. Move radial arm slightly in the proper direction to make saw tooth ("A", figure 9) follow edge of square when the saw blade is moved in and out in a "cross-cut" manner.
- e. Re-tighten the hex head screws (5, figure 10) and arm latch handle (See figure 9).
- f. Recheck travel of blade tooth ("A") with the square.
- g. After the cross-cut has been accurately squared, install the radial arm cap (4, figure 10), miter-scale indicator (3) and screws (1 and 2). Set the indicator (3) at 0° position.

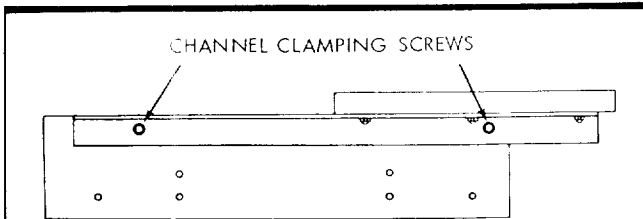

Figure 11

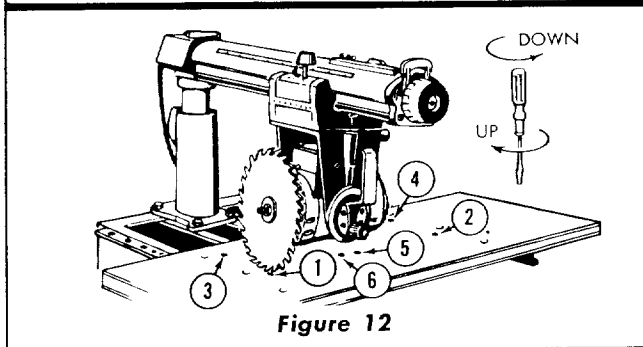

Figure 12

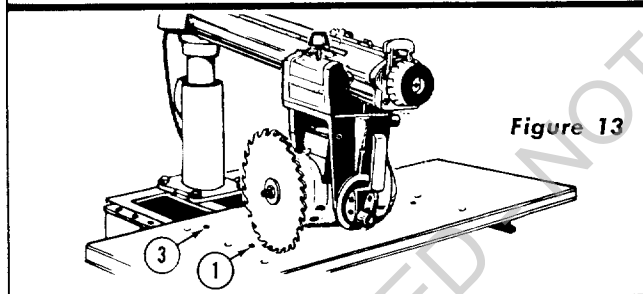

Figure 13

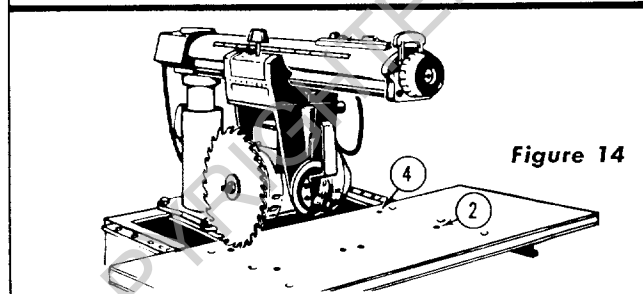

Figure 14

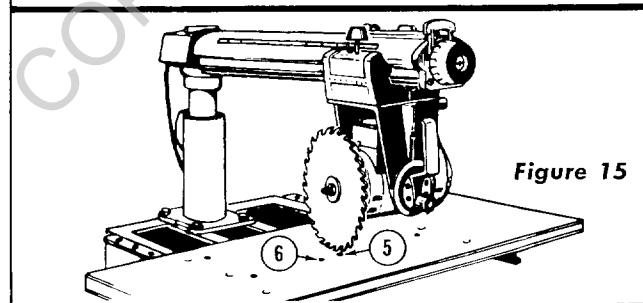

Figure 15

#### STEP FOUR — ADJUSTING THE TABLE PARALLEL TO THE RADIAL ARM

**NOTE: DO NOT USE A CARPENTERS LEVEL**

1. Remove the saw guard.
2. Insert a set screw (leveling screw) into each of the five leveling, T-nuts. (See figure 5.) Insert screws from the top side until they just touch the top of the base.
3. Loosen channel clamping screws (figure 11) at both left and right sides of the base. Re-tighten to finger tightness for adjustment of table.
4. Loosen arm latch handle (20, figure 24) enough to obtain free movement of radial arm, release arm latch lever (1, figure 24) and loosen carriage lock knob and move it to points (1, 2, 3 and 4, figure 12) to find at which of these points the blade first touches the top of the table.

**NOTE:** Actual contact with table top can be easily determined by rotating saw blade by hand and listening for a light "pinging" sound as the carriage is lowered.

5. The high point must be at one of the front screw holes before continuing the paralleling procedure. If high point is not at the front, adjust the screw at point (1, figure 12) so the high point is created at the front near point 1. Raise the blade slightly to pick-up a "pinging" sound at this new high point.

**NOTE:** Do not change elevation of the blade during the remainder of the paralleling operation.

6. Move the blade to the back of table, directly behind the high point. Raise the table to blade height at this point by adjusting the screw at point (3, figure 13) on left-hand side of table. Tighten the channel clamping screws at front and back of base on the left-hand side. (See figure 11.)
7. Return the blade to front of table and make a slight adjustment of the screw in this area, if necessary.
8. Swing the blade to front of table on right-hand side. Adjust screw at point (2, figure 14).
9. Move blade to back of table. Raise the table to blade height at this point by adjusting the screw at point (4, figure 14). Tighten channel clamping screws at front and back of base on right-hand side.
10. Return the blade to front of table and make a slight adjustment of the screw in this area if necessary.
11. Move the saw blade to all four screw positions to recheck for proper paralleling of table. (Points 1 through 4, figure 12.)
12. Move the saw blade to center of table. If the table is low at this point, raise it by adjusting the screw (point 5, figure 15). It may be necessary to back off the screw (6) to provide proper clearance.
13. If the table is high at the center, lower it by tightening the screw (6). When the table is adjusted parallel to the radial arm, rotate the set screw (5) clockwise until it bottoms on the base. This will serve as a lock for the adjustment of screw (6).
14. Place the rip fence in vertical position behind front table board. (See figure 4.)
15. Place the rear table behind the rip fence, with the cutout forward (next to rip fence).

**NOTE:** The opening in rear table is used when shaping, or performing any operation where the particular cutter must extend below table top level.

16. Place the table spacer behind the rear table.

17. Install the table clamps at locations shown in figure 4 and tighten them securely against the edge of table spacer.

#### STEP FIVE — SQUARING THE SAW BLADE TO THE TABLE TOP

1. Place the edge of a framing square on the table top and against the saw blade as shown in figure 16.
2. When the saw blade is square to the table top, no light will be visible between the square and face of saw blade. Do not allow the square to rest against a tooth of the saw. If light is visible between the square and face of saw blade (with square leg held firm against the table top), perform the following adjustments.
  - a. Using a 1/4-inch hex "L" wrench, loosen just slightly the four socket-head screws (2, figure 16).
  - b. Tilt the motor until the saw blade is square with the table top as shown in figure 16. Then, while holding the square firmly against the saw blade and table top, apply pressure against lower part of saw blade with the thumb until approximately 1/32-inch clearance exists between the square and lower edge of saw blade. This is to compensate for the possible slight shifting of the motor while screws (2) are being tightened.
  - c. Tighten the socket head screws (2, figure 16).
 

**NOTE:** It may be necessary to perform more than one trial operation before the saw blade remains perfectly square with table top after tightening screws.
  - d. Recheck for blade squareness with table top.
  - e. The indicator (3, figure 16) should read 0° on the bevel index scale. If not, loosen the indicator attaching screw, adjust indicator to zero and tighten screw securely.

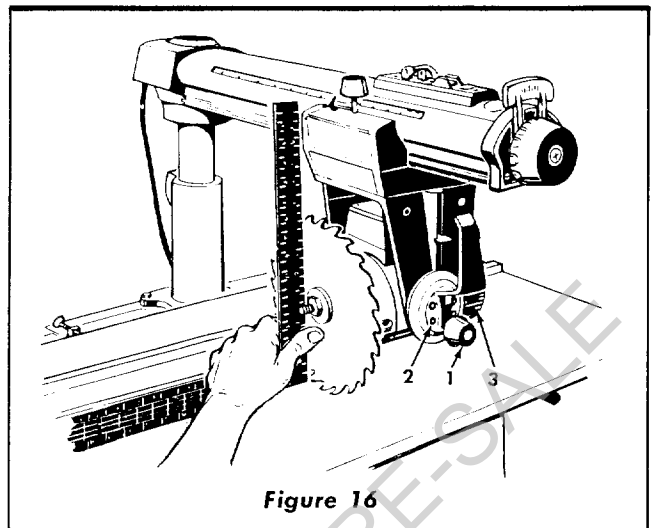

Figure 16

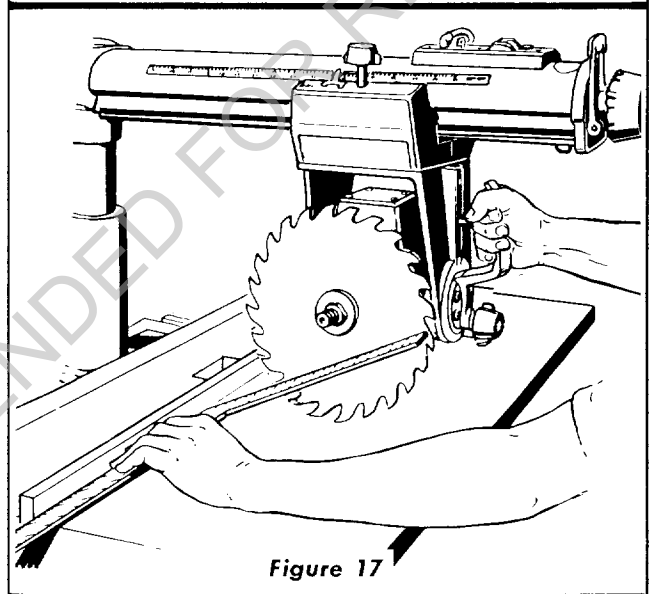

Figure 17

#### STEP SIX — CHECKING THE SAW BLADE FOR HEEL (LEFT AND RIGHT)

1. Place a square against the rip fence and the saw blade as shown in figure 17. The long leg of the square must be held firmly against the rip fence and the short leg must not touch any of the teeth on the saw blade.
2. If a gap exists between the saw blade and the square, one of two types of "heel" exists. The two types of "heel" are illustrated in views "A" and "B", figure 18. To correct for either type of "HEEL" condition, proceed as follows:
  - a. Remove the left-hand carriage cover (1, figure 19).
  - b. Loosen the yoke clamp handle (2).
  - c. Loosen (slightly) the two hex-head machine screws (3).
  - d. Rotate the yoke until the gap between the saw blade and square is eliminated.
  - e. Lock the yoke and tighten the two hex-head machine screws (3).
  - f. Recheck for "heel" after tightening screws, and make corrections if necessary.
  - g. Install carriage cover (1, figure 19).

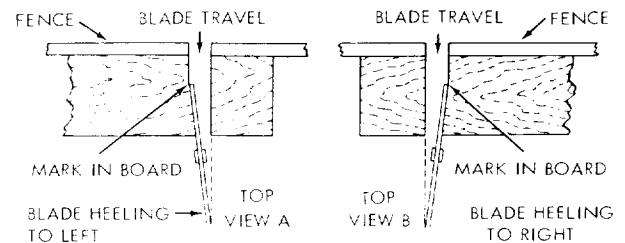

Figure 18

#### STEP SEVEN — DOUBLE CHECK SQUARING OF SAW

1. Recheck for correct adjustment of the saw by performing "STEPS THREE, FIVE and SIX".
2. If the cross cut is not perfectly squared, proceed with "STEP THREE" (paragraphs 5 and 6), and "STEP SIX" if a correction is required.

**NOTE:** If after making all adjustments outlined in STEPS "ONE" through "SEVEN," refer to Trouble Shooting Charts for any existing problems.

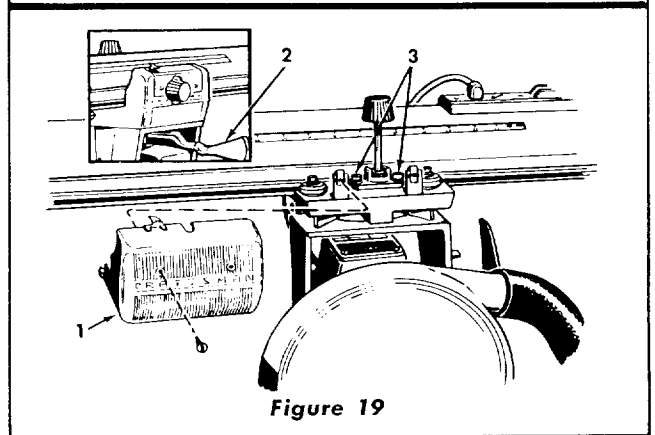

Figure 19

## ATTACHING AND DETACHING THE SAW BLADE

1. Locate the motor carriage assembly midway on radial arm and tighten carriage lock knob (5, figure 24).
2. **REMOVAL** (See figure 20.)
  - a. Place the open-end shaft wrench on flats of shaft on inside of saw blade. Allow end of wrench to rest on saw table.
  - b. Using the box-end arbor wrench, loosen the shaft nut.
 

**NOTE:** The motor shaft has left-hand threads.
  - c. Remove shaft nut, collar, saw blade and second collar.

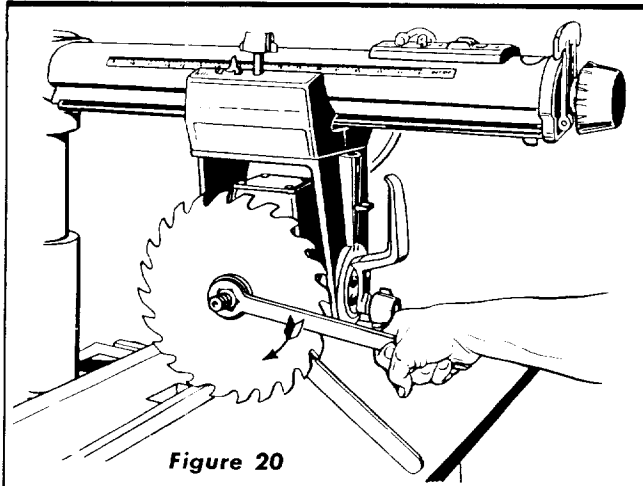

Figure 20

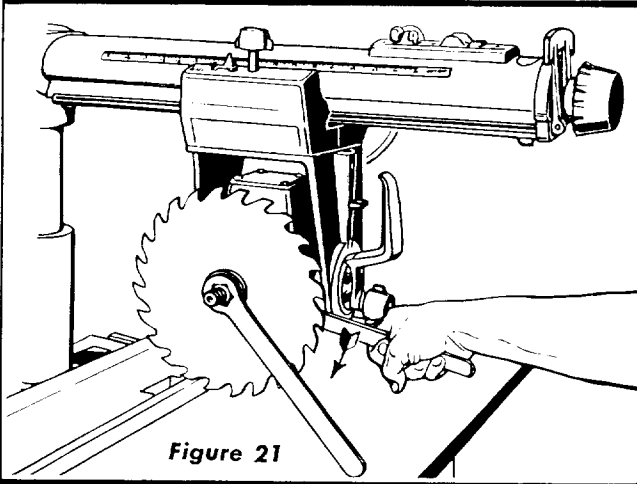

Figure 21

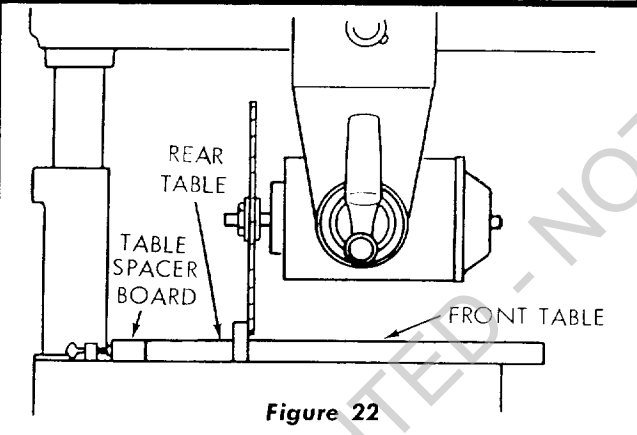

Figure 22

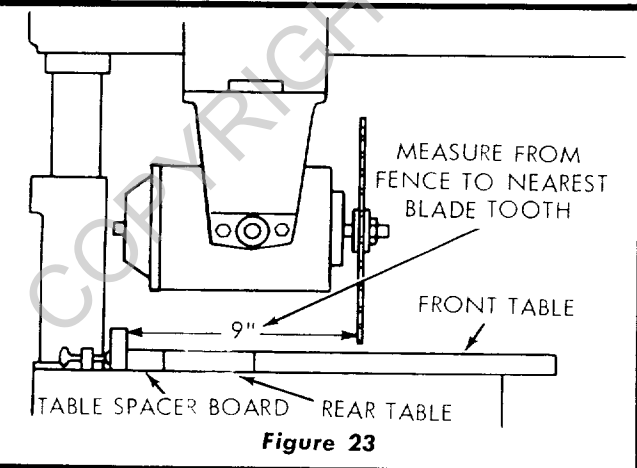

Figure 23

3. **INSTALLATION** (See figure 21.)
  - a. Place inside collar on motor shaft, with flange next to saw blade.
  - b. Install saw blade, outside collar and nut.
 

**NOTE:** Make sure the larger (flange) face of each collar is next to saw blade.
  - c. Place box-end arbor wrench on shaft nut and let it rest on saw table.
  - d. Use open-end shaft wrench on flats of shaft and tighten by pushing downward as shown in figure 21.

## ADJUSTMENT OF RIP SCALE INDICATORS

**NOTE:** The rip scales and pointer are intended to be used for quick settings. For greater accuracy, take direct measurement between blade and fence.

When the fence is in its normal position (next to the front table), index the yoke 90° from the cross-cut position so that the blade is between the motor and the fence. Lock the yoke.

Move the motor along the radial arm until the blade, when spun by hand, just touches the front face of the fence (see figure 22). The rip-scale indicator (4, figure 24) on the right-hand side of radial arm should now read 0-inches. If not, shift the position of the indicator to read 0-inches.

**NOTE:** With the saw blade and fence in the position shown in figure 22, the upper portion of the "In-Rip" scale is used. If the fence is moved to the extreme rear position, the lower portion of the "In-Rip" scale is used.

The "Out-Rip" scale indicator on the left-hand side of radial arm is adjusted in essentially the same manner as the "In-Rip" indicator, except the blade should be positioned as in figure 23. With 9-inches measured between the fence (when in full rear position) and face of saw blade, the indicator should be positioned to read 9-inches on the lower portion of the "Out-Rip" scale.

**NOTE:** With the saw blade and fence in the position shown in figure 23, the lower portion of the "Out-Rip" scale is used. If the fence is moved to normal position (at the rear of front table) the upper portion of the "Out-Rip" scale is used.



# OPERATING CONTROLS

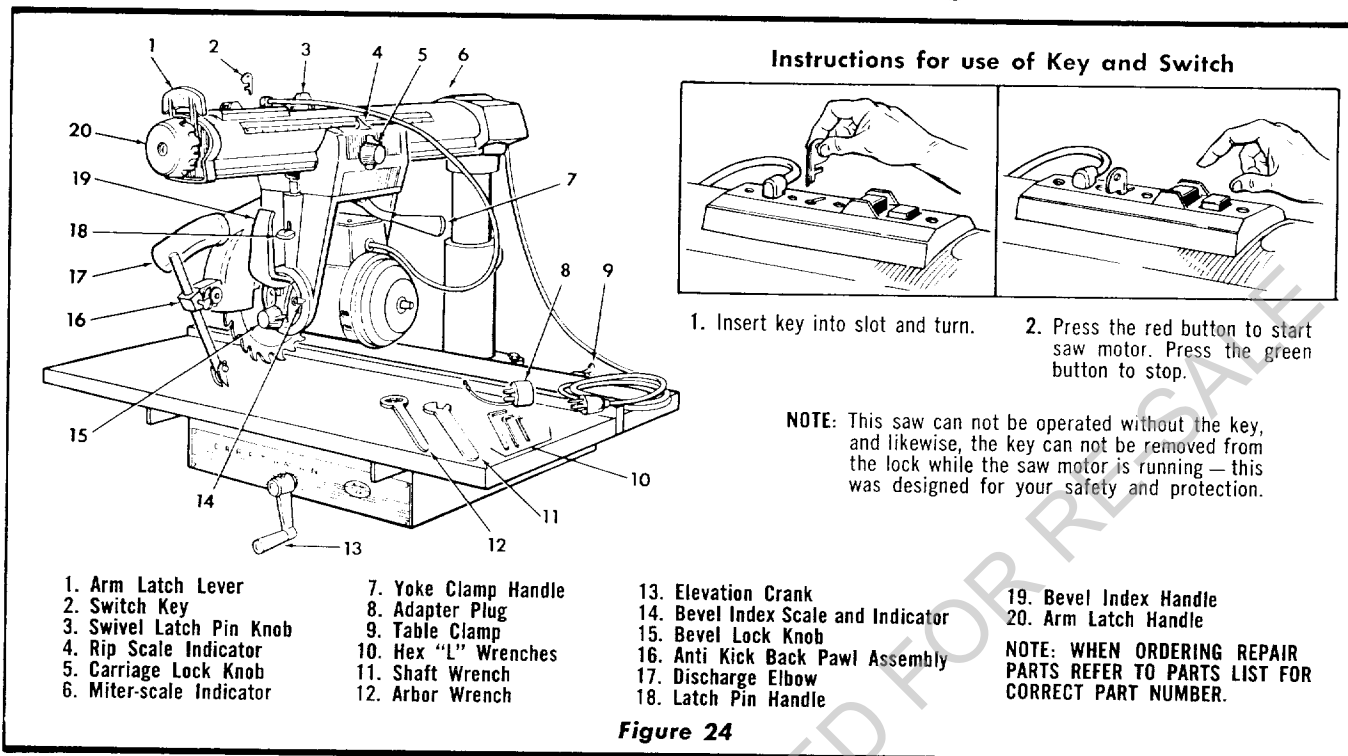

## COLOR CODING

In order to simplify operation of the saw, the various basic operating functions are keyed to their respective controls with color discs (or paint) directly on the controls. These colors are as follows:

1. **RED** — Radial arm indexing and locking — colors located on arm latch handle (20, figure 24) and miter scale indicator (6).
2. **YELLOW** — Bevel indexing and locking — colors located on bevel lock knob (15, figure 24), latch pin handle (18) and bevel index indicator (pointer) (14).
3. **ORANGE** — Swivel indexing and locking — colors located on swivel latch pin knob (3, figure 24), yoke clamp handle (7) and yoke.

The operator should become familiar with these control systems before attempting any projects with the saw.

**RAISING AND LOWERING THE RADIAL ARM** is accomplished by the elevation crank (13, figure 24). One complete turn of this handle will raise or lower the radial arm  $\frac{1}{8}$ ".

**LOCKING THE CARRIAGE TO THE RADIAL ARM** is accomplished by the carriage lock knob (5, figure 24). Turn the knob clockwise to lock; counterclockwise to unlock.

**ANGULAR MOVEMENT AND LOCKING OF THE RADIAL ARM** are controlled by the arm latch lever (1, figure 24, and the arm latch handle (20). The radial arm can be rotated  $360^\circ$  and locked in any position. The arm is unlocked from any position by a slight counterclockwise rotation of the arm latch handle and is locked in any position by rotating the arm latch handle clockwise until tight. The radial arm has positive stops at  $0^\circ$  and  $45^\circ$  left and right, and is released from these index positions by unlocking the arm latch handle and pulling out the arm latch lever (1).

For most positive and accurate settings at the index positions, the following is recommended:

1. If the radial arm is already indexed, turn the arm latch

handle (20, figure 24) just  $\frac{1}{4}$  turn **counterclockwise from the locked position**, pull out the arm latch lever and move radial arm off the index position. Release the arm latch lever.

2. Move the radial arm into the index position (do not bump or jar) and push on the handle or the arm latch lever solidly with the palm of the hand. (See figure 25.) This is very important as it insures proper seating of the arm lock pin in the arm latch, thus always returning the arm to the correct cross-cut ( $0^\circ$ ) position.
3. Lock the radial arm by turning the arm latch handle clockwise until tight.

**CAUTION:** When moving the radial arm in any direction beyond  $45^\circ$  left or right, always pull out the arm latch lever (at end of radial arm) to prevent damaging the arm lock pin. If damage occurs, the radial arm will not index properly at  $0^\circ$  and  $45^\circ$  left or right.

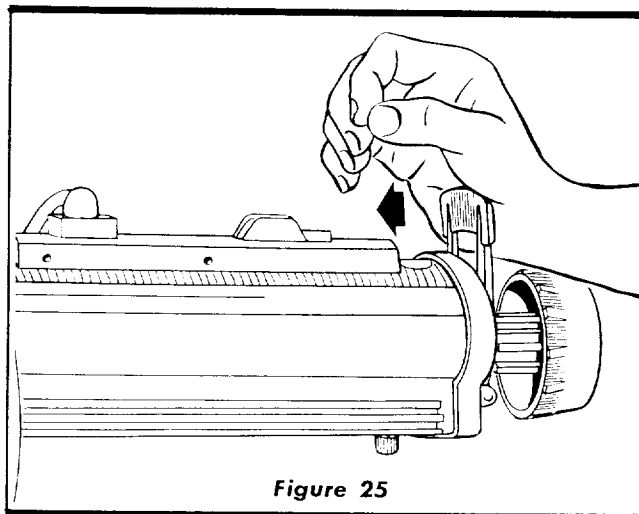

**MOVEMENT AND POSITION OF THE MOTOR IN THE YOKE** are controlled by the latch pin handle (18, figure 24) and bevel lock knob (15). The bevel scale indicates the angular position of the motor with respect to the horizontal from 0° to 90° in either vertical position. The latch pin handle automatically indexes the motor at 0°, 45°, and 90° up and down. Lift to release. At any other position, the latch pin handle is not engaged. The bevel lock knob locks the motor to the yoke when the motor is in any position. Locking is clockwise; unlocking is counterclockwise.

**MOVEMENT AND POSITION OF THE YOKE** are controlled by the swivel latch pin knob (3, figure 24) and the yoke clamp handle (7). The swivel latch pin automatically indexes the yoke at each 90° position and two 45° positions. Lift to release. The yoke clamp

handle locks the yoke to the carriage in any position. Pull to release. Push to tighten. When "In-Ripping" it may be desirable to have more free table in front of the saw blade than is obtainable when the radial arm is at the 0° position. With the blade in the normal cross-cut position index the radial arm to 45° left and lock it. Then loosen the yoke clamp handle and index the yoke 45° clockwise. Reclamp the yoke clamp handle. The added free table space is now to the right of the blade and ripping should be done from the right side of the table. The reverse is also true for "Out-Ripping" by indexing the radial arm 45° right and indexing the yoke 45° counterclockwise. The added table space is now to the left of the blade and ripping should be done from the left side of the table.

**CAUTION:** Under these two conditions the In-Rip and Out-Rip scales cannot be used.

## PROPER OPERATING PROCEDURES

**PRECISION INDEXING** — Experienced operators of precision equipment, such as this Craftsman Saw, normally acquire the habit of indexing the machine in one direction only whenever a new setting is made in preparation for a different operation. For example: When moving the radial arm to a new position it is advisable to move it slightly past the desired index position then move it back slowly and carefully to latch and lock it. Swivel indexing and bevel indexing can be accomplished in the same manner. This technique tends to neutralize any stresses imposed upon saw components and contributes to the high degree of accuracy this saw is capable of producing when operated expertly.

**DRESS PROPERLY** — Operation of the saw is simple, safe and easy—when properly done. Always be alert. Do not wear a tie or other loose articles. Keep long sleeves down with cuffs fastened or wear short sleeves. **NEVER STOP BEING CAREFUL.** One moment of inattention can cost you a painful injury.

**AVOID AWKWARD HAND POSITIONS** — Do not get hands into a position in which a sudden slip can cause them to move into the saw blade. **NEVER OPERATE THE SAW WITH THE ARMS IN A CROSSED POSITION.** Never hold work on right side of blade with left hand while pulling saw with the right hand. Do not attempt free-hand cross-cutting. Use a push stick when hand gets too close to the blade in a ripping position.

**DISCONNECT INPUT CABLE** from power supply when adjusting the saw from one working position to another.

**NEVER TWIST WORK** — Twisting work will bind blade and cause a kickback.

### SAFETY PRECAUTION

The motor is shipped with a shaft cap threaded onto the stub end of the motor shaft. (See Parts List.) When this shaft end of the motor is not being used, this cap should always be attached.

## ADJUSTMENTS TO COMPENSATE FOR WEAR

Even though the finest materials and precision workmanship have been used to minimize wear it is reasonable to expect that some wear will eventually occur. Adjustments have been built into your Craftsman saw to reduce or eliminate this wear.

### ELIMINATING LOOSENESS BETWEEN COLUMN TUBE AND COLUMN SUPPORT

This operation is explained fully in "STEP TWO — CHECKING FOR LOOSENESS OF COLUMN TUBE IN COLUMN SUPPORT."

### YOKE CLAMP HANDLE ADJUSTMENT

The normal locking position of the yoke clamp handle (1, figure 26) is approximately midway between the two sides of the yoke.

When the handle moves considerably to the rear, or strikes the yoke before locking, the handle may be adjusted as follows:

1. Remove saw guard and blade.
2. Set yoke clamp handle to Position "A", (figure 26), which is just slightly ahead of the mid-position of handle.
3. Remove the carriage stop screw and lockwasher from the underside of radial arm near the front end of the arm. (See figure 28.)

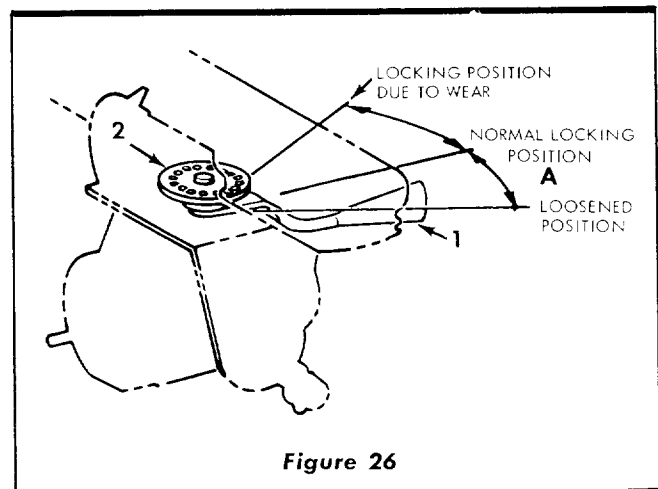

Figure 26

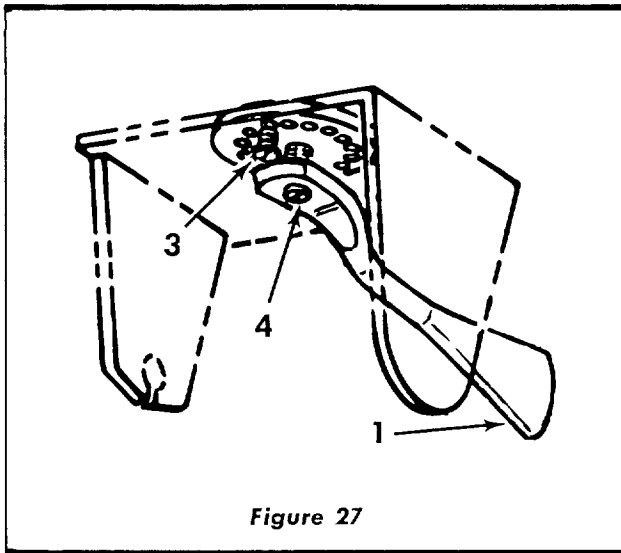

Figure 27

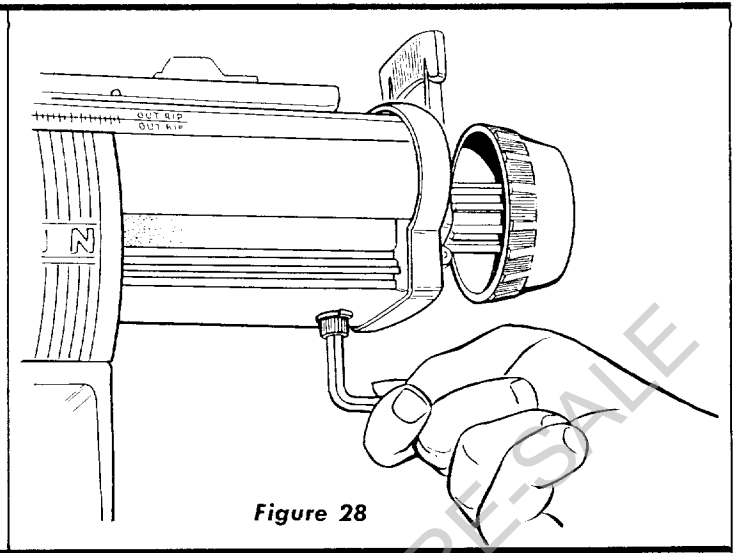

Figure 28

4. Grasp the motor and carriage assembly and move it carefully off end of radial arm. Remove circular cardboard on top of yoke clamp assembly.

**CAUTION:** When removing the motor and carriage assembly from radial arm, be sure to hold the assembly parallel to the arm until all bearing rollers are free of their tracks. If the assembly is allowed to tilt after the forward rollers are free, the adjustment of rear rollers will be altered and there is also danger of impressing dents into the track. These same precautions should be taken when installing the motor and carriage assembly on the radial arm.

5. Rest the motor and carriage assembly on saw table.
6. Remove the lock screw (3, figure 27).
7. Using a screwdriver or similar tool, rotate the yoke clamp assembly (2, figure 26) clockwise (when looking down) until the next hole will line up with the lock screw (See figure 29). Usually, rotating the yoke clamp assembly one hole will correct this adjustment. However, in some cases it may be necessary to rotate it two holes.
8. Make sure the hole in yoke clamp assembly (2, figure 26) lines up with lock screw hole and install and tighten lock screw (3, figure 27).
9. Install motor and carriage assembly on radial arm. (See "CAUTION" under preceding paragraph step 4.)
10. Install carriage stop screw and lockwasher in radial arm. (See figure 28.)

The circular cardboard, removed in preceding paragraph 4, need not be installed as it is used only for manufacturing purposes.

### CARRIAGE BEARING ADJUSTMENT

To test for looseness in carriage ball bearings (between bearings and tracks in radial arm), lock yoke clamp handle, grasp the motor and carriage assembly firmly and apply a firm rocking motion. If looseness exists, the two bearings on **left-hand side** of radial arm must be adjusted. The two bearings on right-hand side of arm are attached to the carriage with regular hex-head screws and are not adjustable. The two bearings on left-hand side of arm are attached to carriage with eccentric screws. (See figure 30.)

1. Remove left-hand carriage cover (2, figure 31).

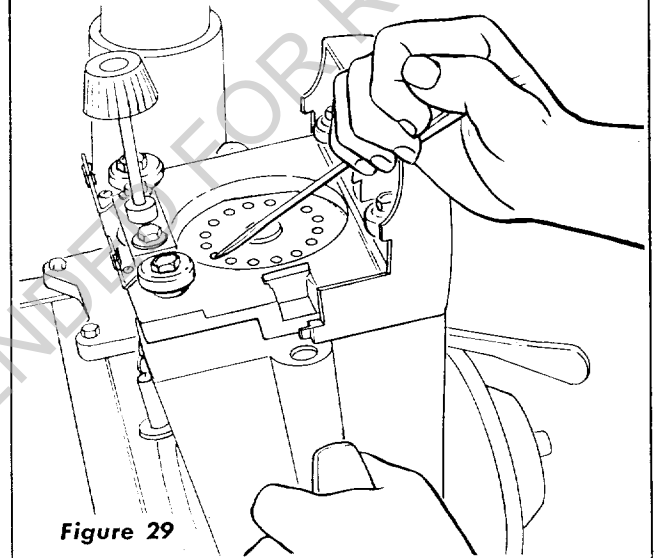

Figure 29

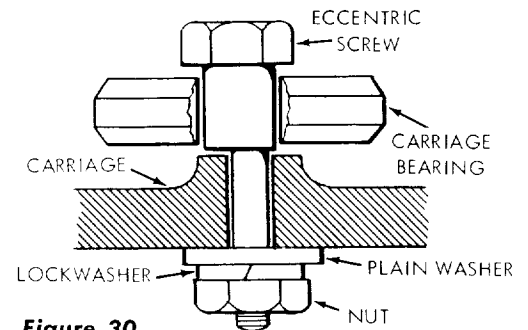

Figure 30

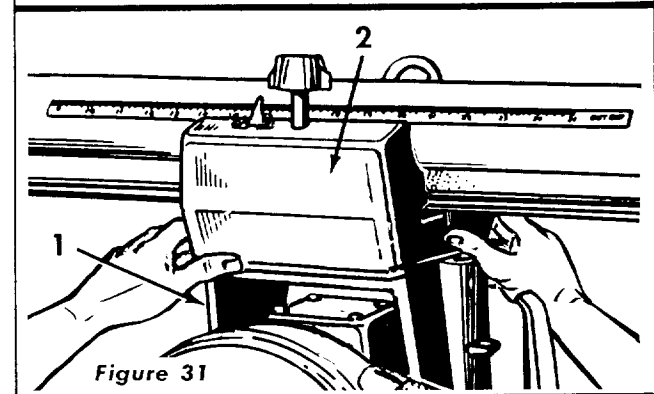
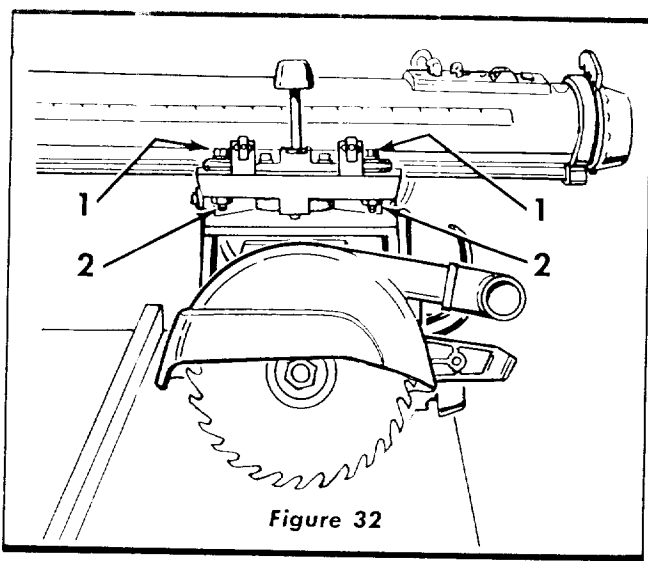

Figure 31



2. Loosen nuts (2, figure 32) just enough to permit eccentrics to turn. (See figure 30.)
3. Turn adjusting screws (1, figure 32) a partial turn left or right as required to take up looseness.
4. Hold head of screw (1, figure 32) in position established in preceding step and tighten nut (2) on underside of carriage.
5. Correct adjustment exists when there is no play between the carriage and radial arm, and yet the carriage moves freely.
6. Install carriage cover (2, figure 31).

**NOTE:** It will probably be necessary to recheck steps "THREE, FOUR and FIVE" under "ASSEMBLING AND ADJUSTING YOUR SAW" after adjusting the carriage bearings.

## STANDARD SAW OPERATIONS

### CROSS-CUTTING

Cross-cutting is the sawing of wood across the grain. Planks are milled with the grain running the length of the plank. If a straight cross-cut is desired, the board is placed on the saw table against the fence so that the grain is parallel to the fence. (See figure 33.)

**NOTE:** When cross-cutting normal pieces of lumber, the long end of the board should be placed to the left of the saw blade as the board is normally held by the left hand during operation. The saw is pulled through the stock—not pushed.

The radial arm must be positioned at 0° as indicated by the radial arm position indicator. The arm latch handle must be indexed and tightened. (Refer to paragraph entitled "Angular Movement And Locking Of The Radial Arm".) The yoke must be indexed at the 0° position, making the saw blade perpendicular to the rip fence, and the yoke clamp handle placed in the locked position. The bevel index handle must be positioned at 0°, as indicated by the bevel scale, and locked. Turn the elevation crank to lower the saw until the blade teeth are approximately 1/32" below the table surface and ride in the saw slot made when performing the "PRELIMINARY CROSS-CUT AT THE 0° POSITION". Push the saw carriage to the rear of the radial arm so the blade is behind the rip fence. Adjust the anti-

## LUBRICATION

Your saw is a fine machine and should be given the best of care. If kept clean and properly lubricated, it will give many years of trouble-free service. Before describing the various points which may periodically require lubrication, IT IS MORE IMPORTANT TO FIRST MENTION THE VARIOUS SPOTS WHICH SHOULD NOT BE LUBRICATED.

### NO LUBRICATION REQUIRED

- Do not lubricate carriage ball bearings.
- Do not lubricate the motor bearings. These are sealed ball bearings and require no added lubrication.
- Do not lubricate between radial arm cap and radial arm.

### PERIODICALLY LUBRICATE THESE POINTS

Use SAE No. 10-30 Auto Engine Oil and refer to Parts List for locations.

Apply a few drops of oil along the swivel latch pin only if the pin has a tendency to stick. Remove the left-hand carriage cover and use oil sparingly to prevent it from getting on the ball bearings or races.

A light film of oil can be wiped on the face of the column tube and keyway to lubricate the fit between column, key and column support.

Apply a few drops of oil to the bearing surfaces of the elevation crank shaft assembly. An oiling hole is provided in the elevation shaft bearing bracket to facilitate the lubrication of the rear bearing support.

The thread on the elevation shaft assembly can be lubricated through the oiling hole in the center of the radial arm cap.

**CAUTION:** Excessive oil at any location will attract dust particles and sawdust.

kickback pawl assembly so it clears the board to be cut. Press the switch key "On" to start the saw motor. Hold the board firmly against the rip fence with the left hand and grasp the bevel index handle with the right hand. The cut is then made by pulling the carriage forward until the saw blade cuts through the work. When the cut is complete, the saw should be returned to the back of the radial arm and the switch turned "Off". **When more experience is gained by using the saw, it will be noticed that when pulling the saw toward you during cross-cutting, the saw blade tends to feed itself through the work due to the rotation of the blade and the direction**

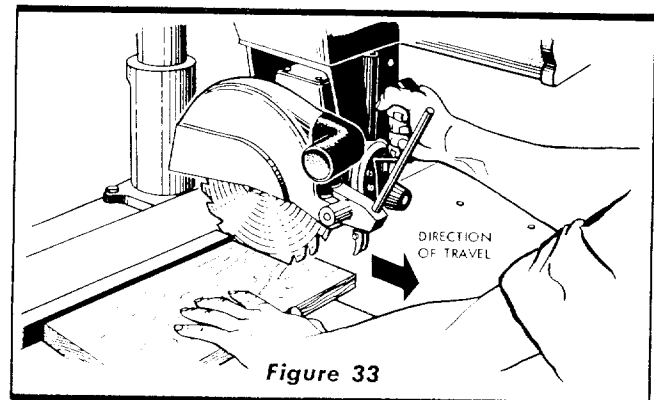

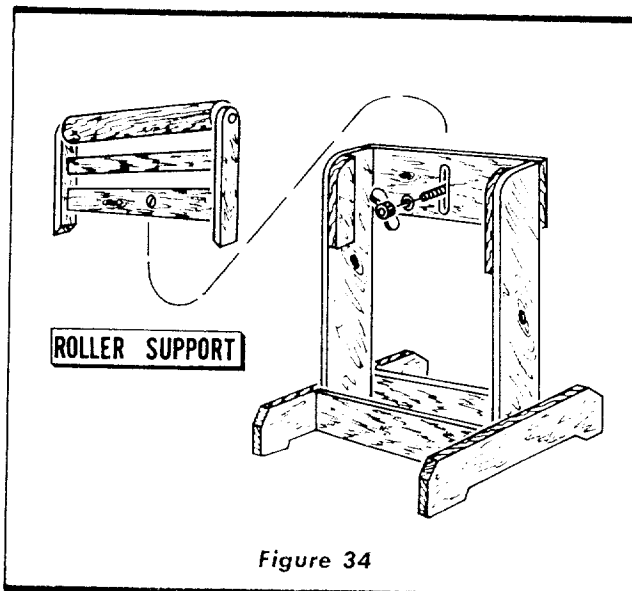

Figure 34

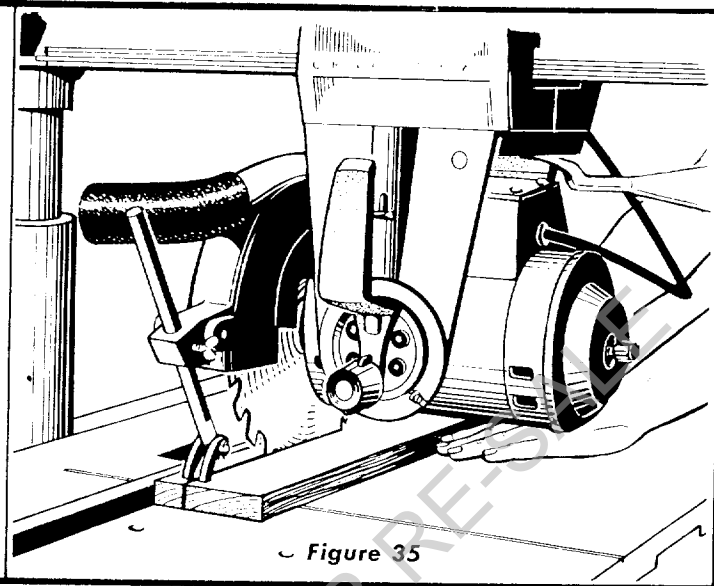

Figure 35

of feed. Therefore, the operator should develop the habit of holding his right arm straight from the shoulder to the wrist. After this method is used a few times the operator will find that it is necessary to roll or rotate the body from the waist up. If this method is followed, it will become apparent that very little effort is required on the part of the operator to move the saw blade through the work, and in most cases, the right arm is used merely to control the rate of feed of the saw through the board. It will also be found that when cross-cutting a thick board it will be necessary to retard movement of the saw through the work. By holding the right arm (right hand normally grips the saw handle) straight, the operator can easily control the rate of feed, thus preventing the saw blade from overfeeding and stalling the saw motor. This must be avoided whenever possible. In some cases it may become necessary to cross-cut long boards which extend over the saw table on one, or both sides. This can cause buckling of the board and bind the saw during the cut. To eliminate this condition the ends of the board should be supported. Figure 34 illustrates a typical support which can be made and used to facilitate cross-cutting of long lumber.

### RIPPING

Ripping is the sawing of wood with the grain. It is always done with the help of the fence as a guide to position and maintain the work at the correct width for the cut. Because the work is pushed along the fence, it must have a reasonably straight edge to make sliding contact with the fence. Also, the work must make solid contact with the table so that it will not wobble or rock. Provide a straight edge, even if this means temporary nailing of an auxiliary straight edge board to the work. If work piece is warped, turn the hollow side down.

Use of the saw guard is always recommended; and the anti-kickback pawl assembly should always be used in both ripping operations. Before ripping and after the saw has been positioned prior to cutting, the saw guard and anti-kickback pawl assembly must be properly adjusted. Loosen the wing nut holding the guard to the motor and lower the nose of the guard to within  $\frac{1}{8}$ " above the top surface of the board to be cut. Retighten the wing nut securely.

**CAUTION:** The nose of the guard refers to that end of the guard which is opposite to the end which mounts the anti-kickback pawl assembly. Always rip from the nose of the guard. See Warning Label on guard.

At the opposite end of the guard, loosen the wing screw holding the anti-kickback pawl assembly and lower the assembly until the tips of the pawls are  $\frac{1}{8}$ " below the top surface of the board to be cut. Retighten the wing screw securely.

**IN-RIPPING**—*In-rip* refers to a position when the blade is between the motor and the fence and parallel to the fence. (See figure 35.) To place the saw in this position, unlock the yoke, disengage the swivel latch pin and rotate the yoke 90° clockwise (viewing it from the carriage) until the swivel latch pin automatically indexes the yoke 90°. Relock the yoke. See "Adjustment of Pointers" to check accuracy of "In-Rip" scale reading. Position the motor on the radial arm until the pointer on the "In-Rip" scale indicates the desired width of the finished cut board. Tighten the carriage lock knob securely. Position the discharge elbow on the guard so that sawdust will be blown toward the rear of the saw. Turn the saw "On" and lower the radial arm until the saw blade cuts into the table top about  $\frac{1}{32}$ ". Turn the saw "Off". Now adjust the saw guard and anti-kick pawl assembly as described in the paragraph "Ripping". The board to be ripped must be fed into the saw blade from the right side of the table, therefore, the normal position for the operator is also at the right side of the table. With the left hand safely clear of the blade and holding the board to be ripped down against the table and against the face of the fence as a guide, use the right hand to feed the board into the saw. The left hand should remain stationary, serving as a guide only. As the right hand approaches the left hand, hold a push stick with the right hand to complete the cut. Do not leave a long board unsupported so that the spring of the board causes it to shift on the table. A support like that described in "Cross-Cutting" can be used to support the board behind the blade; and if the board is very long, use another support in front of the saw. Ripped boards up to  $8\frac{3}{8}$  inches wide can be cut in the "In-Rip" position when the fence is against the front table. With the fence moved to the extreme rear position, ripped boards up to 16 inches wide can be cut.

**OUT-RIPPING**—*Out-rip* refers to a position when the motor is between the blade and the fence. Normally, this position is only used when the width of the required ripped board cannot be cut from the in-rip position. Ripped boards up to  $18\frac{1}{4}$ " wide can be cut in the out-rip position when the fence is against the front table. With the fence moved to the extreme rear position, ripped boards up to  $25\frac{3}{8}$  inches

## ROUTING AND DOVETAILING

Routing and dovetailing are done with the motor indexed and locked 90° from the horizontal except that this time the externally threaded stub end opposite the normal blade end is between the motor and the table top. The following chucks will mate with this external 1/2-20 thread. (See figure 40.)

0" to 1/4" Key Chuck  
5/64" to 1/2" Key Chuck

The following routers and dovetails are recommended:

1/8" router	5/8" router
1/4" router	3/8" dovetail
3/8" router	1/2" dovetail
1/2" router	

Routing may be done by either moving the work with a stationary router or by clamping the work to the table and moving the router. Always approach the router bit from the left hand side of the saw.

## BORING

Your saw can also be converted to a horizontal drill for boring by using one of the recommended chucks and the proper drill. For drilling holes on an angle the radial arm should be positioned to the desired angle while the work is parallel to the fence. (See figure 41.)

## SANDING

Using the 10" sanding disc mounted on the saw end of the motor, you can convert your saw into a sander which can be operated in any position. The loose collars should be used on both sides of the sanding disc.

## FENCE LOCATIONS

There are three positions in which the fence can be located. (See figure 42)

1. Normal position.
2. Position used for maximum cross-cut on 1" material and for greater bevel and miter capacity.

**CAUTION:** Rip scales cannot be used in this position.

3. Position used for maximum out-rip capacity.

## STABILIZING WASHERS FOR THIN BLADES

Stabilizing washers should be used with blades for improved appearance of the finish cuts.

## BRAKE

The motor of this saw is equipped with a built-in electro-mechanical brake to eliminate a long coast time after the saw is turned off. When the motor is started, the brake shoe is instantly pulled away from the brake lining so that the motor does not start under load. When the motor is turned off the braking action takes place automatically. This brake is designed to stop a free running saw blade in 5 to 10 seconds. **DO NOT** attempt to alter either the brake disc or the lining to get a faster stopping time. Stopping the blade too suddenly could possibly unscrew the shaft nut.

## HELPFUL HINTS

1. The life of the laminated saw table can be greatly lengthened if a 1/4" piece of plywood is tacked to the table top after leveling. Then all cutting can be done in the added piece of plywood instead of the laminated table.
2. When sanding the table top or routing with the work stationary, the arm lock pin can be prevented from automatically indexing at 0° and 45° by loosening the arm latch handle to provide free movement of arm. (See figure 43.)

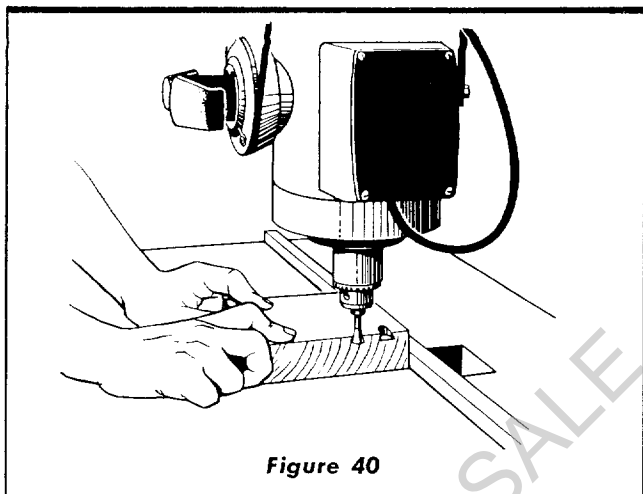

Figure 40

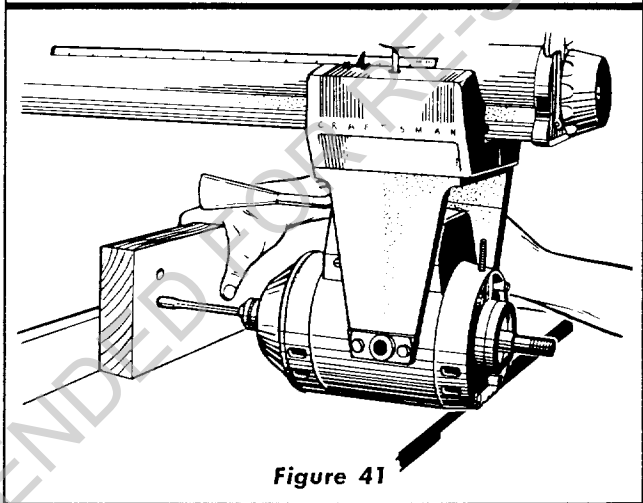

Figure 41

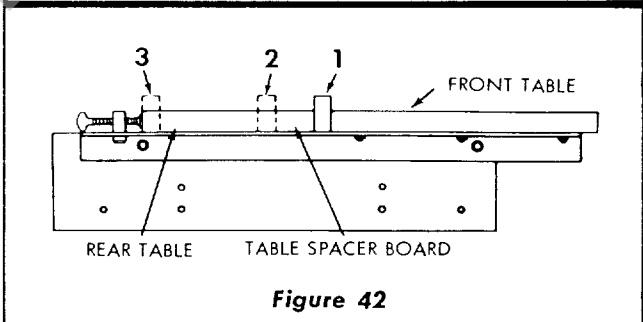

Figure 42

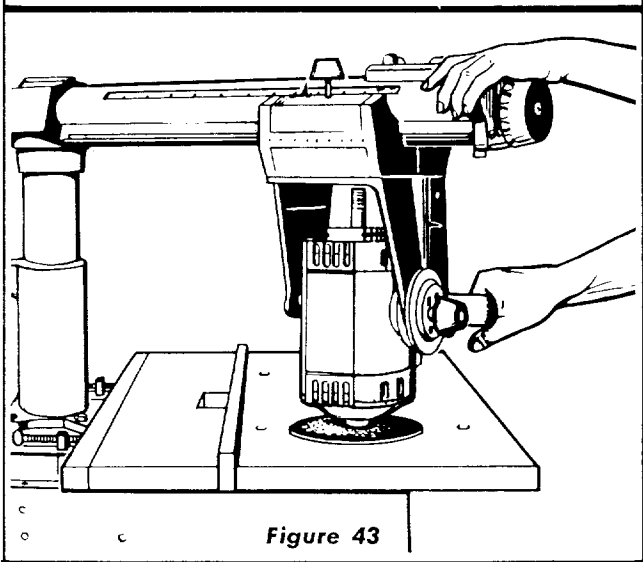

Figure 43

## TROUBLE SHOOTING CHART

TROUBLE	PROBABLE CAUSE	REMEDY
Blade "heels" to right or left.	1. Heel has not been taken out of blade.	1. Refer to "STEP SIX — CHECKING THE SAW BLADE FOR HEEL (Left and Right)."
Cannot "rip" properly, wood smokes and motor stops.	1. Dull blade. 2. Crosscut travel and rip fence are not squared. 3. Radial arm not locked in 0° position. 4. Blade not squared to the table top.	1. Check for sharpness of blade or warped board. Refer to the paragraph entitled "RIPPING." Ripping with hollow-ground blades when boards are badly warped is very difficult. 2. Refer to "STEP THREE — SQUARING THE CROSS-CUT TRAVEL." 3. Make sure the radial arm is locked and indexed properly in the 0° position. 4. Refer to "STEP FIVE — SQUARING THE SAW BLADE TO THE TABLE TOP."
Elevation crank operates roughly; chatter exists.	Column tube key not adjusted properly.	Check adjustment of key plug. Refer to "STEP TWO — CHECKING FOR LOOSENESS OF COLUMN TUBE IN COLUMN SUPPORT."
Motor will not run.	1. Protector open; circuit broken. 2. Low voltage.	1. Reset protector by pushing in on red button, located on top of motor junction box (indicated by audible click). 2. Check power line for proper voltage.
Motor will not run and fuses "BLOW."	1. Short circuit in line cord or plug. 2. Short circuit in motor terminal box or loose connections.	1. Inspect line cord and plug for damaged insulation and shorted wires. 2. Inspect all terminals in motor terminal box for loose or shorted terminals.
Blade does not maintain constant depth of cut across table.	1. Plane of table top not parallel to horizontal plane through radial arm. 2. Table badly warped.	1. Table is not aligned with radial arm. Refer to "STEP FOUR — ADJUSTING THE TABLE PARALLEL TO RADIAL ARM." 2. Replace table top.
Blade does not cut squarely, or repeat cuts cannot be secured.	1. Excessive free play in column tube key adjustment. 2. Excessive free play in radial arm. 3. Crosscut travel and rip fence are not squared. 4. Improper movement of arm for miter cuts.  5. Saw blade not square to the table top. 6. Bearings loose on track. 7. Yoke does not index properly.  8. Yoke clamp does not tighten yoke; or looseness is felt in yoke assembly.	1. Refer to "STEP TWO — CHECKING FOR LOOSENESS OF COLUMN TUBE IN COLUMN SUPPORT." 2. Remove radial arm cap and check the two 3/8-inch bolts for tightness. 3. Refer to "STEP THREE — SQUARING THE CROSS-CUT TRAVEL." 4. Before moving the radial arm to the desired miter index position, mainly 0° and 45° positions, make sure the arm latch handle is rotated just 1/4th. It may be advisable to push on the arm latch lever solidly with the palm of the hand to insure proper indexing at 0° and 45° positions. Refer to the paragraph entitled "ANGULAR MOVEMENT AND LOCKING OF THE RADIAL ARM." 5. Refer to "STEP FIVE — SQUARING THE SAW BLADE TO THE TABLE TOP." 6. Refer to paragraph entitled "CARRIAGE ADJUSTMENT," under "ADJUSTMENTS TO COMPENSATE FOR WEAR." 7. Check to see that yoke does index properly and/or swivel latch pin moves irregularly. If bolts on swivel latch pin housing are loose, tighten them after observing "STEP SIX — CHECKING THE SAW BLADE FOR HEEL." 8. Refer to paragraph entitled "YOKE CLAMP HANDLE ADJUSTMENT" under "ADJUSTMENTS TO COMPENSATE FOR WEAR."

### TROUBLE SHOOTING CHART—MOTOR (See Page 23)

## CRAFTSMAN ACCRA-ARM, 10-INCH RADIAL SAW, MODEL No. 113.29410

All parts illustrated in Figures 47 through 50 and listed under part numbers may be ordered through any Sears retail store or catalog order house. Order parts by mail from the catalog order house which serves the territory in which you live. In several instances, part numbers are listed for COMPLETE ASSEMBLIES. All parts are shipped prepaid within the limits of the continental United States.

WHEN ORDERING REPAIR PARTS, ALWAYS GIVE THE FOLLOWING INFORMATION AS SHOWN ON THIS LIST:

1. THE PART NUMBER
2. THE PART NAME
3. THE MODEL NUMBER 113.29410.
4. THE NAME OF ITEM—RADIAL SAW.

Always order by Part Number — not by Key Number

### FIGURE 47 PARTS LIST

Key No.	Part No.	Description	Key No.	Part No.	Description
1	30473	Plate Assembly Cover	31	453151	Pin, Groove, 3/16 x 1-3/4, Type E
2	448033	Screw, No. 10-32 x 3/8, Type 23C1, Pan Hd. Slotted, Cad. Pl. Steel	32	448039	Screw, No. 10-32 x 3/4, Type 23C1, Pan Hd. Slotted, Cad. Pl. Steel
3	37418	Cap, Radial Arm	33	60076	Washer, Plain, .505 x 1-1/8 x 1/16, Steel
4	115109	*Washer, Lock, Med., 1/4 S.A.E., Steel	34	37372	Lever, Arm Latch
5	191230	*Screw, Mach., 1/4 x 28 x 1, Fil. Hd. Slotted, Cad. Pl. Steel	35	37373	Washer, Spring
6	448001	Screw, No. 6-32 x 1/4, Type 23C1, Pan Hd. Slotted, Cad. Pl. Steel	36	60030	Washer, Plain, .505 x 1 x 1/32, Steel
7	37935	Washer, Fiber, .140 x .250 x 1/32	37	37374	Handle
10	145205	*Screw, Sheet Metal, No. 8 x 3/4, Type B, Pan Hd., Cad. Pl. Steel	38	60077	Screw, Mach., 1/4-20 x 1-3/8, Truss Hd. with Lockwasher, Steel
11	37863	Arm, Radial	39	30493	Nut, Wing
12	37867	Trim, Radial Arm	40	37938	Washer, Plain, 11/32 x 7/8 x 1/16, Cad. Pl. Steel
13	134530	*Nut, Hex., No. 6-32 x 5/16 x 7/64, Cad. Pl. Steel	41	37875	Relief, Strain
14	138473	*Washer, Lock, No. 6, External Tooth, Steel	42	30496	Wrench, Shaft
15	37873	Plate Safety Lock	43	30494	Collar
16	37876	Bolt, Safety Lock	44	60170	†Blade, Saw, 10" Free-Cut Combination
17	37878	Cover, Switch	45	30495	Nut, Shaft
18	37861	Key, Safety Lock	46	3540	Wrench, Arbor
19	133427	*Screw, Mach., No. 6-32 x 7/16, Flat Hd. Slotted, Cad. Pl. Steel	50	30671	Tube Assembly, Column
20	448017	*Screw, No. 8-32 x 3/4, Type 23C1, Pan Hd. Slotted, Cad. Pl. Steel	51	30469	Plug, Adapter
21	37874	Switch	52	37363	Cord and Plug
22	30490	Spring, Arm Latch	53	115543	*Washer, Lock, No. 6, Internal Tooth, Steel
23	30489	Washer, Spring Support	54	30472	Clamp, Cord
24	30655	Ring, Retaining	55	37871	Clip, Retaining
25	37370	Shaft Assembly, Latch Arm	56	448011	Screw, No. 8-32 x 3/8, Type 23C1, Pan Hd. Slotted, Cad. Pl. Steel
26	30482	Pin, Arm Lock	57	9415837	*Screw, Mach., 3/8-16 x 3/4, Hex. Hd., Cad. Pl. Steel
27	30662	Screw, Arm Lock	58	115548	*Washer, Lock, 3/8, Internal Tooth, Stl.
28	120214	*Washer, Lock, Med., 5/16 S.A.E., Steel	59	30479	Latch, Arm
29	9421621	*Screw, 5/16-18 x 5/8, Socket Hd. Cap, Steel	60	30661	Shoe, Brake
30	37866	Cap, Trim	61	37435	*Wrench, Hex. "L", 1/4" Across Flats
			62	30474	Indicator No. 1
			Not Shown	63157	Operating Instructions and Parts List for Craftsman Accra-Arm 10" Radial Arm Saw Model 113.29410

\* Standard Hardware Item — May be Purchased Locally.

† Stock Item — may be secured through the Hardware Department of most Sears or Simpsons-Sears Retail Stores or Catalog Order Houses.

NOTE: Shipping and handling charges for standard hardware items (identified by\*) such as nuts, screws, washers, etc. make buying these items by mail uneconomical. To avoid shipping and handling charges, you may obtain most of these locally.



**CRAFTSMAN ACCRA-ARM, 10-INCH RADIAL SAW, MODEL No. 113.29410**

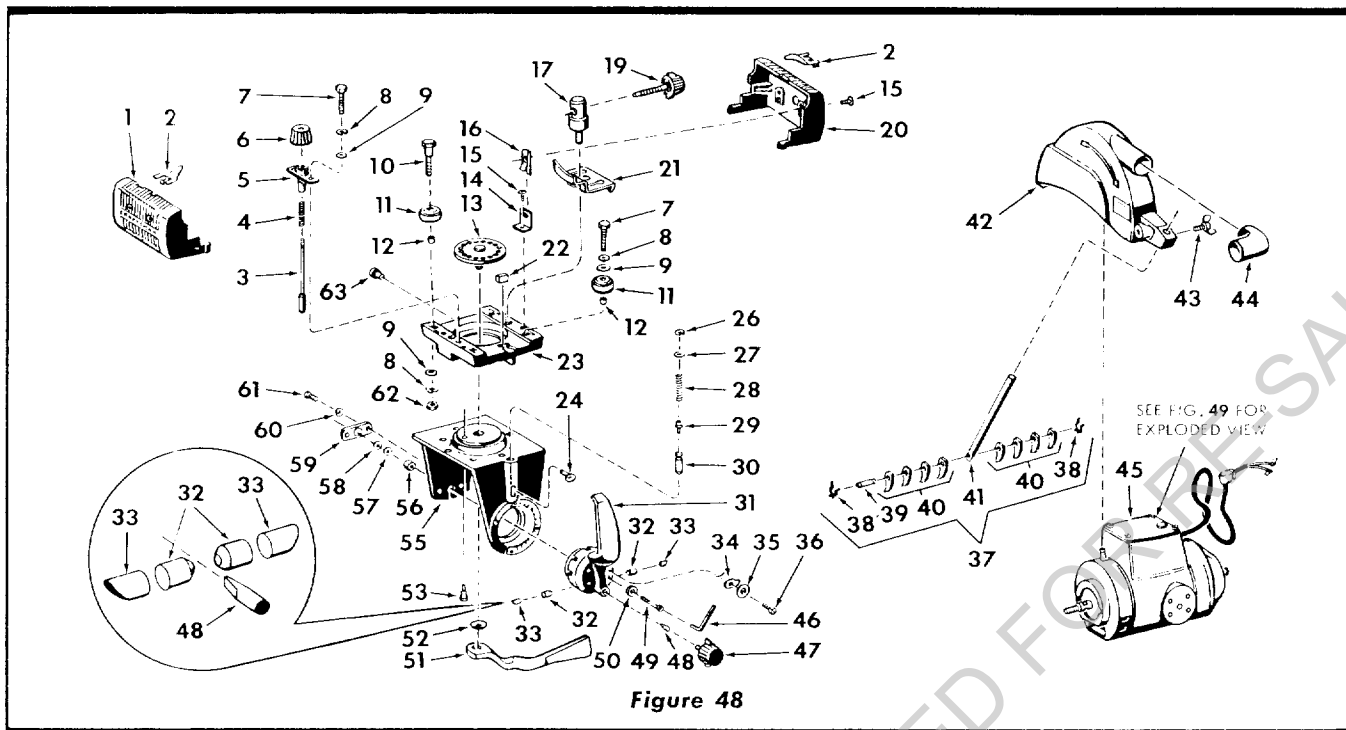

**Figure 48**

**FIGURE 48 PARTS LIST**

Key No.	Part No.	Description
1	37864	Cover, Carriage, Left Hand
2	30683	Indicator, Rip Scale
3	37494	Pin, Swivel Latch
4	30521	Spring, Swivel Latch
5	37385	Housing, Latch Pin
6	30519	Handle, Swivel Latch Pin
7	9415815	*Screw, Mach., 5/16-18 x 1, Hex. Hd. Indented, Cad. Pl. Steel
8	120214	*Washer, Lock, Med., 5/16 S.A.E., Steel
9	37936	Washer, Plain, .328 x 3/4 x 1/16, Steel
10	37387	Screw, Eccentric
11	37386	Bearing, Ball
12	37388	Sleeve, Bearing
13	30566	Clamp Assembly, Yoke
14	37392	Bracket, Carriage Cover Mounting
15	9404365	Screw, No. 8-32 x 5/16, Type 23C1, Pan Hd. Slotted, Cad. Pl. Steel
16	37393	U-Nut
17	37389	Pin, Lock Screw
19	37391	Knob Assembly, Carriage Lock
20	37865	Cover, Carriage, Right Hand
21	37870	Shoe, Rip Lock
22	30567	Bumper, No. 2
23	37396	Carriage
24	30693	Handle, Latch Pin
26	30546	Ring, Retaining, No. 2
27	30547	Disc
28	30548	Spring, Latch Pin
29	30690	Retainer, Latch Pin Handle
30	30689	Pin, Bevel Latch
31	30556	Handle, Bevel Index
32	30663	Expander
33	30665	Shoe, Index Handle Brake

Key No.	Part No.	Description
34	30559	Indicator, No. 2
35	37935	Washer, Fibre, .140 x .250 x 1/32
36	448001	Screw, No. 6-32 x 1/4, Type 23C1, Pan Hd. Slotted, Cad. Pl. Steel
37	37398	Pawl Assembly, Anti-Kickback
38	30542	Washer "X"
39	37400	Pin, Cross
40	30543	Pawl, Anti-Kickback
41	37399	Rod
42	37397	Guard
43	30540	Screw, Wing
44	37429	Elbow, Discharge
45	37881	Motor Assembly (Less Guard Stud) (See Fig. 49 for Exploded View)
46	37435	*Wrench, Hex. "L", 1/4 Across Flats
47	30551	Knob Assembly, Bevel Lock
48	30664	Pad, Pressure
49	9421626	*Screw, 5/16-18 x 1-1/2, Hex. Socket Hd. Cap, Plain
50	30606	Washer, Index Handle
51	37403	Handle, Yoke Clamp
52	37816	*Washer, .630 x 1-1/8 x 3/32, Steel
53	30558	Screw, Lock
55	37426	Yoke Assembly
56	37402	Bushing, Motor Support
57	30509	Washer, End Play, No. 8
58	30604	Washer, Oil Sling
59	37401	Plate, Motor Support Bushing
60	115109	*Washer, Lock, Med., 1/4 S.A.E., Steel
61	60021	*Screw, Mach., 1/4-20 x 7/16, Hex. Hd., Steel
62	124824	*Nut, Hex., 5/16-18 x 1/2 x 3/16, Steel
63	30565	Bumper

\* Standard Hardware Item — May be Purchased Locally.

**CRAFTSMAN ACCRA-ARM, 10-INCH RADIAL SAW, MODEL No. 113.29410**

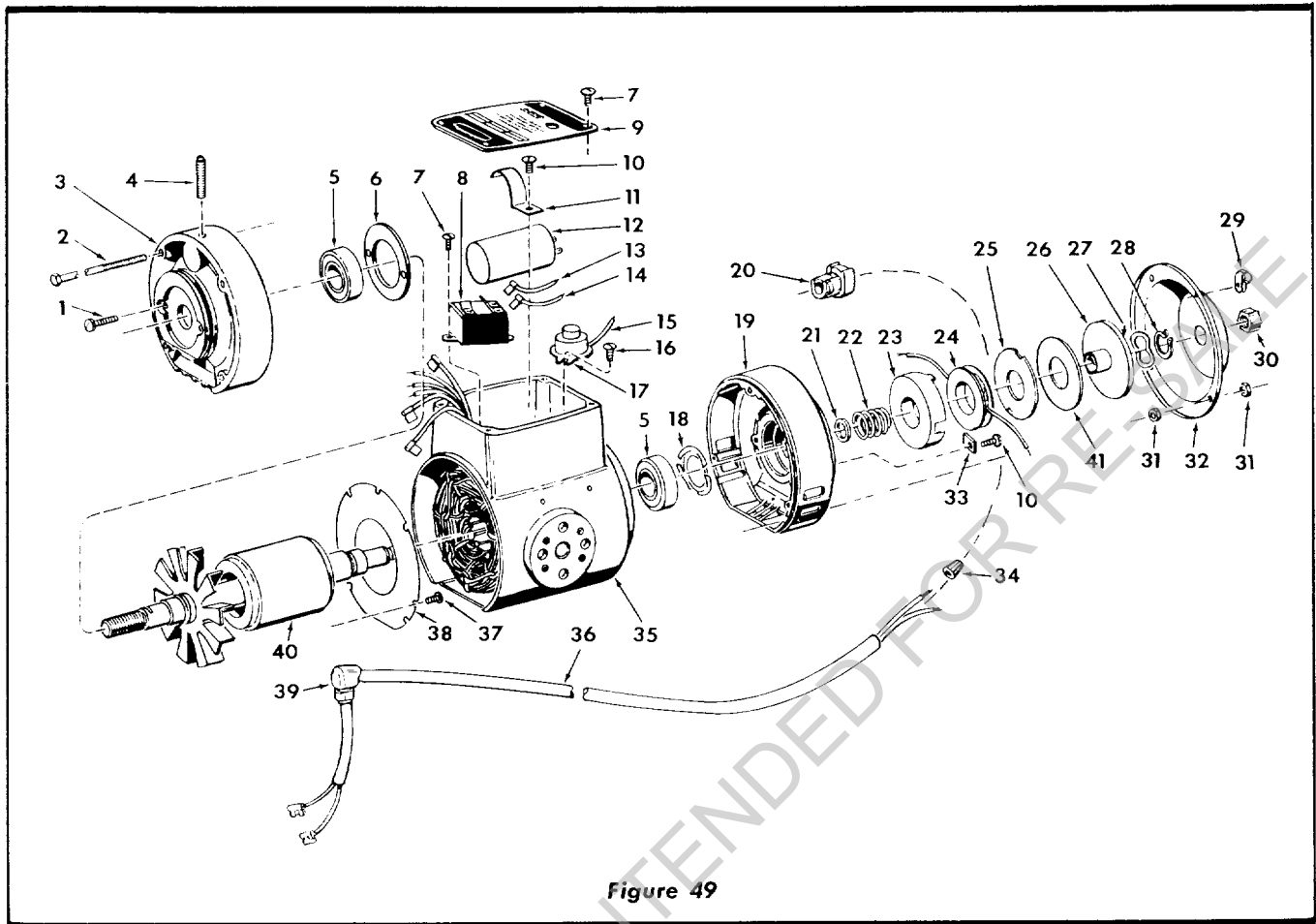

**Figure 49**

**FIGURE 49 PARTS LIST**

Key No.	Part No.	Description
1	455330	*Screw, Mach., No. 10-32 x 1, Pan Hd. Slotted with Lockwasher, Cad. Pl. Steel
2	30697	Screw, Stator, No. 2
3	37427	Shield, End (Fan Blade End)
4	30570	Stud, Guard
5	30571	Bearing
6	30572	Plate, Bearing Retainer
7	9404351	Screw, No. 6-32 x 5/16, Type 23C1, Pan Hd. Slotted, Cad. Pl. Steel
8	30588	Relay
9	37882	Plate, Identification
10	448011	Screw, No. 8-32 x 3/8, Type 23C1, Pan Hd. Slotted, Cad. Pl. Steel
11	30700	Clamp, Capacitor
12	30586	Capacitor
13	37409	Lead Assembly, No. 1
14	37410	Lead Assembly, No. 2
15	30619	Wire, No. 16, 3-1/2", AWG U.L. Approved
16	9404353	*Screw, No. 6-32 x 7/16, Type 23C1, Pan Hd. Slotted, Cad. Pl. Steel
17	37408	Protector
18	30580	Washer, Spring

Key No.	Part No.	Description
19	37407	Shield, End (Opposite Fan Blade End)
20	37818	Relief, Strain
21	37942	Washer, Spacer
22	37415	Spring
23	37908	Housing, Brake Coil
24	37883	Coil, Brake
25	63134	Shoe, Brake
26	37884	Disc, Brake
27	37886	Washer, Spring
28	30783	Ring, Retaining
29	30613	Clamp, No. 2, Cord
30	30582	Cap, Shaft
31	120622	*Nut, Hex., No. 8-32 x 11/32 x 1/8, Cad. Pl. Steel
32	37434	Cover, Brake
33	37412	Cleat
34	30573	Connector, Wire
35	37912	Stator Assembly
36	37877	Cord
37	448001	Screw, No. 6-32 x 1/4, Type 23C1, Pan Hd. Slotted, Cad. Pl. Steel
39	37875	Relief, Strain
38	30577	Plate, Baffle
40	37885	Rotor Assembly
41	63137	Lining, Brake

\* Standard Hardware Item — May be Purchased Locally.

**CRAFTSMAN ACCRA-ARM, 10-INCH RADIAL SAW, MODEL No. 113.29410**

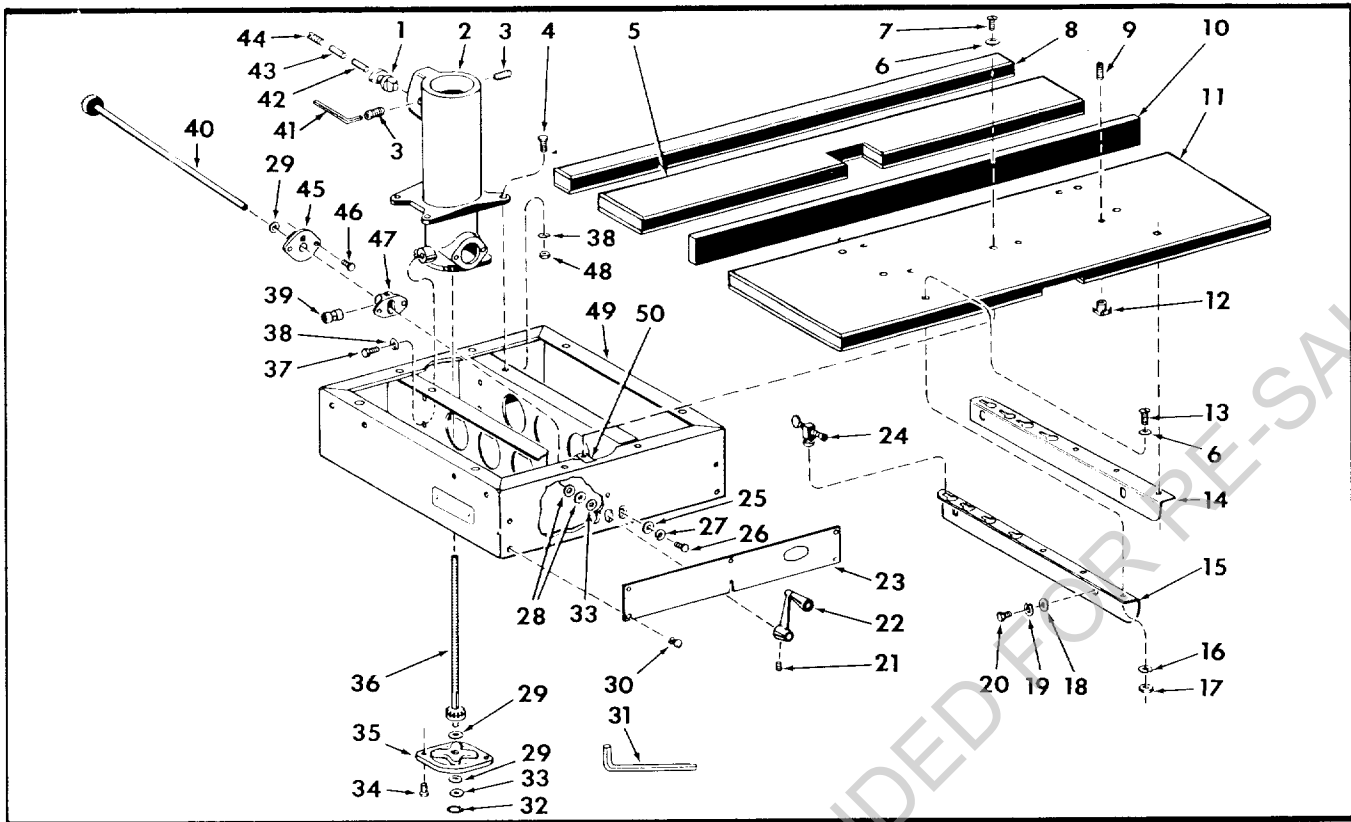

**FIGURE 50 PARTS LIST**

Key No.	Part No.	Description
1	63079	Key, Column Tube
2	37868	Support, Column
3	139416	Screw, Set, 3/8-16 x 5/8, Socket Hd., Cone Pt.
4	60020	*Screw, Mach., 3/8-16 x 1-1/8, Hex. Hd. Slotted, Steel
5	37379	Table, Rear
6	37937	Washer, 17/64 x 5/8 x 1/32, Cad. Pl. Steel
7	60057	*Screw, Mach., 1/4-20 x 1-1/4, Pan Hd. Slotted
8	37378	Board, Table Spacer
9	102707	*Screw, Set, 1/4-20 x 1/2, Slotted
10	37377	Fence
11	37376	Table, Front
12	37384	T-Nut
13	60056	Screw, Mach., 1/4-20 x 1, Pan Hd. Slotted
14	37880	Channel, Table Mtg., Right Hand
15	37879	Channel, Table Mtg., Left Hand
16	115109	*Washer, Lock, Med., 1/4 S.A.E., Steel
17	115120	*Nut, Hex., 1/4-20 x 7/16 x 3/16, Stl.
18	60013	*Washer, 11/32 x 7/8 x 1/16, Steel
19	120214	*Washer, Lock, Med., 5/16 S.A.E., Stl.
20	60078	*Screw, Mach., 5/16-18 x 1/2, Hex. Hd., Steel
21	102570	*Screw, Set, 1/4-20 x 3/8, Socket Hd., Cad. Pl. Steel
22	30518	Crank Assembly, Elevation
23	30517	Plate, Identification
24	37862	Clamp, Table
25	60079	*Washer, 13/64 x 7/16 x 1/16, Cad. Pl. Steel

Key No.	Part No.	Description
26	178451	*Screw, Mach., No. 10-32 x 3/8, Hex. Hd., Cad. Pl. Steel
27	120217	Washer, Lock, Med., No. 10 S.A.E., Stl.
28	30604	Washer, Oil Sling
29	30509	Washer, Flat, (End Play) (as required)
30	30675	Fastener, Stud
31	30505	Wrench, Hex "L", 1/8 Across Flats
32	30516	Ring, Retaining
33	60080	Washer, Plain, .515 x 7/8 x 1/32, Stl.
34	423561	*Screw, Mach., 5/16-18 x 7/8, Hex. Hd., Cad. Pl. Steel
35	37428	Plate, Retaining
36	30678	Shaft Assembly, Elevation
37	60022	*Screw, Mach., 3/8-16 x 5/8, Hex. Hd., Steel
38	115093	Washer, Lock, Med., 3/8 S.A.E., Steel
39	30511	Pin, Pivot
40	30508	Shaft Assembly, Elevation Crank
41	37911	Wrench, Hex "L", 3/16 Across Flats
42	63077	Plug, Friction (Nylon)
43	63078	Plug, Back-up (Steel)
44	102718	Screw, Set, 5/16-18 x 1/2, Slotted, Cup Pt.
45	30510	Bracket, Elevation Shaft Bearing
46	448649	*Screw, 1/4-20 x 3/4, Type 23C1, Hex. Hd., Cad. Pl. Steel
47	30512	Bracket, Bearing
48	118615	*Nut, Hex., 3/8-16 x 9/16 x 21/64, Steel
49	37383	Base Assembly
50	37530	Nut, "U" Clip, 1/4-20

\* Standard Hardware Item — May be Purchased Locally.

# TROUBLE SHOOTING CHART—MOTOR

**NOTE:** Motors used on wood-working tools are particularly susceptible to the accumulation of sawdust and wood chips and should be blown out or "vacuumed" frequently to prevent interference with normal motor ventilation.

TROUBLE	PROBABLE CAUSE	REMEDY
Motor will not run.	<ol style="list-style-type: none"> <li>1. Protector open; circuit broken.</li> <li>2. Low voltage.</li> </ol>	<ol style="list-style-type: none"> <li>1. Reset protector by pushing in on red button, located on top of motor junction box (indicated by audible click).</li> <li>2. Check power line for proper voltage.</li> </ol>
Motor will not run and fuses "BLOW."	<ol style="list-style-type: none"> <li>1. Short circuit in line cord or plug.</li> <li>2. Short circuit in motor terminal box or loose connections.</li> </ol>	<ol style="list-style-type: none"> <li>1. Inspect line cord and plug for damaged insulation and shorted wires.</li> <li>2. Inspect all terminals in motor terminal box for loose or shorted terminals.</li> </ol>
<b>Motor fails to develop full power.</b> (Power output of motor decreases rapidly with decrease in voltage at motor terminals.) For example: a reduction of 10% in voltage causes a reduction of 19% in maximum power output of which the motor is capable, while a reduction of 20% in voltage causes a reduction of 36% in maximum power output.	<ol style="list-style-type: none"> <li>1. Power line overloaded with lights, appliances and other motors.</li> <li>2. Undersize wires or circuit too long.</li> <li>3. General overloading of power company's facilities. (In many sections of the country, demand for electrical power exceeds the capacity of existing generating and distribution systems.)</li> <li>4. Incorrect fuses in power line.</li> </ol>	<ol style="list-style-type: none"> <li>1. Reduce line load.</li> <li>2. Increase wire sizes, or reduce length of wiring.</li> <li>3. Request a voltage check from the power company.</li> <li>4. Install correct fuses.</li> </ol>
Motor starts slowly or fails to come up to full speed.	<ol style="list-style-type: none"> <li>1. Low voltage — will not trip relay.</li> <li>2. Starting relay not operating.</li> </ol>	<ol style="list-style-type: none"> <li>1. Correct low voltage condition.</li> <li>2. Replace relay.</li> </ol>
Motor overheats.	<ol style="list-style-type: none"> <li>1. Motor overloaded.</li> <li>2. Improper cooling. (Air circulation restricted through motor due to sawdust, etc.)</li> </ol>	<ol style="list-style-type: none"> <li>1. Correct overload condition.</li> <li>2. Clean out sawdust to provide normal air circulation through motor.</li> </ol>
Starting relay in motor will not operate.	<ol style="list-style-type: none"> <li>1. Burned relay contacts (due to extended hold-in periods caused by low line voltage, etc.)</li> <li>2. Open relay coil.</li> <li>3. Loose or broken connections in motor terminal box.</li> </ol>	<ol style="list-style-type: none"> <li>1. Replace relay and check line voltage.</li> <li>2. Replace relay.</li> <li>3. Check and repair wiring.</li> </ol>
<b>Motor stalls</b> resulting in blown fuses or tripped circuit breakers).	<ol style="list-style-type: none"> <li>1. Starting relay not operating.</li> <li>2. Voltage too low to permit motor to reach operating speed.</li> <li>3. Fuses or circuit breakers do not have sufficient capacity.</li> </ol>	<ol style="list-style-type: none"> <li>1. Replace relay.</li> <li>2. Correct the low line voltage condition.</li> <li>3. Replace fuses or circuit breakers with proper capacity units.</li> </ol>
Frequent opening of fuses or circuit breakers.	<ol style="list-style-type: none"> <li>1. Motor overloaded.</li> <li>2. Fuses or circuit breakers do not have sufficient capacity.</li> <li>3. Starting relay not operating (motor does not reach normal speed.)</li> </ol>	<ol style="list-style-type: none"> <li>1. Reduce motor load.</li> <li>2. Replace fuses or circuit breakers.</li> <li>3. Replace relay.</li> </ol>

COPYRIGHTED - NOT INTENDED FOR RE-SALE